

AGILENT VACUUM PRODUCTS CATALOG



Agilent Technologies



Agilent Technologies is your vacuum resource: a one-stop, truly global vacuum supplier with complete solutions for **Academic Research, Instrumentation Manufacturers, Industrial Applications** and **Analytical Labs**.

Our objective is your success.

Equipped with highly developed technical skills and rich experience in the vacuum field, we incorporate your needs to develop unique products that are user friendly, easy to maintain, robust and durable, at a low cost of ownership to you.

We are committed to product and service quality, to respecting the environment, and to sustainable development. Our ISO 9001 and ISO 14001 certifications demonstrate that Agilent is a partner you can rely on.

Agilent knows vacuum. It has been our focus and core competence for more than 60 years during which we have introduced many key innovations, from the Ion Pump, ConFlat sealing technology, and High Speed Diffusion Pumps to ContraFlow Leak Detection, IDP-Series Dry Scroll Pumps and TwisTorr turbomolecular pumps.

We seek the best solutions for your vacuum needs, and are pleased to offer you this catalog of more than 7,000 products that we stand behind with pride.



Powerful, precise, and easy to use, Agilent leak detectors are ideal for vacuum maintenance and diagnostics whether at first installation or during periodic inspections.



We continue to offer a wide range of vacuum valves, hardware, and measurement equipment to work with primary, high vacuum and ultra-high vacuum pumps in your application.



CONTENTS

Introduction



Turbo Pumps



Rotary Vane Pumps

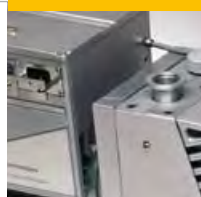

Turbo Pumping Systems

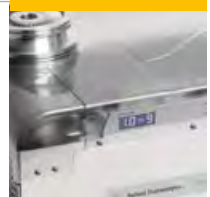

Rough Vacuum Pumps

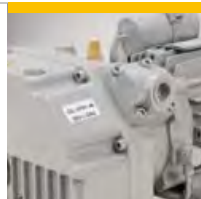

Leak Detection

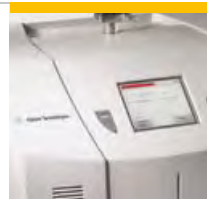

High Capacity
Rotary Vane Pumps and
Roots Pumping Systems



Vacuum Measurement



Dry Scroll Pumps



Vacuum Valves



Diffusion Pumps



Vacuum Components



Ion Pumps

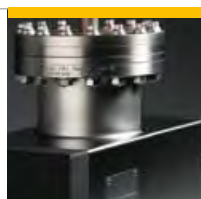

Training



AGILENT VACUUM MILESTONES

Agilent Vacuum: Technology Leadership

Agilent Vacuum Products Division, formerly Varian Vacuum, has always been in the forefront of vacuum technology, setting industry standards beginning with the invention of the ion pump that made UHV possible, through major developments in diffusion pump and leak detection technology and innovations in turbomolecular and dry scroll pumping, up to the most recent revolutionary TwisTorr FS turbo pump and IDP-15 dry scroll pump.

As Agilent/Varian is a pioneer in vacuum technology, many of our inventions, like the first ion pump created by Varian in the late '50s, have become standards in this industry. We continue to study and develop new solutions, partnering with our Customers and with the major Research Centers worldwide.

1930s

Varian brothers with physicist Bill Hansen create a prototype of the klystron, a radio vacuum tube central to radar technology.



1930

1957-59

Varian Associates invents the first Ion pump. The Vacuum Division becomes a separate business.



1940

1966-67

A new Vacuum factory opens in Torino, Italy.



1983

The StarCell Ion Pump is developed, and the Ion Pump worldwide Center is established in Torino.



1950

1992

The revolutionary new portable Helitest Leak Detector is introduced, with numerous applications in non-vacuum industries.



1960

1998

The TriScroll Dry Pumps are the only two stage scroll pumps on the market.



1970

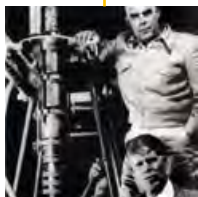

1948

On April 20 Sigurd and Russell Varian with Bill Hansen establish Varian Associates, Inc.



1961-65

ConFlat Flanges set the industry standard. Significant innovation in Diffusion pump technology markedly increases performance.

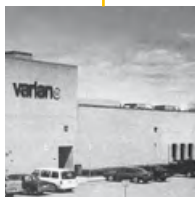

1971-1972

Acquisition of NRC plant in Lexington, MA. The Contra-Flow concept revolutionizes leak detection.



1986-90

Varian introduces Turbomolecular Pumps in collaboration with the Elettrorava company.



1992-94

The innovative MacroTorr concept allows much higher (x100) foreline pressures in Turbo pumps. ISO 9001 Certification is completed.



2001

Varian expands Torino facility with a third building, and completely renews the entire manufacturing site.

2002-2004

New Turbo-V Navigator series, with electronics on-board, followed by the Turbo-V K-G series with integrated electronics embedded in the pump body. First "smart" Rotary Vane Pumps employ an innovative frequency inverter.



2007-2008

The IDP-3 is the first 60 l/m scroll pump in the market. A new logistic warehouse completed the renovation of Torino plant.



2009-2010

Innovative line of TPS Turbo Pumping Systems. New High Capacity MS Rotary Vane Pumps and RPS Roots Pumping Systems, for demanding industrial vacuum applications.



2010

Varian becomes a part of Agilent Technologies, a global technology leader in chemical analysis, life sciences, diagnostics and applied markets.



2012

With the acquisition of PVR, Agilent Vacuum expands its offer for industrial rough vacuum applications. The plant in Valmadrera, Italy becomes the manufacturing site of Agilent Large RVP and Rough Vacuum Pumps.



2013

The breakthrough TwisTorr 304 FS with Floating Suspension marks another milestone in Agilent's history of innovation in Vacuum.



1980

1990

2000

2010

2005-2006

ISO 14001 Certification achieved. New VS Series leak detectors, and PHD-4 Portable Helium Detector.



2008

New TriScroll with Inverter technology. New XGS-600 Gauge Controller.



2010

The New Molecular-Drag Technology: TwisTorr Turbo Pumps offer unmatched vacuum performance in terms of pumping speed, compression ratio, compact size.

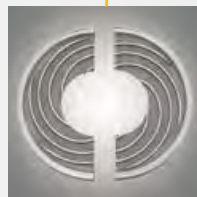

2011

The new 4-UHV is the first true 4-channel Ion Pump Controller for Ultra High Vacuum.



2013

Agilent introduces the state-of-the-art IDP-15 dry Scroll Pump, the quietest on the market.



2014

Vacuum and Leak Detection manufacturing starts in the Agilent facility in Penang, Malaysia.



VACUUM APPLICATIONS

Agilent Technologies thrives on supporting its customers in a variety of applications in many technological fields or disciplines. These include, but are not limited to:

Industrial Vacuum and Leak Detection Solutions

- Petrochemical
- Pharmaceutical
- Vacuum heat treatment
- Automotive
- Energy

Thin Film Deposition and Semiconductor Vacuum

- Surface coating
- Magnetic data storage
- Silicon semiconductor
- Compound semiconductor

Typical operating pressure (mbar)

> 1

> 10^{-2}

10^{-2} – 10^{-6}

1 – 10^{-8}

10^{-3} – 10^{-8}

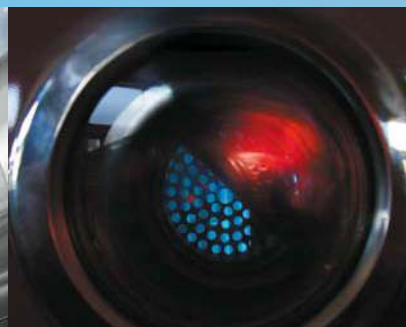

Instrumentation Manufacturers

- Mass spectrometers
- Electron microscopes
- Surface analysis
- Medical accelerators

Academia, Government and Labs

- Universities
- Scientific research laboratories
- Particle Accelerators and Synchrotrons
- Analytical Labs
- Space simulation

$1 - 10^{-8}$

$10^{-6} - 10^{-10}$

$10^{-2} - 10^{-11}$



AGILENT WORLDWIDE SALES AND SERVICE NETWORK

- Manufacturing Locations
- Agilent Offices
- ▲ Agilent Partners
- Service Hubs

Americas

○ **Agilent Technologies Inc.**
121 Hartwell Avenue,
Lexington MA 02421, USA
Tel: +1 781 861 7200
Fax: +1 781 860 5437
Toll free: +1 800 882 7426
Email:
vpl-customerservice@agilent.com

Argentina

▲ **VEQ S.A.**
Marcelo Deferrari
Av. Belgrano 1720-2
piso Buenos Aires, Argentina
Tel: 54-11-4382-5558
Fax: 54-11-4382-5558

Brazil

■ **Agilent Technologies Brasil**
Avenida Marcos Penteado de
Ulhoa - Rodrigues, 939 - 6º andar
Castelo Branco Office Park - Torre
Jacarandá - Tamboré
Barueri, Sao Paulo CEP: 06460-040
Toll free: 0800 728 1405

▲ **Radchrom Analitica Ltda**
Carlos Marguti
Rua Divino Salvador no. 276
Nova Paulina Sao Paulo, Brazil
Tel: 55-19-3833-1300
Fax: 55-19-3833-1200

▲ **Datasonic Industria e Distribuicao
de Eletronicos Ltda**
Marcos Procopio
Rua Quintino Bocaiuva no. 339
Palmeira, Campina Grande Brazil
58.401-170
Tel: 55-83-3321-2244
Fax: 55-83-3321-2244

Canada

▲ **CCR Process Products**
200 Terence Matthews,
Kanata, ON K2M 2C6
Tel: 613.591.9700
Fax: 613.591.3111

Mexico

■ **Agilent Technologies**
Concepcion Beistegui No 109 - Col
Del Valle, C.P. 03100, Mexico, D.F.
Tel: 52 5 523 9465
Fax: 52 5 523 9472

▲ **Labelle Industrial Sales**
Wesley Maynard
460 Eagle Drive El Paso, TX 79912
Tel: 915.726.1338

Peru

▲ **Grupo Tecnologico del Peru, S.A.**
Cesar Chui
Avenida Paseo de La Republica
6184 Miraflores, Lima, Peru
Tel: 51-1-242-0111
Fax: 51-1-447-3756

Other Countries

○ **Agilent Technologies Inc.**
121 Hartwell Avenue,
Lexington MA 02421, USA
Tel: +1 781 861 7200
Fax: +1 781 860 5437
Toll free: +1 800 882 7426

Europe, Middle East, Africa, India

○ **Agilent Technologies Italia SpA**
Via F.lli Varian 54 -
10040 Leini (Torino), Italy
Tel: +39 011 9979 111
Fax: +39 011 9979 350
Toll free: 00 800 234 234 00
Email:
vpt-customerservice@agilent.com

Benelux

■ **Agilent Technologies Netherlands
BV**
Groenelaan 5, 1186 AA
Amstelveen - The Netherlands
Tel: +31 20 547 2000
Fax: +31 20 547 2093
Toll free: 00 800 234 234 00

▲ **A de Jong TH Agilent**
Toermalijnring 1000,
3316 LC Dordrecht
Tel: +31 78 6552000
Fax: +31 78 6552010

Web and e-Commerce: www.agilent.com/chem/vacuum
Special Offers and Product News: www.vacuum-choice.com



Agilent VPD, Torino, Italy.



Agilent VPD, Penang, Malaysia.



Agilent VPD, Lexington, MA.



Agilent VPD, Valmadrera (LC), Italy.

Czech Republic

- ▲ **LABTECH s.r.o.**
Polni 23/340 639 00 Brno
Tel: +420 511 192 923
Tel: +420 511 192 921

France

- **Agilent Technologies**
Parc Technopolis -
Z.A. de Courtaboeuf -
3, avenue du Canada -
CS 90263 - 91978 Les Ulis cedex,
France
Tel: +33 (0) 1 64 53 61 15
Fax: +33 (0) 1 64 53 50 01
Toll free: 00 800 234 234 00

Finland

- ▲ **Mecastep Oy**
Vesijärvenkatu 76, 15140 Lahti
Tel: +358 40 5044057
Fax: +358 50 7800 4562

Germany and Austria

- **Agilent Technologies**
Sales & Services GmbH & Co. KG
Lyoner Str. 20 -
60 528 Frankfurt am Main,
Germany
Tel: +49 69 6773 43 2230
Fax: +49 69 6773 43 2250

India

North & East Zone

- **Agilent Technologies India Pvt Ltd.**
105 116, 1st Floor,
Splendor Forum Plot No 3,
District Center, Jasola
New Delhi 110025
Tel: +91 11 46237100
Fax: +91 11 46237105
Toll Free: 18001801517

West Zone

- **Agilent Technologies India Pvt Ltd.**
G01, Prime Corporate Park,
230/231, Sahar Road,
Opp. Blue Dart Center, Andheri East,
Mumbai- 400099
Tel: +91 22 30648200
Fax: +91 22 30648250
Toll Free: 18001801517

South Zone

- **Agilent Technologies India Pvt Ltd.**
C-Block, RMZ Centennial Plot
Number- 8A, 8B, 8C, 8D,
Doddanakundi Industrial Area,
ITPL Road, Mahadevapura Post,
Bangalore- 560048
Tel: +91 80 40614000
Fax: +91 80 40148991
Toll Free: 18001801517

Israel

- ▲ **ISI Israel Scientific Instruments Ltd.**
32 Shacham St, Petah-Tikva 49170
Tel: +972 (54) 4888174
Fax: +972-3-9229750

Italy

- **Agilent Technologies**
Rough Vacuum Pumps
Via Santa Vecchia, 107 - 23868
Valmadrera (Lecco), Italy
Tel: +39 0341 488 919
Fax: +39 0341 580 335
- ▲ **ECOVIDE**
Via degli Olmetti, 18, 00060
Formello (RM)
Tel: +39 3357756627
Fax: +39 06 90400230

Kazakhstan

- ▲ **CCS Services Central Asia Ltd.**
MTC Business Center,
Shevchenko str. 165/72G, 050009
Almaty, Kazakhstan
Tel: +7 727 237 77 80
Fax: +7 727 237 77 81

Norway

- ▲ **Matriks AS**
Forskningsparken,
Gaustadalleen 21,
0349 Oslo, Norway
Tel: +47 22 95 85 95
Fax: +47 22 95 85 60

Oman, Qatar, Saudi Arabia and U.A.E.

- ▲ **Gulf Bio Analytical LLC**
Office No.902, Sapphire Tower,
Al Ittihad Road, Deira Dubai
Tel: +971 4 250 7300
Tel: +971 4 250 7400/7500

Poland

- ▲ **Uni-Export Instruments Polska**
Ludwika Kickiego 4a lok. 50
04-369 Warszawa, Poland
Tel: +48 (0) 22 626 87 86
Fax: +48 (0) 22 626 87 85

Romania

- ▲ **HISTERESIS SRL**
Str. G. Enescu, Bl. 251, Sc. B, Ap.
13 730208 VASLUI Romania
Tel: +40 335 407 797
Tel: +40 318 171 731

AGILENT WORLDWIDE SALES AND SERVICE NETWORK



Russia

- ▲ **CCS Service**
Ivana Franko str., bld. 48G/4,
121351 Moscow
Tel: +7-495-626-59-43
Tel: +7-495-564-80-52
- ▲ **TAKO Line Ltd.**
Bolshaya Semyonovskaya, 42
105094 Moscow
Tel: +7-495-225-75-50
Tel: +7-499-369-02-69
- ▲ **Millab Company**
Dmitrovskoe shosse, 100 bld.2,
Moscow, 127247, Russia
Tel: +7 495-933-71-47
Tel: +7 495-933-71-48

Spain

- ▲ **TeraTorr Technologies SL Vacuum Engineering & Gas Analysis**
C/Las Fábricas nº1, Local 42
28923 Alcorcón (Madrid)
Tel: +34 910 298 111

Sweden

- ▲ **Rowaco AB**
Westmangatan 49, SE-582 16
Linköping
Tel: +46 13 13 80 10
Fax: +46 13 31 13 35

Switzerland

- ▲ **Swiss Vacuum Technologies SA**
Avenue des Champs-Montants
16b CH-2074 Marin-Epagnier
Tel: +41 32 725 2020
Tel: +41 79 318 0410
Fax: +41 32 725 2030

Turkey

- ▲ **SEM Endüstri Cihazları**
Acıbadem Mahallesi. Çiçekli
Sokak. Çiçek Apartmanı. A Blok
No: 1A/14, Kadıköy, İstanbul
Tel: +90 216 325 78 36
Fax: +90 216 325 16 24

Ukraine

- ▲ **Novations LLC**
Office 813, Build. 23, Mariny
Raskovoy Str., 02002 Kiev
Tel: +38 (044) 223-93-00
Fax: +38 (044) 223-93-11

UK and Ireland

- **Agilent Technologies UK Ltd.**
6 Mead Road, Oxford Industrial
Park - Yarnton, Oxford OX5 1QU,
UK
Tel: +44 (0) 1865 291570
Fax: +44 (0) 1865 291571
Toll free: 00 800 234 234 00

Other Countries

- **Agilent Technologies Italia SpA**
Via F.lli Varian 54 -
10040 Leini (Torino), Italy
Tel: +39 011 9979 111
Fax: +39 011 9979 350
Toll free: 00 800 234 234 00

China & Taiwan

China

- Beijing Office
- **Agilent Technologies (China) Co. Ltd.**
No.3, Wang Jing Bei Lu,
Chao Yang District, Beijing,
100102, China
Tel: +86 (0)10 64397888
Fax: +86 (0)10 64392765
Toll free: 800 820 3278
- Shanghai Office
- **Agilent Technologies**
16F Shanghai Litong Plaza,
No.1350 North Si Chuan Road,
Hongkou District, Shanghai, China
200080, China
Tel: +86 (0)21 36127688
Fax: +86 (0)21 66285169
Toll free: 800 820 3278
- Guangzhou Office
- **Agilent Technologies**
Unit 08, 66/F, Citic Plaza,
233 Tian He Bei Rd Guangzhou,
510613, China
Tel: +86 (0)20 38113988
Fax: +86 (0)20 86695861
Toll free: 800 820 3278
- Shenzhen Office
- **Agilent Technologies**
3/F Dutyfree Business Bldg., No.6,
1st Fu Hua Road,
Futian CBD Shenzhen, 518048
Tel: +86(0)755 83079589
Fax: +86(0)755 82763182
Toll free: 800 820 3278

- ▲ **East Changing Technologies, Inc.**
4/F, Building C, No 6 Yard,
Longxiangzhiban Industrial Park,
Huilongguan, Changping District,
Beijing 102208
Tel: +86(0)10 51668833
Fax: +86(0)10 51090523

- ▲ **Chengdu Wankemu Technology Co. Ltd.**
Chenghua District City, JingHua
Road No. 19,
Chengdu Sichuan Province
Tel: +13340990582 +13730837118
Fax: +86(0)28 84509526

- ▲ **CEVS Vacuum Technologies Beijing Co., Ltd.**
910 Office Hongyu Building, No.7,
Xueyuan Road, Haidian District,
Beijing 100083
Tel: +86(0)10 51313670
Fax: +86(0)10 51313671

- ▲ **Shaanxi Xingyuan Technology Co., Ltd.**
Room 511209, Zhongtian
Int. Apartment,
No. 269 Taibai South Road, Xi'an
Tel: +86(0)29 88763776 ext 802
Fax: +86(0)29 88232289

- ▲ **South East Chemicals & Instruments Ltd.**
RM 1210 Chaiwan Industrial City
Phase 1, 60 Wing Tai Road,
Chai Wan, Hong Kong
Tel: +852 28026333
Fax: +852 28070542

- ▲ **Qingdao Hongsen Telecom Technology Co. Ltd.**
Room 306, Block A, Digital
Technology Centre, 63 Haier Road
Laoshan District, 266000 Qingdao
City, Shandong Province
Tel: +86(0)532 55576895
Fax: +86(0)532 55576692

Taiwan

- **Agilent Technologies Taiwan Ltd.**
No.20, Gaoshuang Rd., Pingzhen
City Taoyuan County 32450
Taiwan, R.O.C.
Tel: +886 3 4959204
- ▲ **Trigger Technology Inc.**
1F, 386 Jiashing Rd., Chupei,
30264 Hsinchu
Tel: +886-3-658-5508
Fax: +886-3-658-5528
- ▲ **Advanced Hivac Application Co., Ltd.**
No. 45-2, 11th Neighborhood,
Dapuding, Zhunan Township,
Miaoli County 35057
Tel: +886-37-620170
Fax: +886-37-620172

Japan

- **Agilent Technologies Japan, Ltd.**
9-1 Takakura-cho Hachioji-city,
Tokyo, Japan
Tel: +81 3 5232 1253
Fax: + 81 - 120-565-154
Toll free: +81 - 120-477-111
- ▲ **Ailin Vacuum CO., Ltd.**
Head office
81 Haruhi-Higashide, Kiyosu,
Aichi, 452-0961 Japan
Tel: +81-52-401-2061
Fax: +81-52-401-6960
Kanto Office
3393-1 Kurohama, Hasuda,
Saitama, 349-0101 Japan
Tel: +81-48-769-7011
Fax: +81-48-769-7483
- ▲ **Marubishi Corporation**
1-51-1 Asahi-cho, Atsugi,
Kanagawa, 243-0014 Japan
Tel: +81-046-226-1471
Fax: +81-046-227-4021
- ▲ **K-Science Inc.**
2-24-4 Umezono, Tsukuba,
Ibaraki, 305-0045 Japan
Tel: 029-856-6300
Fax: 029-856-6301
- ▲ **Pascal Co., Ltd.**
Ibaraki Office
2288-10, Godai, Naka-city
Ibaraki
Tel: +81-29-270-7891
Fax: +81-29-270-8510
- ▲ **Asahi Glass Plant Inc.**
16-98 Otada Sintate, Kurose-cho
HigashiHiroshima-city
Hiroshima
Tel: +81-823-69-4318
Fax: +81-823-69-4338
- ▲ **Asahi Seiki Co., Ltd.**
11-16 Nishimiyaura Ohmuta-city
Fukuoka
Tel: +81-944-51-4448
Fax: +81-944-52-9027
- ▲ **Navatec Co., Ltd.**
39-1 Komagatani Habikino-city
Osaka
Tel: +81-72-957-7107
Fax: +81-72-957-7102

South Asia, Pacific & Korea

Australia - New Zealand

- ▶ **Dynapumps (Victoria & New Zealand)**
Unit 16, 44 Mahoneys Rd.
Thomastown, Victoria 3047,
Australia
Tel: +61 03 9460 6633
Fax: +61 03 9469 5488
- ▶ **Dynapumps (New South Wales)**
Unit 5, 6 Stanton Rd.
Seven Hills, NSW 2147,
Australia
Tel: +61 02 9624 7888
Fax: +61 02 9624 7999
- ▶ **Dynapumps (Queensland)**
Unit 7, 14 Hopper Ave.
Ormeau QLD 4208,
Australia
Tel: +61 07 5546 7777
Fax: +61 07 55467100
- ▶ **Dynapumps (West. Australia)**
88 Belgravia Street, Belmont
Western Australia 6104,
Tel: +61 8 9424 2000
Fax: +61 8 9424 2001

Indonesia

- ▶ **PT Berca Niaga Medika, Jakarta**
Berca Building, Level 3,
Jalan Abdul Muis 62,
Jakarta 10160
Indonesia
Tel: +62 21 351 8826
- ▶ **PT Berca Niaga Medika, Surabaya**
Jalan Tegalsari 2 H,
Surabaya 60241, Indonesia
Tel: +62 31 567 4477
Tel: +62 31 567 4488

Korea

- ▶ **Agilent Technologies Korea Ltd.**
Shinsa 2nd Bldg. 1F,
966-5 Daechi-dong, Kangnam-gu,
Seoul, Korea 135-280
Tel: +82 (0)2 2194 9449
Fax: +82 (0)2 3452 3947
Toll free: 080 222 2452
- ▶ **Samho Syscom**
101-1512 Digital Empire 2,
486 Shin-Dong, Yeongtong-Gu,
Suwon City, Gyeonggi-Do
Tel: +82 (0)31 695 5561
Fax: +82 (0)31 695 5563
- ▶ **Teovac**
613 Hongin Tower, 536-9,
Bongmyung-Dong, Yusung-Cu,
Daejeon City
Tel: +82 (0)42 934 1859
Fax: +82 (0)42 489 1854
- ▶ **MKV Co. Ltd.**
107, Pohang Techno Park
Venture 1, 394, Gigok-Ro, Nam-Gu,
Pohang City
Tel: +82 (0)54 279 1364
Fax: +82 (0)54 279 1157
- ▶ **YNB Science**
2322 Hwamyung-Dong, Buk-Gu,
Busan City
Tel: +82 (0)51 553 6307
Fax: +82 (0)51 553 6308

Malaysia

- ▶ **Agilent Technologies LDA Sdn Bhd**
Bayan Lepas Free Industrial Zone
11900 Penang, Malaysia
Tel: +60 4 680 3888
Fax: +60 4 680 3708
Toll free: 1 800 880 805
- ▶ **Agilent Technologies Sales (M) Sdn Bhd**
Unit 201, Level 2, Uptown 2,
2 Jalan SS21/37,
Damansara Uptown
47400 Petaling Jaya,
Selangor, Malaysia
Tel: +60 3 7727 8808
H/P: +60 12 954 1088
Fax: +60 3 7727 1239
Toll free: 1 800 880 805
- ▶ **ELSO Technologies (M) Sdn Bhd**
No. 8E, 1st Floor, Jln Tun Dr. Awang,
Bukit Jambul, Bayan Lepas,
Penang 11900 Malaysia
Tel: +604 630 1166 / 67
H/P: +6016 422 8644
Fax: +604 630 1168

Singapore

- ▶ **Agilent Technologies Singapore Pte Ltd.**
No. 1 Yishun Avenue 7,
Singapore 768923
Tel: +65 6215 8045 / 8403
Fax: +65 6754 0574
Toll free: 1 800 2762622
- ▶ **Singapore Technologies Electronics Ltd.**
(Large-Scale Systems Group -
Marketing Division)
24 Ang Mo Kio Street 65,
Singapore 569061
Tel: +65 6413 1039
Fax: +65 6484 5357

Thailand

- ▶ **Next Generation Products Co., Ltd.**
89/61 Klang Mueng Village
(Phase 2) Soi Ladphrao 71,
Ladphrao, Bangkok 10230,
Thailand
Tel: +662 932 3488-9
Fax: +662 932 3490
H/P: +66-81-553-7794

Vietnam

- ▶ **Tramat Co Ltd, Hanoi**
12 Hang Duong Street, Hoan Kiem
District Hanoi, Vietnam
Tel: +84 4 3828 1631
Fax: +84 4 38251746
- ▶ **Tramat Co Ltd, Ho Chi Minh City**
6B Nguyen Canh Chang Street
Dist 1, Ho Chi Minh City, Vietnam
Tel: +84 8 3920 1452
Fax: +84 8 38364331

Other Countries

- ▶ **Agilent Technologies Singapore Pte Ltd.**
No. 1 Yishun Avenue 7,
Singapore 768923
Tel: +65 6215 8045 / 8403
Fax: +65 6754 0574
H/P: +60 12 954 1088
Toll free: 1 800 2762622
Email:
vps-customerservice@agilent.com



AGILENT CUSTOMER SUPPORT PROGRAMS

As a world-class company, we are committed to excellence in customer support as a means to enhance the value of our products for our customers and to lower total cost of ownership. Our support strategy is based on the following fundamentals:



Telephone Hotlines

Our toll free hotlines provide you with the easiest live front-end support. Our native language customer service and technical support representatives will assist you with order information, backlog management, return authorization, pricing and delivery, and with product technical data, literature fulfillment and troubleshooting.



Vacuum Training Programs

Agilent's highly regarded training program is staffed by dedicated professionals with expertise and experience in a broad range of vacuum and leak detection technologies. Courses are offered worldwide at convenient regional and customer locations.



On-site Service

On-site support is available for Leak Detectors and Large Rotary Vane Pumps.

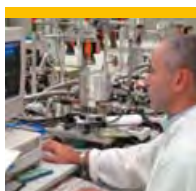

Qualified Staff

We back our global commitment with continuous attention to professional development and personal motivation for our staff. You expect proficiency in customer care, and we deliver it.



World-Class Quality

Conformance to procedures designed for global customer support allows us to satisfy the most demanding requirements. This is complemented by our continuous improvement and escalation processes.

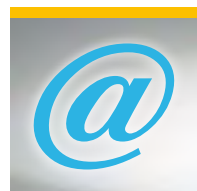

web

- Agilent website provides you immediate access to comprehensive product, application and support information www.agilent.com/chem/vacuum
- Agilent online store, lets you experience the power of purchasing made easy, with faster page loading, quicker transaction process, optimized search capabilities, and a user-friendly interface www.agilent.com/chem/store
- Agilent Vacuum-Choice gives you access to current special offers, promotions and news on vacuum products www.vacuum-choice.com



Applications Support

To meet your most demanding vacuum requirements, our experienced applications engineering team helps you find dedicated solutions, tailored to your specific technical needs.



Worldwide Parts Sourcing Plan Three Progressive Levels of Support

Agilent offers three convenient Service Programs to help you maximize your productivity:



Focus on What You Do Best

Take the advantage of Agilent Vacuum Service in your region.

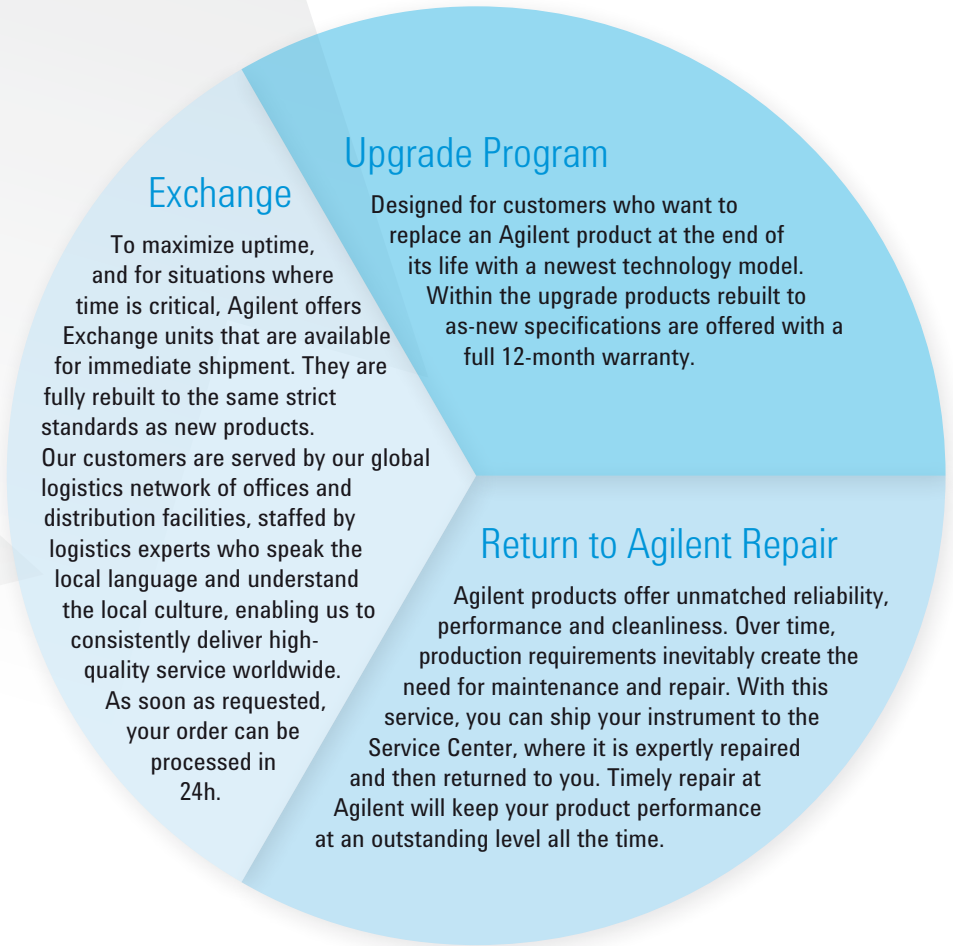

Repair Centers

Agilent Vacuum has manufacturing plants in North America (Lexington, MA), Europe (Torino and Valmadrera, Italy) and Asia (Penang, Malaysia), and a network of Regional Repair Centers located in US, Europe, India, China and Singapore.

These Repair Centers :

- are authorized service providers and use only genuine Agilent parts
- are guaranteed to have the latest equipment procedures and upgrades
- repair your equipment rapidly at predictable repair costs



AGILENT ROTARY VANE PUMPS

- 2-3 Features and Benefits
- 4-5 Typical Applications
- 6-19 Pump Models
- 20 Accessories
- 21 HS Series Pumps Features and Benefits
- 22-25 HS Series Pump Models
- 26-27 MS 40+ Pump Features and Benefits
- 28-29 MS 40+ Pump Model



Agilent Technologies

AGILENT ROTARY VANE PUMPS FEATURES AND BENEFITS

A reliable line of pumps to cover the most demanding industrial and scientific applications

- Thanks to a very simple and highly reliable design, these field proven rotary vane pumps provide excellent vacuum performance. Agilent's quality and manufacturing standards ensure that the DS Rotary Vane Pumps provide high pumping stability for light gases, low noise, minimal oil backstreaming, and a long operating life.
- Agilent's DS Rotary Vane Pumps conform with CE and RoHS requirements, and all pumps are UL and CSA approved. Agilent's world class technical support organization makes the DS Rotary Vane Pump cost-effective and well suited for a wide range of applications.

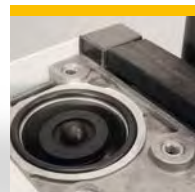

Anti-suckback Valve and Vent Device

- This valve isolates the pump should it stop or be idle
- Prevents inadequate venting and oil contamination of the vacuum system when the pump is switched off, or in case of power fail



The new MS 40+ Mono Stage Rotary Vane Pump

- High capacity pumping speed with the smallest footprint
- Proven inverter technology
- Ideal for mass spectrometry and electron microscopy
- Lowest noise, highest throughput



HS Series "smart" pumps with green technology

- In 2004 Varian, now Agilent, introduced the first rotary vane pumps with truly "smart" capabilities
- Employ an innovative frequency inverter technology to deliver optimal and consistent performance
- Encompass the worldwide range of voltage and frequency conditions
- Environmentally friendly thanks to reduced power requirements and low start up current

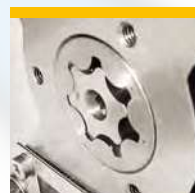

Forced Oil Circulation

- The dedicated oil circulation gear pump ensures efficient and reliable lubrication of the pump from atmospheric pressure throughout the entire vacuum operating range

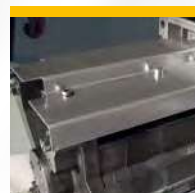

Built-in Oil Shield

- This feature minimizes the oil mist at the pump exhaust
- Drastically reduces the oil consumption over long periods of operation
- Reduction of air pollution limiting the impact on the environment

ROTARY VANE PUMPS



Dual Stage Pumps

DS Series: the two stage design allows:

- Low 10^{-3} mbar operation
- Low operating temperature
- Minimal backstreaming at low pressure
- Good pumping efficiency and gas ballast in the low 10^{-2} mbar region



Worldwide Motors

- Pump motors, available as 1-phase or 3-phase, are suitable for all voltages and frequencies worldwide
- Operational voltages are easily selectable, allowing greater flexibility, easy planning and inventory reduction



Socket Type IEC320

- Permits use of standard power cable
- Eliminates the need to open box and wire the motor

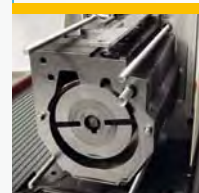
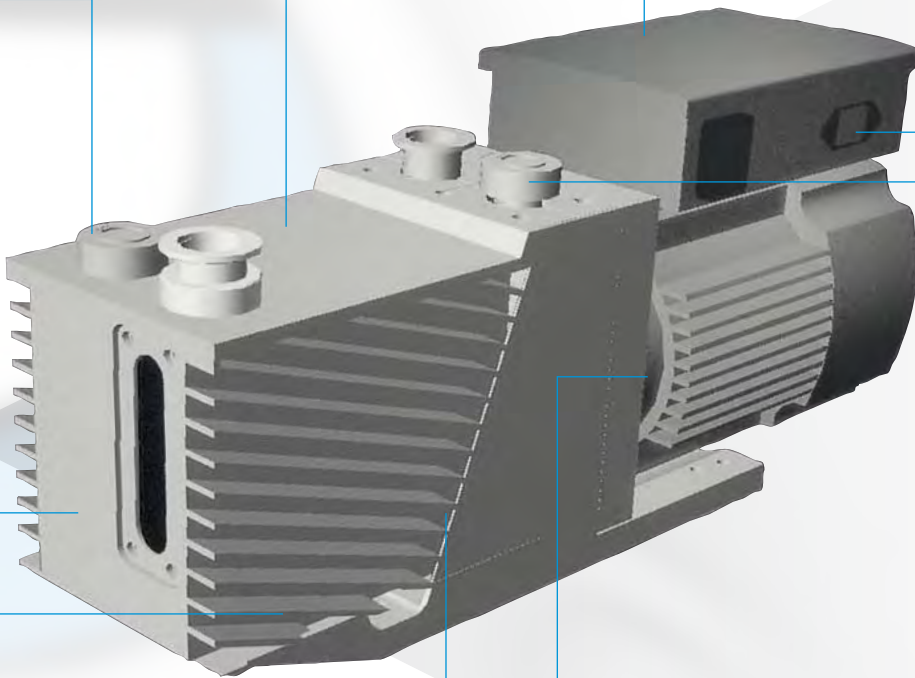

Gas Ballast Valve

- The opening of this valve injects dry air into the second stage of the pump
- This action increases the temperature of the module which facilitates the outgassing and clean up of water vapor or other condensable gases from the oil

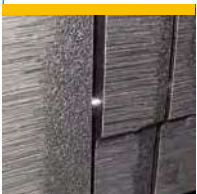

Alignment Pins on Pump Module

- The pump module components are assembled and positioned by built-in alignment pins
- These speed up the assembling and maintenance process, avoiding any error

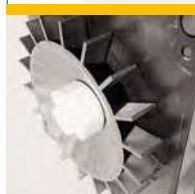

Forced Air Ventilation

The cooling fan between the motor and the pump:

- Reduces the pump operating temperature
- Lowers the oil vapor partial pressure
- Minimizes oil backstreaming and vacuum system contamination

AGILENT ROTARY VANE PUMPS TYPICAL APPLICATIONS



ICP-MS. Photo courtesy Agilent Scientific Instruments.



Analytical Instruments and Mass Spectrometry

Rotary Vane Pumps are the most common primary vacuum pumps used on GC-MS, LC-MS, ICP-MS, and MALDI-TOF Instruments.

GC-MS typically uses our smallest pump, the DS42; the pump is needed to rough the system and back the high vacuum Turbo or Diffusion pump.

LC-MS and ICP-MS use a medium capacity pump on the sample injection/system interface, typically a DS402 or a DS602, and a smaller pump to back the system Turbo pumps.

MALDI-TOF depending on system size, uses the DS102 to the DS602 as roughing or interface pumps.

Nowadays high-end instruments, such as LC-MS and ICP-MS, can take advantage of the benefits of HS 452, HS 652 and MS 40+:

- Large pumping capacity
- Consistent worldwide performance thanks to universal voltage and frequency
- Single phase
- Low power requirements and start up current
- Remote control and diagnostic
- Adjustable performance, low noise
- Green technology

Electron Microscopes

Small pumps, typically the DS202 and the DS302, are still used in competition with dry pumps to rough the system and the high vacuum Turbo or Diffusion pump. condensable vapor.

Leak Detection

Pumps in the DS102, DS202 and DS302 range are typically used to back the Helium Mass Spectrometer Turbo or Diffusion pump.

The roughing pump is usually bigger, typically up to the DS402/DS602, and can still be installed on the Leak Detector itself, while bigger pumps can be used to pump down high throughput Leak Detection systems.

ROTARY VANE PUMPS



Freeze Drying equipment.

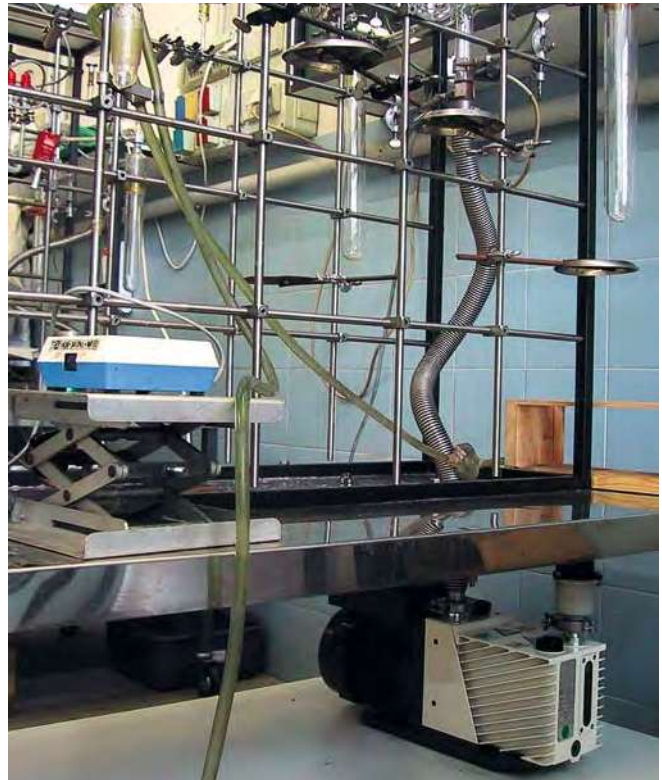

Distillation apparatus. Photo courtesy University of Torino, Italy.

Industrial Vacuum Processes

Vacuum coatings, Metallurgy Vacuum Furnaces, Lamps and TV Tube manufacture, Sterilizers, Freeze Dryers, Glove Boxes, High Speed Centrifuges, and Flywheels (for energy storage) represent the main Industrial applications for Dual Stage Rotary Vane pumps. In the first four fields of application the Rotary Pumps are used as roughing and backing pumps for High Vacuum Turbo or Diffusion pumps, while in the others the Rotary Pumps are typically the only vacuum pumps on the system.

High Energy Physics and Research Laboratories

In these applications the Rotary Vane pumps are mainly used in combination with Turbo pumps. The combination is typically used to rough and pump High Vacuum experimental chambers or to start Ion Pumps in ultra high vacuum systems.

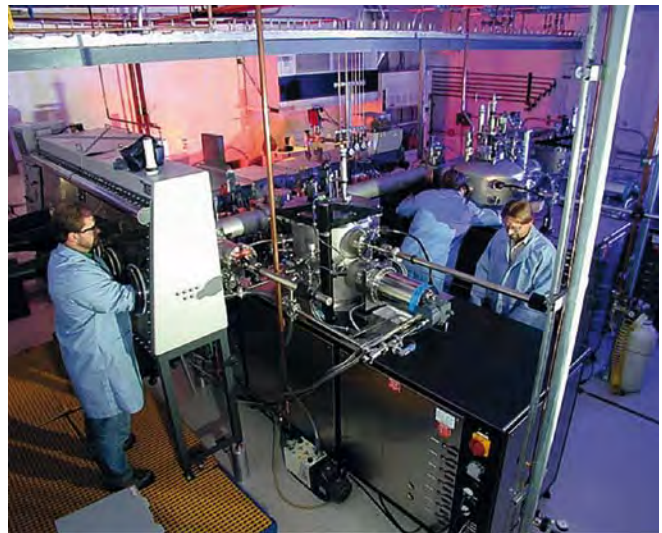

OLED-Lab. Photo courtesy PNNL.

AGILENT ROTARY VANE PUMP MODELS

		DS 42	DS 102	DS 202
Free air displacement	60 Hz l/min (cfm) 50 Hz l/min (m ³ /h)	45.5 (1.6) 38 (2.3)	114 (4) 95 (5.7)	192 (6.8) 160 (9.6)
Pumping speed*	60 Hz (cfm) 50 Hz (m ³ /h)	1.2 1.8	3.5 5	5.8 8.3
Ultimate partial pressure* (mbar)		10 ⁻⁴	10 ⁻⁴	10 ⁻⁴
Ultimate total pressure* (mbar)		4 x 10 ⁻³	2 x 10 ⁻³	2 x 10 ⁻³
Ultimate total pressure with gas ballast* (mbar)		2 x 10 ⁻²	2 x 10 ⁻²	2 x 10 ⁻²
Water vapor tolerance (mbar)		15	15	15
Water vapor capacity (g/h)		25	60	100
Oil capacity min/max (l)		0.5 (max)	0.2/0.5	0.2/0.6
Motor rating 1 ph	60 Hz (kW) 50 Hz (kW)	0.2 0.2	0.45 0.38	0.45 0.38
Motor rating 3 ph	60 Hz (kW) 50 Hz (kW)			
Nominal rotation speed	60 Hz (rpm) 50 Hz (rpm)	3480 2280	1800 1500	1800 1500
Weight kg (lbs)		11 (24)	22 (48)	25 (55)
Inlet flange		16KF DN	25KF DN	25KF DN
Exhaust flange		16KF DN	25KF DN	25KF DN

*According to PNEUROP 6602



ROTARY VANE PUMPS

DS 302	DS 402	DS 602	HS 452	HS 652	MS 40+
285 (10) 237 (14.2)	410 (14.5) 342 (20.5)	605 (21.4) 504 (30.2)	456 (16.1) 456 (27.3)	672 (23.8) 672 (40.3)	828 (29.2) 828 (49.7)
8.2 11.6	12.3 17.4	17.6 25	13 22	19 32	23.5 40
10 ⁻⁴	10 ⁻⁴	10 ⁻⁴	10 ⁻⁴	10 ⁻⁴	N/A
2 x 10 ⁻³	2 x 10 ⁻³	2 x 10 ⁻³	2 x 10 ⁻³	2 x 10 ⁻³	5 x 10 ⁻²
2 x 10 ⁻²	1 x 10 ⁻²	1 x 10 ⁻²	1 x 10 ⁻²	1 x 10 ⁻²	N/A No gas ballast port
20	30	30	30	30	N/A No gas ballast port
160	350	550	350	550	N/A No gas ballast port
0.25/0.6	0.5/1	0.5/1	0.5/1	0.5/1	1
0.45 0.38	0.90 0.75	0.90 0.75			
	0.90 0.75	0.90 0.75	0.50	0.50	0.75
1800 1500	1800 1500	1800 1500	2000	2000	1450
25 (55)	35 (77)	35 (77)	33 (73)	33 (73)	33 (73)
25KF DN	25KF DN	25KF DN	25KF DN	25KF DN	25KF DN - 40KF DN
25KF DN	25KF DN	25KF DN	25KF DN	25KF DN	25KF DN



AGILENT ROTARY VANE PUMP MODELS

▶ Agilent DS 42

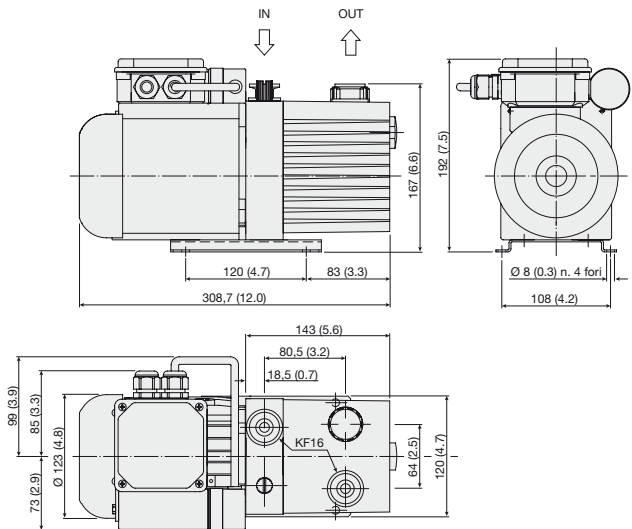

Dimensions: millimeters (inches)

Technical Specifications

Free air displacement	60 Hz: 45.5 l/min (1.6 cfm)	50 Hz: 38 l/min (2.3 m ³ /h)
Pumping speed*	60 Hz: 1.2 cfm	50 Hz: 1.8 m ³ /h
Ultimate partial pressure*	10 ⁻⁴ mbar	
Ultimate total pressure*	4 x 10 ⁻³ mbar	
Ultimate total pressure with gas ballast*	2 x 10 ⁻² mbar	
Water vapor tolerance	15 mbar	
Water vapor capacity	25 g/h	
Oil capacity max	0.5 l	
Motor rating 1ph	60 Hz: 0.2 kW	50 Hz: 0.2 kW
Nominal rotation speed	60 Hz: 3480 rpm	50 Hz: 2280 rpm
Weight	11 kg (24 lbs)	
Inlet flange	16KF DN	
Exhaust flange	16KF DN	

* According to PNEURO P 6602

ROTARY VANE PUMPS

DS 42 - Pump Speed Curve

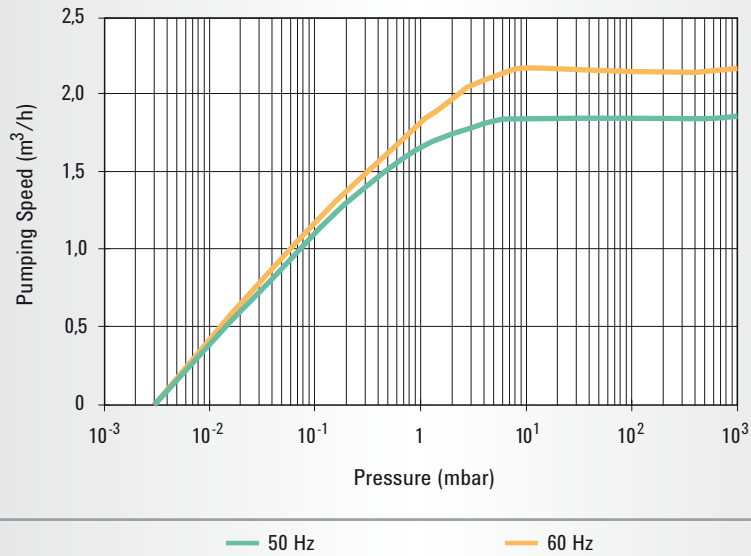

Ordering Information

Dual Stage Rotary Vane Pump	Part Number
DS 42 120V-60Hz	9499308
DS 42 220-240V - 50/60Hz	9499309

Power cable not available.

The correct cable for electrical wiring is a three wires (Ph+N+Earth) cable. The wire section has to be at least 1 mm² (AWG17), and the cable external diameter has to be between 7 mm to 12 mm.

Oil and Accessories	Part Number
Rotary vane fluid, DS31 type, 0.5 liter	9499305
Oil mist eliminator KF16	9499388
Oil mist eliminator 3/4 G	9499387
DS 42 filter cartridge (pkg. of 2)	9499386
Oil drain extension	9499375
NW 16 centering ring Viton	KC16AV
NW 16 aluminum clamp	KQ16AWP

AGILENT ROTARY VANE PUMP MODELS

▶ Agilent DS 102

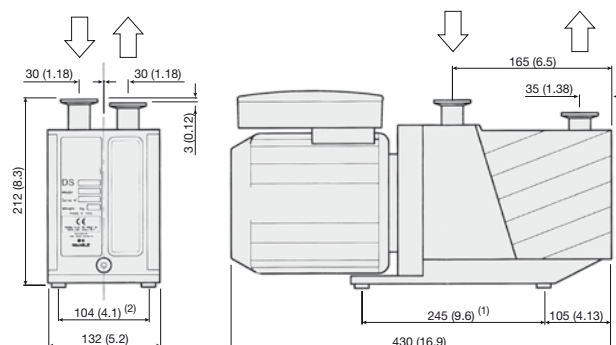

Alternative mounting holes are also available, with (1) = 226 (8.9) and (2) = 98 (3.8), with hole $\varnothing = 7$ (0.3)

Dimensions: millimeters (inches)

Technical Specifications

Free air displacement	60 Hz: 114 l/min (4 cfm)	50 Hz: 95 l/min (5.7 m ³ /h)
Pumping speed*	60 Hz: 3.5 cfm	50 Hz: 5 m ³ /h
Ultimate partial pressure*		10 ⁻⁴ mbar
Ultimate total pressure*		2 x 10 ⁻³ mbar
Ultimate total pressure with gas ballast*		2 x 10 ⁻² mbar
Water vapor tolerance		15 mbar
Water vapor capacity		60 g/h
Oil capacity min/max		0.2/0.5 l
Motor rating 1ph	60 Hz: 0.55 kW	50 Hz: 0.45 kW
Nominal rotation speed	60 Hz: 1800 rpm	50 Hz: 1500 rpm
Weight		22 kg (48 lbs)
Inlet flange		25KF DN
Exhaust flange		25KF DN

* According to PNEURO P 6602

ROTARY VANE PUMPS

DS 102 - Pump Speed Curve

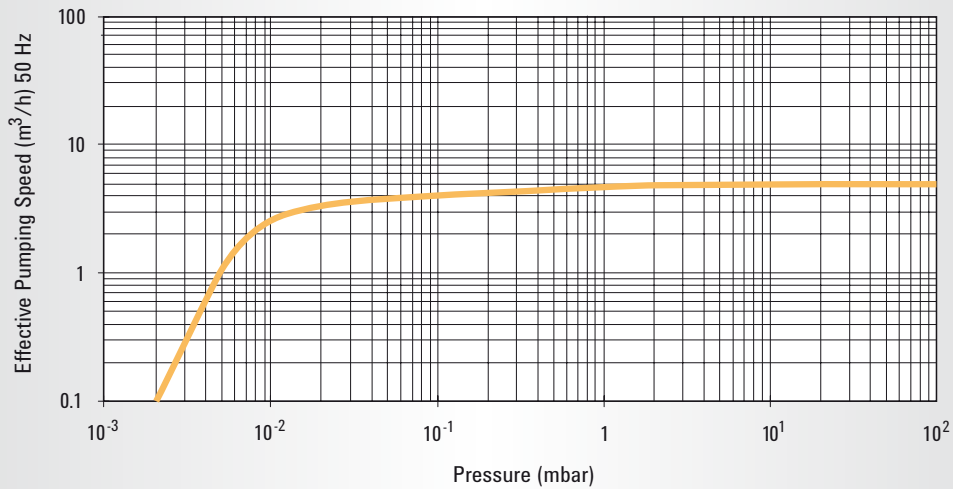

Ordering Information

Dual Stage Rotary Vane Pump	Part Number
DS 102 with 1 phase worldwide motor*	9499315
* 1 phase motors (100-120 / 200-230) V ±10%, 50/60 Hz. All motors comply with CE and UL/CSA standards.	
Minor Maintenance Kit	Part Number
Contains all the valves, O-rings and seals to refurbish the pump to vacuum integrity	9499370
Major Maintenance Kit	Part Number
Includes all the items of the minor kit plus the vanes	9499380

Oil and Accessories	Part Number
Rotary vane fluid, DS19 type, 1 liter	9499390
Rotary vane fluid, DS19 type, 1 liter (USA)*	K7516301
Rotary vane fluid, DS19 type, 1 gallon (USA)	K7516302
Oil mist eliminator	9499395
Oil mist replacement cartridge (pkg. of 2)	9499394
NW 25 oil exhaust filter	9499392
NW 25 oil exhaust replacement cartridge	9499342
Oil return kit	9499376
Oil drain extension	9499375
European plug power cable 2 meters 1 ph	9499396
USA plug power cable 2 meters 1 ph	9499397
UK plug power cable 2 meters 1 ph	9499398
NW 25 centering ring Viton	KC25AV
NW 25 aluminum clamp	KQ25AWP

* When these pumps are used in Leak Detectors applications, we recommend the use of Rotary Vane Fluid (Elite-Z mechanical), P/N 695409005 as it features a lower vapor pressure.

AGILENT ROTARY VANE PUMP MODELS

▶ Agilent DS 202

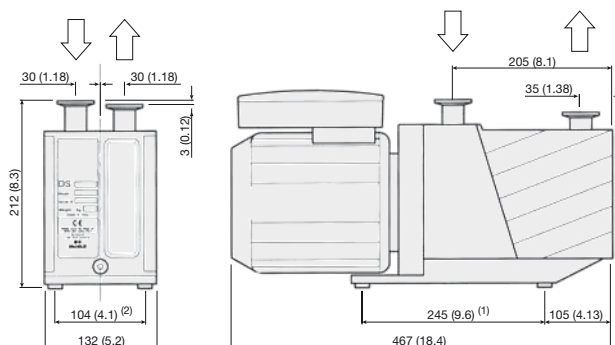

Alternative mounting holes are also available, with (1) = 226 (8.9) and (2) = 98 (3.8), with hole $\varnothing = 7$ (0.3)

Dimensions: millimeters (inches)

Technical Specifications

Free air displacement	60 Hz: 192 l/min (6.8 cfm)	50 Hz: 160 l/min (9.6 m ³ /h)
Pumping speed*	60 Hz: 5.8 cfm	50 Hz: 8.3 m ³ /h
Ultimate partial pressure*		10 ⁻⁴ mbar
Ultimate total pressure*		2 x 10 ⁻³ mbar
Ultimate total pressure with gas ballast*		2 x 10 ⁻² mbar
Water vapor tolerance		15 mbar
Water vapor capacity		100 g/h
Oil capacity min/max		0.25/0.6 l
Motor rating 1ph	60 Hz: 0.55 kW	50 Hz: 0.45 kW
Nominal rotation speed	60 Hz: 1800 rpm	50 Hz: 1500 rpm
Weight		25 kg (55 lbs)
Inlet flange		25KF DN
Exhaust flange		25KF DN

* According to PNEURO P 6602

ROTARY VANE PUMPS

DS 202 - Pump Speed Curve

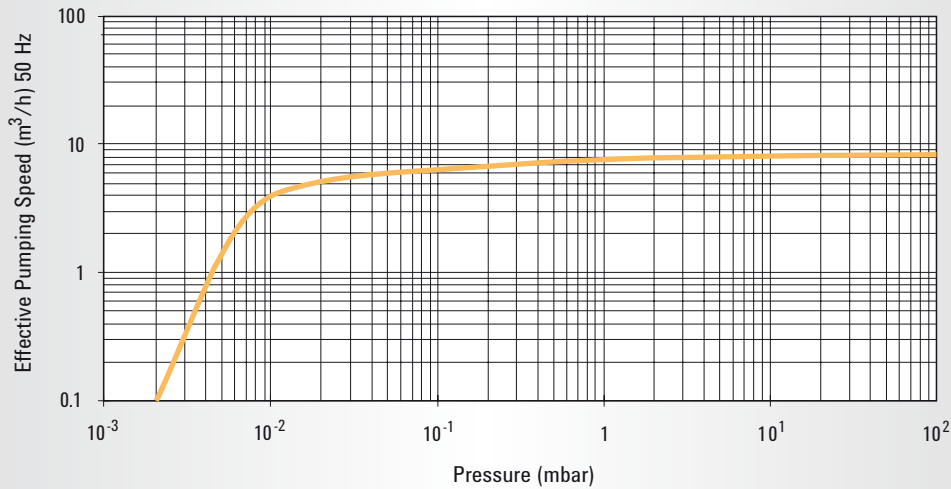

Ordering Information

Dual Stage Rotary Vane Pump	Part Number
DS 202 with 1 phase worldwide motor*	9499320
* 1 phase motors (100-120 / 200-230) V ±10%, 50/60 Hz. All motors comply with CE and UL/CSA standards.	
Minor Maintenance Kit	Part Number
Contains all the valves, O-rings and seals to refurbish the pump to vacuum integrity	9499370
Major Maintenance Kit	Part Number
Includes all the items of the minor kit plus the vanes	9499381

Oil and Accessories	Part Number
Rotary vane fluid, DS19 type, 1 liter	9499390
Rotary vane fluid, DS19 type, 1 liter (USA)*	K7516301
Rotary vane fluid, DS19 type, 1 gallon (USA)	K7516302
Oil mist eliminator	9499395
Oil mist replacement cartridge (pkg. of 2)	9499394
NW 25 oil exhaust filter	9499392
NW 25 oil exhaust replacement cartridge	9499342
Oil return kit	9499376
Oil drain extension	9499375
European plug power cable 2 meters 1 ph	9499396
USA plug power cable 2 meters 1 ph	9499397
UK plug power cable 2 meters 1 ph	9499398
NW 25 centering ring Viton	KC25AV
NW 25 aluminum clamp	KQ25AWP

* When these pumps are used in Leak Detectors applications, we recommend the use of Rotary Vane Fluid (Elite-Z mechanical), P/N 695409005 as it features a lower vapor pressure.

AGILENT ROTARY VANE PUMP MODELS

▶ Agilent DS 302

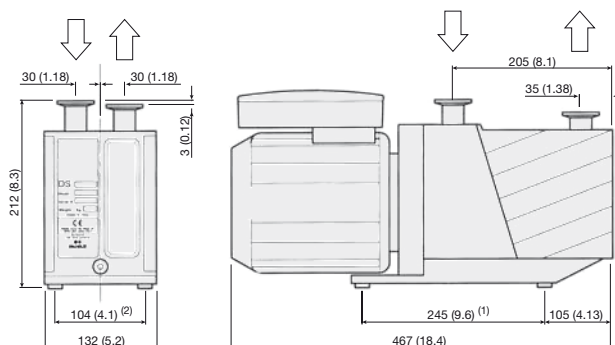

Alternative mounting holes are also available, with (1) = 226 (8.9) and (2) = 98 (3.8), with hole $\varnothing = 7$ (0.3)

Dimensions: millimeters (inches)

Technical Specifications

Free air displacement	60 Hz: 285 l/min (10 cfm)	50 Hz: 237 l/min (14.2 m ³ /h)
Pumping speed*	60 Hz: 8.2 cfm	50 Hz: 11.6 m ³ /h
Ultimate partial pressure*		10 ⁻⁴ mbar
Ultimate total pressure*		2 x 10 ⁻³ mbar
Ultimate total pressure with gas ballast*		2 x 10 ⁻² mbar
Water vapor tolerance		20 mbar
Water vapor capacity		160 g/h
Oil capacity min/max		0.25/0.6 l
Motor rating 1ph	60 Hz: 0.55 kW	50 Hz: 0.45 kW
Nominal rotation speed	60 Hz: 1800 rpm	50 Hz: 1500 rpm
Weight		25 kg (55 lbs)
Inlet flange		25KF DN
Exhaust flange		25KF DN

* According to PNEURO P 6602

ROTARY VANE PUMPS

DS 302 - Pump Speed Curve

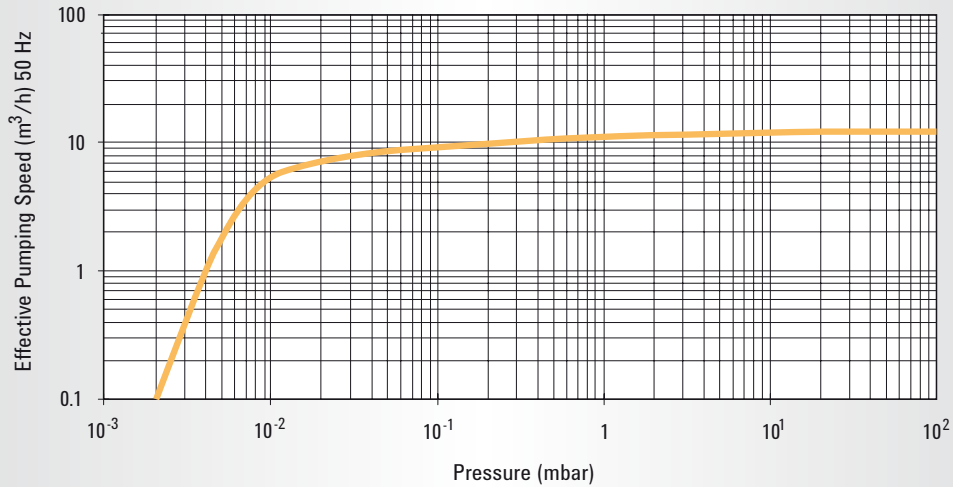

Ordering Information

Dual Stage Rotary Vane Pump	Part Number
DS 302 with 1 phase worldwide motor*	9499325
* 1 phase motors (100-120 / 200-230) V ±10%, 50/60 Hz. All motors comply with CE and UL/CSA standards.	
Minor Maintenance Kit	Part Number
Contains all the valves, O-rings and seals to refurbish the pump to vacuum integrity	9499370
Major Maintenance Kit	Part Number
Includes all the items of the minor kit plus the vanes	9499381

Oil and Accessories	Part Number
Rotary vane fluid, DS19 type, 1 liter	9499390
Rotary vane fluid, DS19 type, 1 liter (USA)*	K7516301
Rotary vane fluid, DS19 type, 1 gallon (USA)	K7516302
Oil mist eliminator	9499395
Oil mist replacement cartridge (pkg. of 2)	9499394
NW 25 oil exhaust filter	9499392
NW 25 oil exhaust replacement cartridge	9499342
Oil return kit	9499376
Oil drain extension	9499375
European plug power cable 2 meters 1 ph	9499396
USA plug power cable 2 meters 1 ph	9499397
UK plug power cable 2 meters 1 ph	9499398
NW 25 centering ring Viton	KC25AV
NW 25 aluminum clamp	KQ25AWP

* When these pumps are used in Leak Detectors applications, we recommend the use of Rotary Vane Fluid (Elite-Z mechanical), P/N 695409005 as it features a lower vapor pressure.

AGILENT ROTARY VANE PUMP MODELS

▶ Agilent DS 402

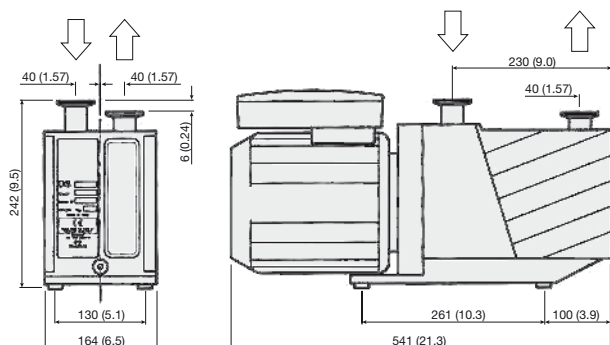

Technical Specifications

Free air displacement	60 Hz: 410 l/min (14.5 cfm)	50 Hz: 342 l/min (20.5 m ³ /h)
Pumping speed*	60 Hz: 12.3 cfm	50 Hz: 17.4 m ³ /h
Ultimate partial pressure*		10 ⁻⁴ mbar
Ultimate total pressure*		2 x 10 ⁻³ mbar
Ultimate total pressure with gas ballast*		1 x 10 ⁻² mbar
Water vapor tolerance		30 mbar
Water vapor capacity		350 g/h
Oil capacity min/max		0.5/1 l
Motor rating 1ph	60 Hz: 0.55 kW	50 Hz: 0.75 kW
Motor rating 3ph	60 Hz: 0.90 kW	50 Hz: 0.75 kW
Nominal rotation speed	60 Hz: 1800 rpm	50 Hz: 1500 rpm
Weight		35 kg (77 lbs)
Inlet flange		25KF DN
Exhaust flange		25KF DN

* According to PNEURO P 6602

ROTARY VANE PUMPS

DS 402 - Pump Speed Curve

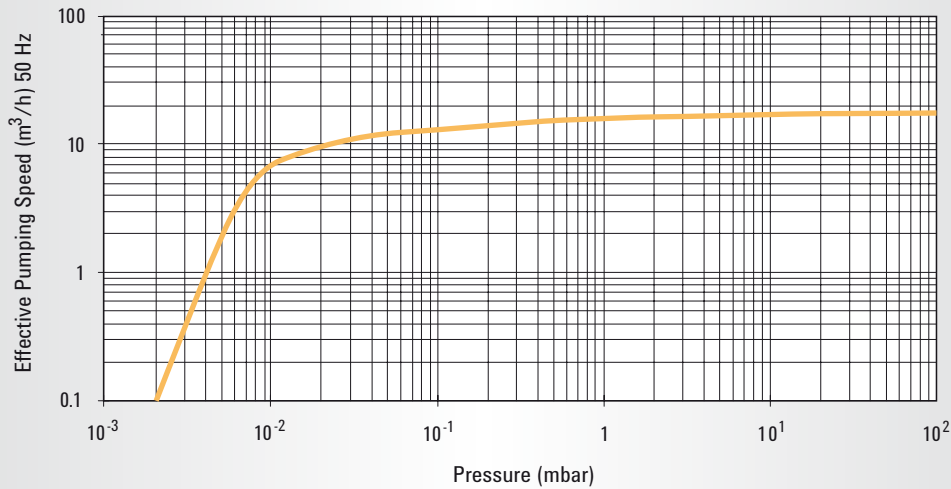

Ordering Information

Dual Stage Rotary Vane Pump	Part Number
DS 402 with 1 phase worldwide motor*	9499330
DS 402 with 3 phase worldwide motor**	9499331
* 1 phase motors (100-120 / 200-230) V ±10%, 50/60 Hz.	
** 3 phase motors (200-220 / 380-415) V ±10% at 50 Hz or (200-230 / 460) V ±10% at 60 Hz.	
All motors comply with CE and UL/CSA standards.	
Minor Maintenance Kit	Part Number
Contains all the valves, O-rings and seals to refurbish the pump to vacuum integrity	9499371
Major Maintenance Kit	Part Number
Includes all the items of the minor kit plus the vanes	9499382

Oil and Accessories	Part Number
Rotary vane fluid, DS19 type, 1 liter	9499390
Rotary vane fluid, DS19 type, 1 liter (USA)*	K7516301
Rotary vane fluid, DS19 type, 1 gallon (USA)	K7516302
Oil mist eliminator	9499395
Oil mist replacement cartridge (pkg. of 2)	9499394
NW 25 oil exhaust filter	9499392
NW 25 oil exhaust replacement cartridge	9499342
Oil return kit	9499376
Oil drain extension	9499375
European plug power cable 2 meters 1 ph	9499396
USA plug power cable 2 meters 1 ph	9499397
UK plug power cable 2 meters 1 ph	9499398
NW 25 centering ring Viton	KC25AV
NW 25 aluminum clamp	KQ25AWP

* When these pumps are used in Leak Detectors applications, we recommend the use of Rotary Vane Fluid (Elite-Z mechanical), P/N 695409005 as it features a lower vapor pressure.

AGILENT ROTARY VANE PUMP MODELS

▶ Agilent DS 602

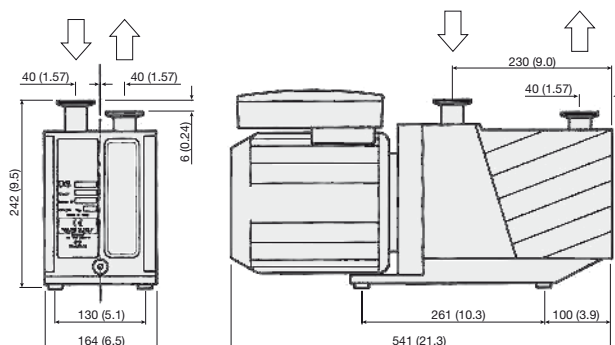

Alternative mounting holes are also available, with thread 1/4-20UNC

Dimensions: millimeters (inches)

Technical Specifications

Free air displacement	60 Hz: 605 l/min (21.4 cfm)	50 Hz: 504 l/min (30.2 m ³ /h)
Pumping speed*	60 Hz: 17.6 cfm	50 Hz: 25 m ³ /h
Ultimate partial pressure*		10 ⁻⁴ mbar
Ultimate total pressure*		2 x 10 ⁻³ mbar
Ultimate total pressure with gas ballast*		1 x 10 ⁻² mbar
Water vapor tolerance		30 mbar
Water vapor capacity		550 g/h
Oil capacity min/max		0.5/1 l
Motor rating 1ph	60 Hz: 0.90 kW	50 Hz: 0.75 kW
Motor rating 3ph	60 Hz: 0.90 kW	50 Hz: 0.75 kW
Nominal rotation speed	60 Hz: 1800 rpm	50 Hz: 1500 rpm
Weight		35 kg (77 lbs)
Inlet flange		25KF DN
Exhaust flange		25KF DN

* According to PNEURO P 6602

ROTARY VANE PUMPS

DS 602 - Pump Speed Curve

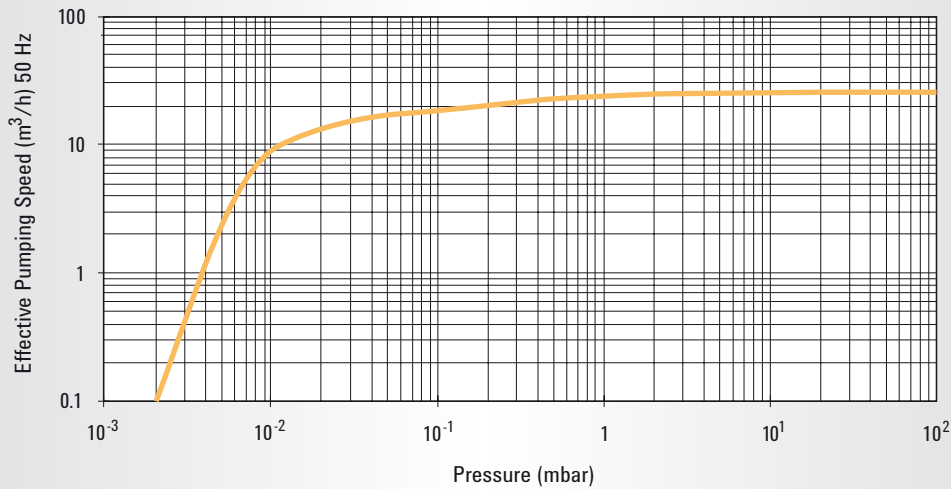

Ordering Information

Dual Stage Rotary Vane Pump	Part Number
DS 602 with 1 phase worldwide motor*	9499335
DS 602 with 3 phase worldwide motor**	9499336
* 1 phase motors (100-120 / 200-230) V ±10%, 50/60 Hz.	
** 3 phase motors (200-220 / 380-415) V ±10% at 50 Hz or (200-230 / 460) V ±10% at 60 Hz.	
All motors comply with CE and UL/CSA standards.	
Minor Maintenance Kit	Part Number
Contains all the valves, O-rings and seals to refurbish the pump to vacuum integrity	9499371
Major Maintenance Kit	Part Number
Includes all the items of the minor kit plus the vanes	9499382

Oil and Accessories	Part Number
Rotary vane fluid, DS19 type, 1 liter	9499390
Rotary vane fluid, DS19 type, 1 liter (USA)*	K7516301
Rotary vane fluid, DS19 type, 1 gallon (USA)	K7516302
Oil mist eliminator	9499395
Oil mist replacement cartridge (pkg. of 2)	9499394
NW 25 oil exhaust filter	9499392
NW 25 oil exhaust replacement cartridge	9499342
Oil return kit	9499376
Oil drain extension	9499375
European plug power cable 2 meters 1 ph	9499396
USA plug power cable 2 meters 1 ph	9499397
UK plug power cable 2 meters 1 ph	9499398
NW 25 centering ring Viton	KC25AV
NW 25 aluminum clamp	KQ25AWP

* When these pumps are used in Leak Detectors applications, we recommend the use of Rotary Vane Fluid (Elite-Z mechanical), P/N 695409005 as it features a lower vapor pressure.

AGILENT ROTARY VANE PUMP ACCESSORIES

▶ Exhaust Filters - Oil Mist Eliminator

The exhaust filters (below, left) and the oil mist eliminator (right), retain the oil vapors which would otherwise be expelled into the atmosphere during pumpdown and gas ballast operation.

Some models feature an oil return line to allow condensed oil or fluid to return to the pump reservoir.



Ordering Information

NW25 oil exhaust filter (left)	PN 9499392
Oil mist eliminator DS 102 - DS 602 (right)	PN 9499395

▶ Foreline Roughing Traps

Agilent's new traps are designed to prevent the backstreaming of mechanical pump fluids. Copper and stainless steel gauze inserts are designed to reduce oil backstreaming. Molecular sieve inserts are available for applications where it is desirable to increase water vapor pumping speed while eliminating backstreaming above the trap.



Ordering Information

Foreline/Roughing Traps: please call Agilent for ordering information

For any further details on our rotary vane pump accessories, please contact Agilent Vacuum Products.

Agilent Oil, GP Type Mechanical Pump Fluid

Agilent GP Type Fluid is a mechanical pump fluid recommended for use in non-corrosive applications. As a result of molecular distillation, it has low vapor pressure and, therefore, backstreams less than undistilled refinery products.

Ordering Information

Description	Part Number	Shipping Weight lbs (kg)
1 liter bottle	K7516301	3.5 (1.6)
1 gallon bottle	K7516302	14.0 (6.4)

AGILENT HS SERIES PUMPS FEATURES AND BENEFITS

ROTARY VANE PUMPS

- Agilent's HS 452 and HS 652 rotary vane pumps employ an innovative frequency inverter technology that delivers optimal and consistent performance throughout the worldwide range of voltage and frequency conditions.
- Operating with low power requirements, the microprocessor-controlled frequency inverter, combined with a 3-phase motor, is an efficient driving unit capable of delivering the high starting torque required for a dual-stage oil pump.
- Green technology: environmentally friendly thanks to reduced power requirements, low start up current, minimum oil mist at pump exhaust.



I/O and RS232/RS485 Communication

- Adjustable pumping speed from 45 to 68 Hz permits easy integration and reduces noise levels.
- Pump performance can be tailored to specific applications to reduce system costs.



Universal Input Voltage

- Truly universal single-phase voltage and frequency provide worldwide compatibility.
- Constant performance at different input frequencies.

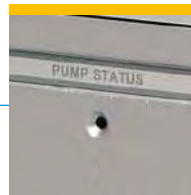

Remote Diagnostics

- Remote monitoring and control of oil consumption, power and current.
- Reduces maintenance costs, improves uptime and offers higher reliability.

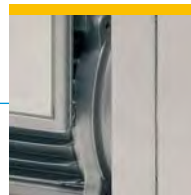

Reduced Power Requirements

- Inverter technology reduces the power required compared to traditional single phase motors.
- Circuit-breakers are no longer required, resulting in reduced system costs.

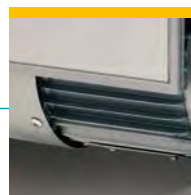

Higher Nominal Rotational Speed (2000 rpm)

- The pump is ideally suited for steady and high gas-load applications.

AGILENT ROTARY VANE PUMP MODELS

▶ Agilent HS 452

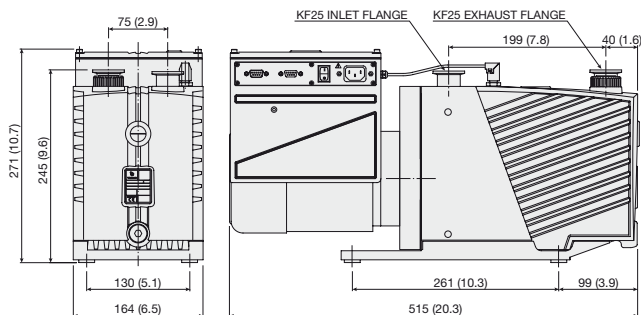

Dimensions: millimeters (inches)

The first rotary vane pumps with truly “smart” capabilities.

- Agilent’s HS 452 and HS 652 pumps employ an innovative frequency inverter technology that delivers optimal and consistent performance while encompassing the worldwide range of voltage and frequency conditions.
- Operating with low power requirements, the microprocessor controlled frequency inverter, combined with a 3-phase motor, is an efficient driving unit capable of delivering the high starting torque required of a dual-stage oil pump.
- HS 452 and HS 652 technology solves the common problems inherent in traditional single-phase motors. Smart Pumps start with inrush current about 7 times lower than that of equivalent traditional pumps.

- Unlike traditional pumps, Smart Pump’s software driven startup procedure recognizes faulty pumps within seconds, and so avoids uncontrolled load conditions. The result is very easy pump integration.
- The 3-phase inverter output is constant and independent of single-phase input frequencies and voltages. Motor efficiency and power factors remain optimal and as a result motor and pump wo asy to drive the pump. Pump performance can be tailored by setting the rotational speed for specific applications. The software monitors and logs pump parameters making it possible to perform pump and system diagnostics.

Technical Specifications

Free air displacement	27 m ³ /h (16 cfm)
Pumping speed*	22 m ³ /h (13 cfm)
Ultimate total pressure*	2 x 10 ⁻³ mbar
Ultimate total pressure with gas ballast*	1 x 10 ⁻² mbar
Operating voltage	100-120/200-240 V ±10%, 50/60 Hz
Inverter maximum output power	780 W
Nominal rotation speed	2000 rpm
Weight	33 kg (73 lbs)

* According to PNEURO P 6602

ROTARY VANE PUMPS

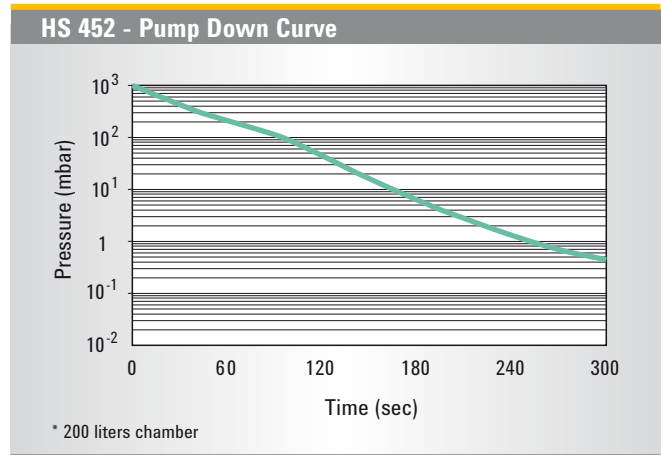
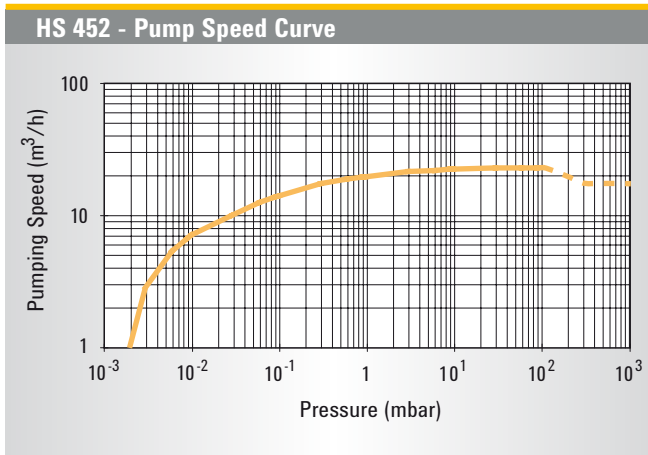

Ordering Information

Pump	Part Number
HS 452 Smart Pump 1 phase worldwide motor	9499360
IP44 accessory connector Kit	9499367

Accessories	Part Number
NW25 oil exhaust filter	9499392
Oil return kit	9499376
Oil drain extension	9499375
Rotary vane fluid, DS19 type, 1 liter	9499390
European plug power cable 2 meters 1 ph	9499396
USA plug power cable 2 meters 1 ph	9499397
UK plug power cable 2 meters 1 ph	9499398
Minor maintenance kit	9499371
Major maintenance kit	9499382

Application Note

Steady state high gas load applications exploit the major benefits of the smart technologies. When operated at pressures lower than the auto-tuning pressure, the HS 452 and HS 652 outperform the equivalent traditional DS 402 and DS 602 pumps by 10% at 60 Hz and by 30% at 50 Hz.

The Smart Pumps can run below auto-tuning pressure at their full speed of 2000 rpm. As shown in the pumping speed curve

at top right, the HS 452 has an auto-tuning pressure of 100 mbar while the HS 652 has an auto-tuning pressure of 40 mbar. Despite the lower power requirements of 780 W max, the Smart Pumps deliver good performance in the roughing phase. Fast cycling or inrush applications need to be evaluated on a case by case basis with our application engineers.

AGILENT ROTARY VANE PUMP MODELS

▶ Agilent HS 652

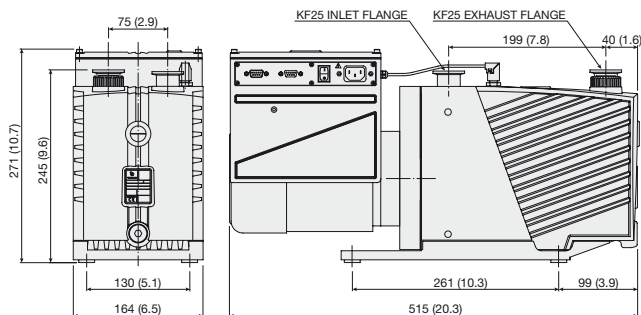

Dimensions: millimeters (inches)

The first rotary vane pumps with truly “smart” capabilities.

- Agilent’s HS 452 and HS 652 pumps employ an innovative frequency inverter technology that delivers optimal and consistent performance while encompassing the worldwide range of voltage and frequency conditions.
- Operating with low power requirements, the microprocessor controlled frequency inverter, combined with a 3-phase motor, is an efficient driving unit capable of delivering the high starting torque required of a dual-stage oil pump.
- HS 452 and HS 652 technology solves the common problems inherent in traditional single-phase motors. Smart Pumps start with inrush current about 7 times lower than that of equivalent traditional pumps.

- Unlike traditional pumps, Smart Pump’s software driven startup procedure recognizes faulty pumps within seconds, and so avoids uncontrolled load conditions. The result is very easy pump integration.
- The 3-phase inverter output is constant and independent of single-phase input frequencies and voltages. Motor efficiency and power factors remain optimal and as a result motor and pump working temperatures remain low and constant worldwide.
- Smart Pumps can be remotely driven via discrete I/O or RS232/RS485 interfaces. Agilent’s T-plus Navigator Software facilitates communication making it very easy to drive the pump. Pump performance can be tailored by setting the rotational speed for specific applications. The software monitors and logs pump parameters making it possible to perform pump and system diagnostics.

Technical Specifications

Free air displacement	40.3 m ³ /h (23.8 cfm)
Pumping speed*	32 m ³ /h (19 cfm)
Ultimate total pressure*	2 x 10 ⁻³ mbar
Ultimate total pressure with gas ballast*	1 x 10 ⁻² mbar
Operating voltage	100-120/200-240 V ±10%, 50/60 Hz
Inverter maximum output power	780 W
Nominal rotation speed	2000 rpm
Weight	33 kg (73 lbs)

* According to PNEURO P 6602

ROTARY VANE PUMPS

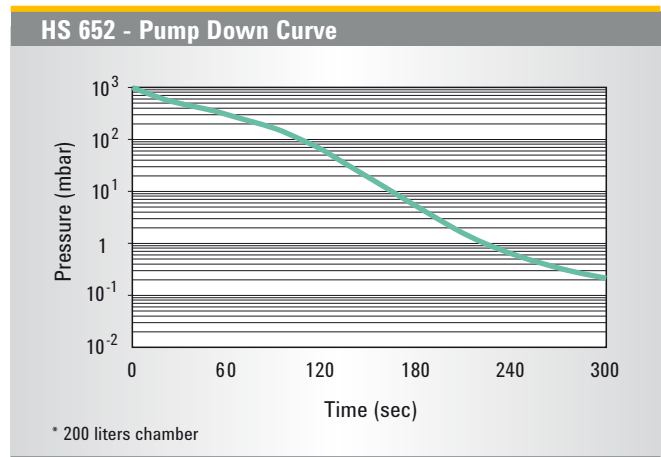
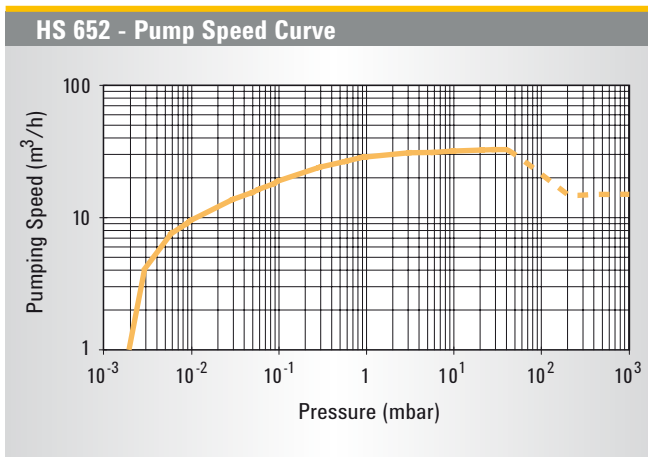

Ordering Information

Pump	Part Number
HS 652 Smart Pump 1 phase worldwide motor	9499365
IP44 accessory connector Kit	9499367

Accessories	Part Number
NW25 oil exhaust filter	9499392
Oil return kit	9499376
Oil drain extension	9499375
Rotary vane fluid, DS19 type, 1 liter	9499390
European plug power cable 2 meters 1 ph	9499396
USA plug power cable 2 meters 1 ph	9499397
UK plug power cable 2 meters 1 ph	9499398
Minor maintenance kit	9499371
Major maintenance kit	9499382

Application Note

Steady state high gas load applications exploit the major benefits of the smart technologies. When operated at pressures lower than the auto-tuning pressure, the HS 452 and HS 652 outperform the equivalent traditional DS402 and DS602 pumps by 10% at 60 Hz and by 30% at 50 Hz.

The Smart Pumps can run below auto-tuning pressure at their full speed of 2000 rpm. As shown in the pumping speed curve

at top right, the HS 452 has an auto-tuning pressure of 100 mbar while the HS 652 has an auto-tuning pressure of 40 mbar. Despite the lower power requirements of 780 W max, the Smart Pumps deliver good performance in the roughing phase. Fast cycling or inrush applications need to be evaluated on a case by case basis with our application engineers.

MS 40+ FEATURES AND BENEFITS

Mono Stage Rotary Vane Pump Small Footprint, High Pumping Capacity

- Sophisticated Electronics and excellent mechanical design allow high pumping capacity and reduced dimensions.
- Suitable for steady and high gas throughput conditions at pressures below 10 Torr, in applications like Mass Spectrometry (including LC-MS, ICP-MS, GC-TOF-MS, etc.), Electron Microscopy, and other Scientific Instrumentation.

Please contact Agilent to qualify use in cyclic applications.

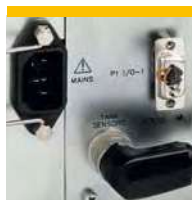

Interface Capabilities

- I/O and RS232/RS485 enable adjustment of operating parameters simplifying system integration
- Remote diagnostic allow the control of:
 - Oil level
 - Temperature
 - Power
 - Current



T-Plus Software

- T-Plus software allows control of pump parameters via PC, improving uptime and reliability, and reducing maintenance costs



Worldwide Service Capability

- Three levels of Product Support
 - 24h Advance Exchange
 - Factory Repair
 - Upgrade Programallow global coverage of service needs to maximize productivity and uptime

ROTARY VANE PUMPS



Inverter Technology

- Proven on-board electronics allows constant performance worldwide
- Truly universal voltage and frequency
- Single phase
- Inverter electronics enable tailoring pumping speed to each application

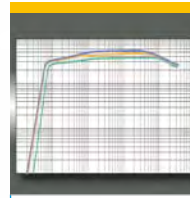

Highest Performances / Size Ratio

- Base pressure below 5×10^{-2} mbar (3.75×10^{-2} Torr)
- High pumping speed over a wide range, from atmosphere to 1 mbar (0.75 Torr)
- Inverter technology allows to manage pumping speed to more than $45 \text{ m}^3/\text{h}$ (26.5 cfm)
- Best noise level, with the highest throughput

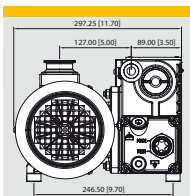

Smallest Dimensions

- The smallest single stage $40 \text{ m}^3/\text{h}$ pump in the market. $297 \times 418 \times 225 \text{ mm}$ (11.69 x 16.46 x 8.86 inches)
- Including on-board electronics, anti suck-back valve, integrated exhaust filter and oil return kit
- Easier system integration
- Simple maintenance
- Allows smaller overall instrument design, therefore reducing costs



Green Technology

- Environmentally friendly and cost-effective due to reduced power requirements, low start up current ($< 10 \text{ A}$) and stand by mode

AGILENT ROTARY VANE PUMP MODELS

▶ Agilent MS 40+

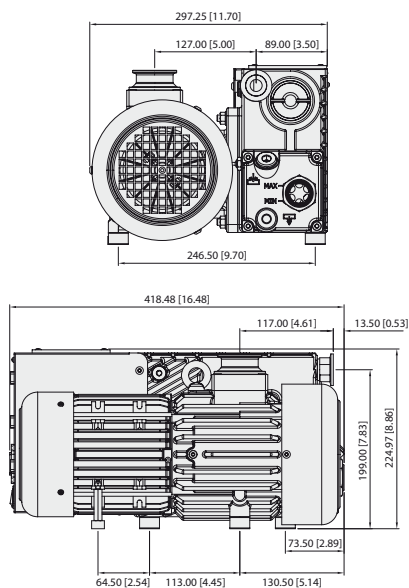

Dimensions: millimeters (inches)

Technical Specifications

	9499225	9499240	9499241
Free air displacement	828 l/min (29.2 cfm; 49.7 m ³ /h)	828 l/min (29.2 cfm; 49.7 m ³ /h)	828 l/min (29.2 cfm; 49.7 m ³ /h)
Pumping speed (at 5 mbar inlet pressure)	40 m ³ /h	40 m ³ /h	40 m ³ /h
Ultimate total pressure*	5x10 ⁻² mbar	5x10 ⁻² mbar	5x10 ⁻² mbar
Oil capacity min/max	1 l	1 l	1 l
Motor rating 1ph	0.75 kW	0.75 kW	0.75 kW
Noise level with gas ballast closed	≤ 62 dB(A)	≤ 62 dB(A)	≤ 62 dB(A)
Oil temperature (pump operating)	60 °C 140 °F	60 °C 140 °F	60 °C 140 °F
IP Value		20	
Installation category		II	
Pollution degree		2	
Operating temperature range	12-40 °C	12-40 °C	12-40 °C
Nominal rotation speed	1450 rpm	1450 rpm	1450 rpm
Weight	33 kg (73 lbs)	33 kg (73 lbs)	33 kg (73 lbs)
Inlet flange	25KF DN	40KF DN	40KF DN
Exhaust flange	25KF DN	25KF DN	25KF DN
Dimensions:			
- length	418 mm	418 mm	418 mm
- width	297 mm	297 mm	297 mm
- height	228 mm	228 mm	228 mm
Nominal Input Voltage	200-240 V	200-240 V	200-240 V
Input frequency	50/60 Hz	50/60 Hz	50/60 Hz
Max input power	1200 VA	1200 VA	1200 VA
Internal Main Fuse (TT type)	12.5 A	12.5 A	12.5 A

* According to PNEURO P 6602 - No gas ballast port

ROTARY VANE PUMPS

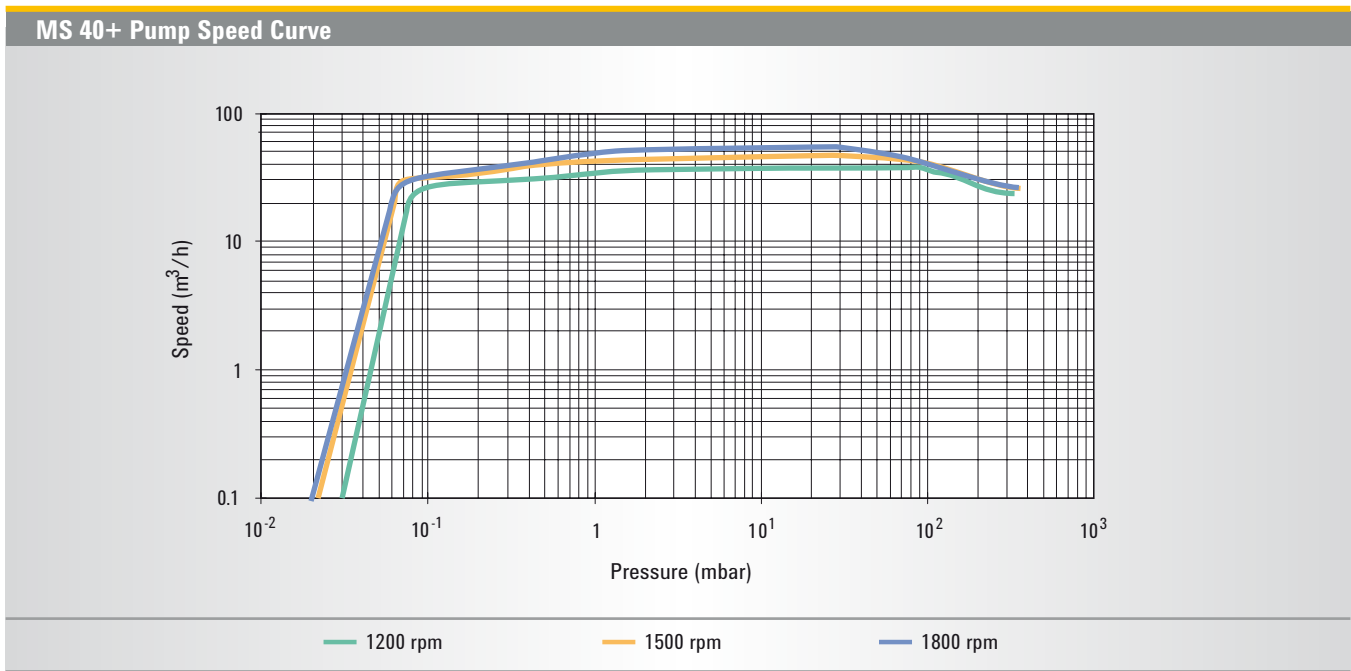

Ordering Information

Dual Stage Rotary Vane Pump	Part Number
MS 40+ RVP, 25KF Inlet Flange, with I/O and RS232/485 Interface, without Oil Level Sensor	9499225
MS 40+ RVP, 40KF Inlet Flange, Full Optional with I/O and RS232/485 Interface, with Oil Level Sensor	9499240
MS 40+ RVP, 40KF Inlet Flange, Base Version	9499241

Oil and Accessories	Part Number
MS 40+ Exhaust filter	9499201
MS 40+ 1 Litre Oil Tank	9499202
MS 40+ Maintenance Kit	9499203
Power cable EU	9499396
208Vac US Power cable	9499400
Power cable UK	9499398
Power cable IEC320	9499399
T-PLUS Navigator SW (w/serial cable)	9699883



AGILENT ROUGH VACUUM PUMPS

- 2 Introduction
- 3 Applications
- 4 Compact Single Stage Rotary Vane Pumps
- 5 Oil Lubricated Vane Pumps for Oxygen
- 6 Single Stage Rotary Vane Pumps
- 7 Oil Lubricated Vane Vacuum Pumps for Atex Environment
- 8 Dual Stage Oil Lubricated Rotary Vane Pumps
- 9 Dry Claw Vacuum Pumps
- 10 Roots Vacuum Pumps with Bypass Valve
- 11 Vacuum Blowers
- 12 Compact Vacuum Groups
- 13 Roots Pumps with Canned Motors and Atex Certification
- 14 Customized Vacuum Systems
- 15 Central Vacuum Systems for Hospital
- 16-17 Central Vacuum Systems
- 18-19 Accessories

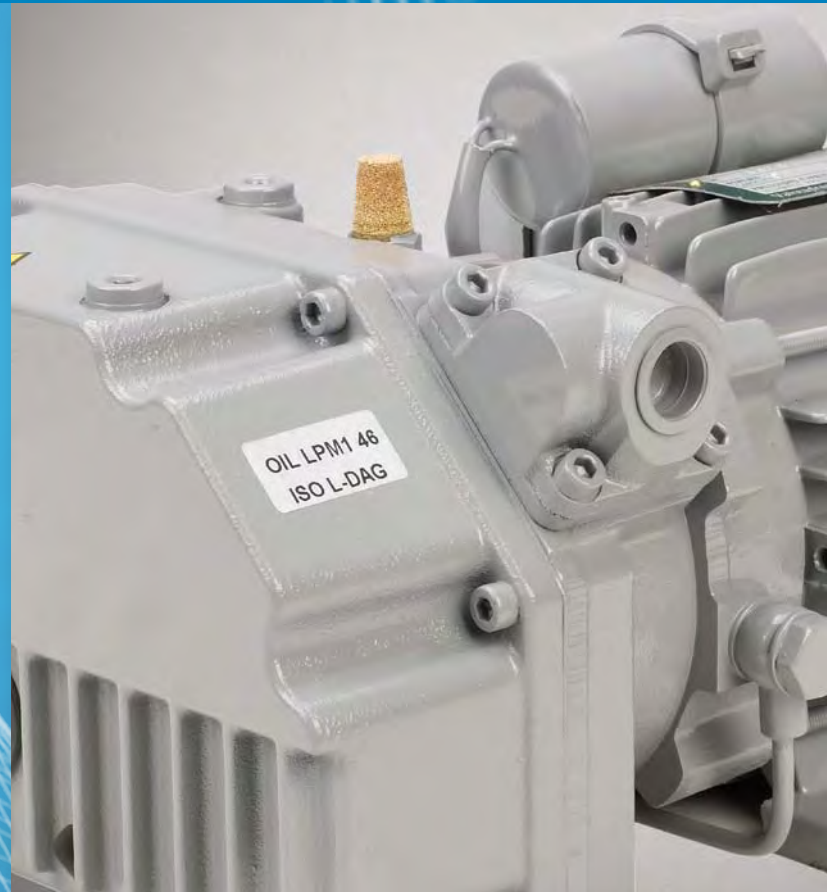

Agilent Technologies

P.V.R. is now Agilent Technologies expanding its Vacuum Products portfolio

With the acquisition of P.V.R., Agilent Vacuum Products Division expands its vacuum products offer for industrial applications.

P.V.R.'s products complement Agilent's existing vacuum portfolio, which includes high vacuum pumps, dry and wet primary pumps, and vacuum instrumentation. Joining together as one company will increase the ability to serve customers faster and better with a broader range of vacuum solutions.



Agilent VPD Plant, Valmadrera (LC), Italy.



Agilent VPD Plant, Lexington, MA.



Agilent VPD Plant, Torino, Italy.



Agilent VPD Plant, Penang, Malaysia.



APPLICATIONS

ROUGH VACUUM PUMPS



Food Industry

- Packaging machines
- Packaging machines with modified atmosphere
- Vacuum chambers
- Thermoforming machines
- De-aeration tunnels
- Tumblers machines
- Bottle fillings
- Milk production
- Freezing chambers
- Evisceration systems
- Meat extruders
- Central vacuum systems
- Pneumatic conveying systems



Chemical & Pharmaceutical

- Oil recovering plants
- Chemical processes
- Degassing materials
- Varnish mixers
- Drying medicinal products
- Pneumatic conveying plants
- Solvent recovery systems
- Distillation systems



Electrical Industry

- Drying transformer systems
- Motor/transformer impregnation process
- Granule conveying systems
- Plastic extruders
- Pick & place systems
- Oil recovery systems



Medical

- Hospital central vacuum
- Dental equipments



Paper & Wood Industry

- Wood drying chambers
- CNC Routers machines
- Pick & place systems
- Printing machines
- Packaging materials



Other Applications

- Soil decontamination
- Brick and pottery industries
- Marble and agglomerates
- Water waste recovery systems
- Glass industry
- Pneumatic conveying
- Battery industry
- Laminated materials
- Watches industry

COMPACT SINGLE STAGE ROTARY VANE PUMPS

▶ EM Series



EM 4



EM 8



EM 20

The single stage oil lubricated vacuum pumps of the EM series have been designed to meet the requirements of OEM customers for the various industrial fields.

Main features: Compact size and reduced weight - Gas ballast

valve (except for EM 4) - Check valve (except for EM 4) - Multivoltage and multifrequency motors - Quiet running - High pumping speed - Easy to install - Continuous operation at poor vacuum levels (/B version).

Technical Specifications

		EM 4	EM 8	EM 12	EM 20	EM 28	EM 40
Nominal capacity (m ³ /h)	50 Hz	4	8.5	12.5	18	28	42
	60 Hz	4.8	10	15	21	33	51
Ultimate pressure (abs) (mbar)	EM	2	2	2	2	2	2
	EM/B*	20	20	20	20	20	20
Motor power (kW)	50 Hz ~ 3	0.12	0.25	0.37	0.55	0.75	1.10
	50 Hz ~ 1	0.12	0.25	0.37	0.55	1.10	1.40
	60 Hz ~ 3	0.15	0.30	0.44	0.66	0.90	1.30
	60 Hz ~ 1	0.12	0.25	0.44	0.66	1.30	1.40
Motor speed (min ⁻¹)	50 Hz	3000	3000	3000	3000	3000	3000
	60 Hz	3600	3600	3600	3600	3600	3600
Dimensions (mm) (l x h x w)	50 Hz ~ 3	236x139x110	302x137x161	281x190x214	298x190x221	332x224x266	415x224x266
Total weight (kg)	50 Hz ~ 3	5.4	11.4	13	17	26	30

* Constant high pressure operating model.

Ox Series



Rough Vacuum Pumps

Ox pumps are used in food packaging installations where Oxygen gas is used during the packaging process. The use of materials that are compatible with the pumped gas as well as

the use of special synthetic oil allow these pumps to handle gases with high concentration of Oxygen assuring efficient performance and safety level during the process.

Technical Specifications

		Nominal capacity (m ³ /h)	Ultimate pressure (abs) (mbar)
PVL 15 Ox	50 Hz	18	0.5
	60 Hz	21	0.5
EU 45 Ox	50 Hz	48	0.5
	60 Hz	58	0.5
EU 65 Ox	50 Hz	69	0.5
	60 Hz	83	0.5
EU 105 Ox	50 Hz	105	0.5
	60 Hz	126	0.5
EU 160 Ox	50 Hz	152	0.5
	60 Hz	182	0.5
EU 205 Ox	50 Hz	207	0.5
	60 Hz	248	0.5
EU 300 Ox	50 Hz	300	0.5
	60 Hz	360	0.5
PVL 401 Ox	50 Hz	417	0.5
	60 Hz	500	0.5
PVL 541 Ox	50 Hz	553	0.5
	60 Hz	663	0.5
EU 650 Ox	50 Hz	660	0.5
	60 Hz	792	0.5
EU 1000 Ox	50 Hz	1033	0.5
	60 Hz	1239	0.5

SINGLE STAGE ROTARY VANE PUMPS

► PVL/EU Series



Agilent makes use of advanced engineering techniques onto CNC machines. Within Agilent vacuum pumps high quality materials and economical features match together to achieve: High pumping speed in a range of absolute vacuum - between 850 and 0,5 mbar - Low noise level - No pollution - Air-cooled - Rugged construction - Easy to service.

The vacuum pumps PVL/EU series are single-stage oil lubricated rotary vane vacuum pumps with oil recirculation system. They are used for the suction of air also in presence of water vapour and for continuous industrial use. Two different versions are available, depending on the application vacuum range. According to Pneurop 6602, the whole range extends from 18 m³/h to 1,239 m³/h nominal capacity.

Technical Specifications

		PVL 15	PVL 35	EU 45	EU 65	EU 105	EU 160
Nominal capacity (m³/h)	50 Hz	18	35	48	69	105	152
	60 Hz	21	42	58	83	126	182
Ultimate pressure (abs) (mbar)	PVL - EU	0.5	0.5	0.5	0.5	0.5	0.5
	PVL/B* - EU/B*	20	20	10	10	10	10
Motor power (kW)	50 Hz ~ 3	0.55	0.75	1.10	1.50	2.20	3.00
	50 Hz ~ 1	0.75	1.10	1.50	2.20	–	–
	60 Hz ~ 3	0.75	1.10	1.50	2.20	3.00	4.00
	60 Hz ~ 1	0.75	1.10	1.50	2.20	–	–
Motor speed (min⁻¹)	50 Hz	1500	1500	1500	1500	1500	1500
	60 Hz	1800	1800	1800	1800	1800	1800
Total weight (kg)	50 Hz ~ 3	25	38	52	60	82	104
	50 Hz ~ 1	27	42.5	56	66	–	–
	60 Hz ~ 3	26	40	54	65	86	110
	60 Hz ~ 1	27	42.5	56	66	–	–

		EU 205	EU 300	PVL 401	PVL 541	EU 650	EU 1000
Nominal capacity (m³/h)	50 Hz	207	300	417	553	660	1033
	60 Hz	248	360	500	663	792	1239
Ultimate pressure (abs) (mbar)	PVL - EU	0.5	0.5	0.5	0.5	0.5	0.5
	PVL/B* - EU/B*	10	10	10	10	–	10
Motor power (kW)	50 Hz ~ 3	4.0	5.5	7.5	11.0	15.0	22.0
	60 Hz ~ 3	5.5	7.5	11.0	15.0	18.5	30.0
Motor speed (min⁻¹)	50 Hz	1500	1500	1500	1500	1000	1000
	60 Hz	1800	1800	1800	1800	1200	1200
Total weight (kg)	50 Hz	161	188	305	330	580	862
	60 Hz	171	192	337	354	620	922

* Constant high pressure operating model.

▶ **Ex Series**



Rough Vacuum Pumps

Agilent has developed a range of vacuum pumps meeting the 94/9/EC standards, certified for ATEX zone 1 internal/external and temperature class T3 (200 °C), in answer to the

frequent requests for pumps capable of operating in hazardous environments.

Technical Specifications

		Nominal capacity (m ³ /h)	Ultimate pressure (abs) (mbar)
EU 45 Ex	50 Hz	50	0.5
	60 Hz	60	0.5
EU 65 Ex	50 Hz	69	0.5
	60 Hz	83	0.5
EU 105 Ex	50 Hz	105	0.5
	60 Hz	126	0.5
EU 160 Ex	50 Hz	152	0.5
	60 Hz	182	0.5
EU 300 Ex	50 Hz	300	0.5
	60 Hz	360	0.5

DUAL STAGE OIL LUBRICATED ROTARY VANE PUMPS

► DS-Series and PHV-K Series



Thanks to a very simple and highly reliable design, these field proven rotary vane pumps provide excellent vacuum performance. Agilent's quality and manufacturing standards

ensure that the Rotary Vane Pumps provide high pumping stability for light gases, low noise, minimal oil backstreaming, and a long operating life.

Technical Specifications

		DS 102	DS 202	DS 302	DS 402	DS 602	PHV 50K	PHV 75K
Nominal capacity (m ³ /h)	50 Hz	5.7	9.6	14.22	20.52	30.24	50	75
	60 Hz	6.84	12	17.1	24.6	36.3	60	90
Ultimate pressure (abs) (mbar)	Gas ballast closed	2x10 ⁻³	2x10 ⁻³	2x10 ⁻³	2x10 ⁻³	2x10 ⁻³	1x10 ⁻³	1x10 ⁻³
	Gas ballast pos.1	2x10 ⁻²	2x10 ⁻²	2x10 ⁻²	1x10 ⁻²	1x10 ⁻²	7x10 ⁻³	7x10 ⁻³
Motor power (kW)	50 Hz	0.45	0.45	0.45	0.75	0.75	1.50	2.20
	60 Hz	0.55	0.55	0.55	0.90	0.90	1.50	2.20
Motor speed (min ⁻¹)	50 Hz	1500	1500	1500	1500	1500	1500	1500
	60 Hz	1800	1800	1800	1800	1800	1800	1800
Total weight (kg)		22	25	25	35	35	68	84

► **DRY Series**



Rough Vacuum Pumps

Claw type pumps from the DRY series have been designed for those applications where the handled medium must remain contaminant free during the process.

The absence of wear parts in these pumps offers considerable savings in maintenance and associated down time.

Technical Specifications

		DRY 100	DRY 300
Nominal capacity (m ³ /h)	50 Hz	100	300
	60 Hz	120	360
Ultimate pressure (abs)* (mbar)		150	200
Motor power (kW)	50 Hz	2.2	5.5
	60 Hz	2.2	7.5
Motor speed (min ⁻¹)	50 Hz	3000	3000
	60 Hz	3600	3600
Noise level (dB(A))	50 Hz	78	80
	60 Hz	82	84
Total weight (kg)	50 Hz	100	215
	60 Hz	100	219

* Continuous operation.

ROOTS VACUUM PUMPS WITH BYPASS VALVE

▶ HV/BP Series



Roots vacuum pumps series HV/BP complete with bypass valve are mainly used coupled to our lubricated vacuum pumps to speed up pumping down times and to achieve vacuum level up to 0.01 mbar abs.

Bypass valve allows to start the Roots pump at the same time as the backing vacuum pump, protecting the Roots pump from any operation at high pressure.

Technical Specifications

		GMa 11.3 HV/BP	GMa 11.4 HV/BP	GMa 12.5 HV/BP	GMa 12.6 HV/BP	GMa 13.f7 HV/BP	GMa 13.8 HV/BP
Nominal capacity (m³/h)	50 Hz	500	730	1000	1400	2000	2840
	60 Hz	600	880	1200	1700	2420	3420
Ultimate pressure (abs)* (mbar)		0.02	0.02	0.02	0.02	0.02	0.02
Motor power (kW)	50 Hz	1.5	2.2	3.0	4.0	5.5	7.5
	60 Hz	2.2	3.0	4.0	5.5	7.5	11.0
Motor speed (min⁻¹)	50 Hz	3000	3000	3000	3000	3000	3000
	60 Hz	3600	3600	3600	3600	3600	3600
Noise level (dB(A))	50 Hz	71	71	72	72	75	75
	60 Hz	72	72	73	73	76	76
Weight (single phase/3-ph.) (kg)	50 Hz	178	184	232	295	387	513
	60 Hz	184	189	246	317	410	526

* Final vacuum is the vacuum achieved by coupling a Roots pump to a "Agilent" manufactured vacuum pump.

▶ HV Series



Rough Vacuum Pumps

Vacuum blowers series HV have been designed for conveying air and neutral gases and are especially used in industrial high vacuum technology. With a total of 19 sizes, the blowers

cover a theoretical nominal intake volume flow from 180 m³/h to 97,000 m³/h and pressure ranges 10⁻³ mbar abs up to approx. 200 mbar abs.

Technical Specifications

	Theoretical suction volume (m ³ /h)		Max. admissible diff. pressure for motor power (mbar)	Motor power (kW)	Speed (1/min)
GMa/GLa 10.0 HV	50 Hz	180	130	0.75	3000
	60 Hz	250	130	0.75	3600
GMa/GLa 10.1 HV	50 Hz	250	140	1.10	3000
	60 Hz	300	140	1.10	3600
GMa/GLa 10.2 HV	50 Hz	365	130	1.50	3000
	60 Hz	450	130	1.50	3600
GMa/GLa 11.3 HV	50 Hz	500	140	2.20	3000
	60 Hz	600	140	2.20	3600
GMa/GLa 11.4 HV	50 Hz	750	130	3.00	3000
	60 Hz	900	130	3.00	3600
GMa/GLa 12.5 HV	50 Hz	1000	130	4.00	3000
	60 Hz	1200	130	4.00	3600
GMa/GLa 12.6 HV	50 Hz	1430	130	5.50	3000
	60 Hz	1700	130	5.50	3600
GMa/GLa 13.f7 HV	50 Hz	2000	110	7.50	3000
	60 Hz	2400	110	7.50	3600
GMa/GLa 13.8 HV	50 Hz	2900	100	11.00	3000
	60 Hz	3450	100	11.00	3600
GMa/GLa 14.9 HV	50 Hz	3900	80	11.00	3000
	60 Hz	4700	80	11.00	3600
GMa/GLa 15.10 HV	50 Hz	5600	80	15.00	3000
	60 Hz	6700	80	15.00	3600
GMa/GLa 15.11 HV	50 Hz	7500	80	18.50	3000
	60 Hz	9000	80	18.50	3600
GMa/GLa 16.f13 HV	50 Hz	8150	75	18.50	1500
	60 Hz	9800	75	18.50	1800
GMa/GLa 16.13 HV	50 Hz	9750	75	22.00	1500
	60 Hz	11700	75	22.00	1800
GMa/GLa 17.15 HV	50 Hz	16000	60	30.00	1500
	60 Hz	18825	60	30.00	1800

COMPACT VACUUM GROUPS

▶ HV Series

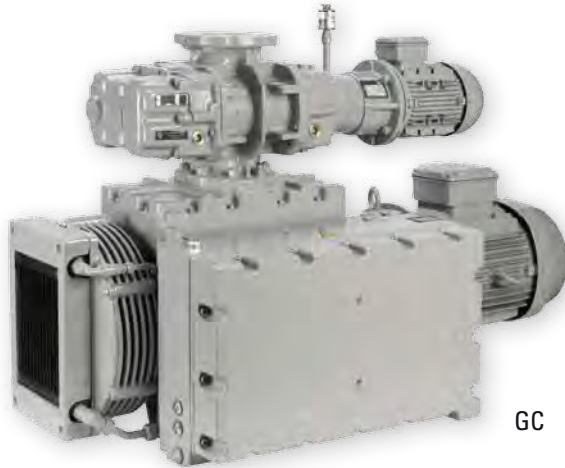

GC



GC-BP

Given the proven performance of our PVL401/PVL541 vacuum pumps and the HV series of Roots-type pumps, we have designed pumping groups that conveniently combine the benefits of both in high performance compact packages. The new GC packages provide the following significant benefits: Integral pipe-work allowing easier installation - Max. ultimate

vacuum 0.02 mbar abs. - max. capacity 1,700 m³/h. - Energy savings resulting from low motor rating - Compact footprints - Much reduced operating and maintenance costs. The GC vacuum packages can be further enhanced with accessories such as electrical panels to EC standards, process control options, inlet filters.

Technical Specifications

Pump type		GC 11.3-401	GC 11.4-541	GC 12.5-401	GC 12.6-541
		Roots pump GMa11.3HV	Roots pump GMa11.4HV	Roots pump GMa12.5HV	Roots pump GMa12.6HV
	Vane vacuum pump	PVL401	PVL541	PVL401	PVL541
Effective capacity at 1 mbar (m ³ /h)	50 Hz	452	655	860	1200
	60 Hz	542	786	1030	1440
Ultimate pressure (mbar)		0.02	0.02	0.02	0.02
Motor power (kW)	50 Hz	9.7	14.0	11.5	16.5
	60 Hz	13.2	18.0	15.0	20.5
Noise level (dB(A))	50 Hz	79	79	79	80
	60 Hz	80	80	80	81
Weight (kg)	50 Hz	435	505	535	610
	60 Hz	474	537	589	642

Pump type		GC 12.5BP-401	GC 12.6BP-541
		Roots pump GMa12.5HV/BP	Roots pump GMa12.6HV/BP
	Vane vacuum pump	PVL401	PVL541
Effective capacity at 1 mbar (m ³ /h)	50 Hz	840	1200
	60 Hz	1008	1440
Ultimate pressure (mbar)		0.02	0.02
Motor power (kW)	50 Hz	10.5	15.0
	60 Hz	15.0	20.5
Noise level (dB(A))	50 Hz	79	80
	60 Hz	80	81
Weight (kg)	50 Hz	542	630
	60 Hz	588	676

► **CM-ATEX Series**

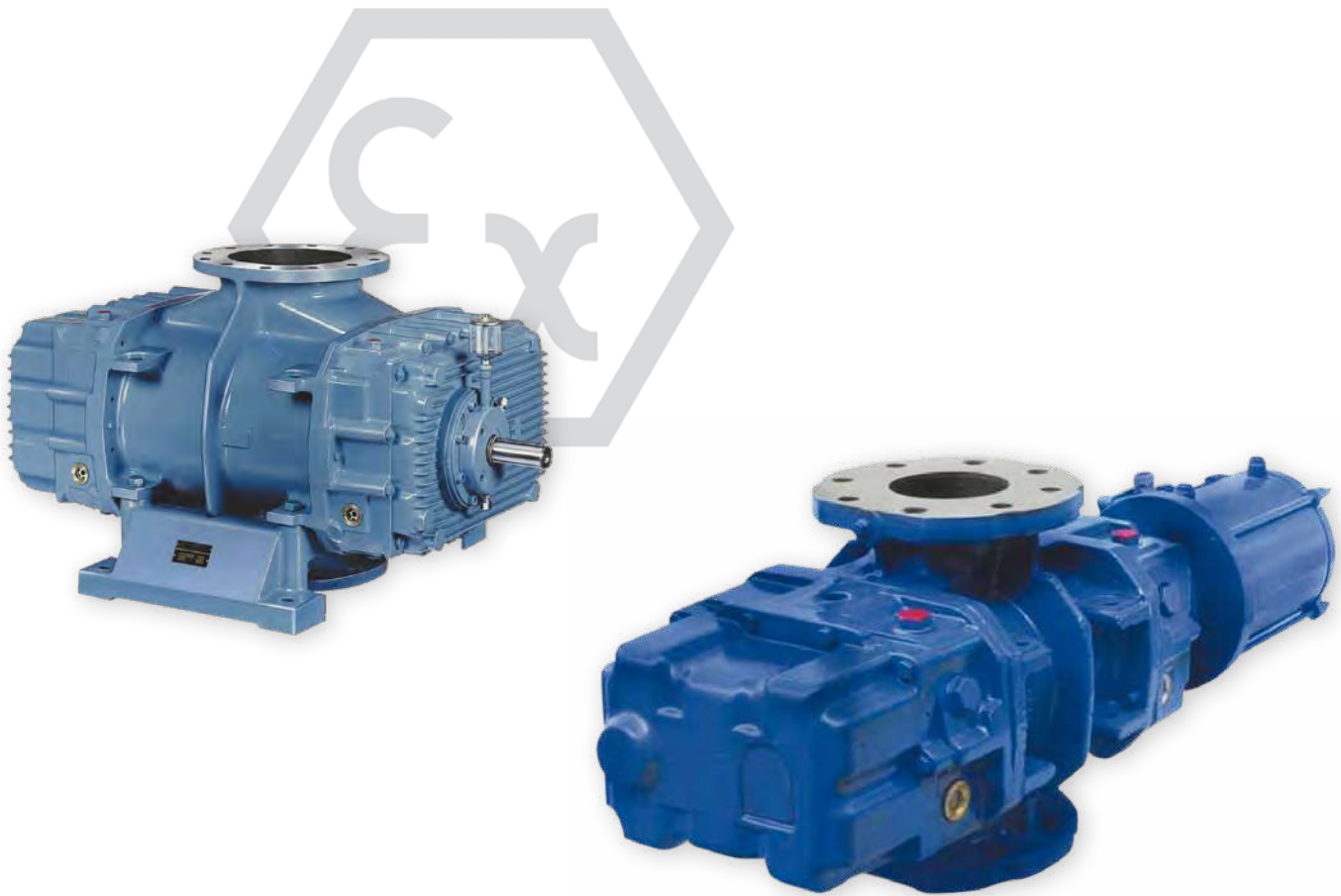

Rough Vacuum
Pumps

Blowers HV series and CM series (fitted with canned motor), have been approved according to 94/9/EC standards, certified

for ATEX Zone 0 (internal) temperature class T3 (200 °C) and Zone 1 (external) for temperature class T4 (135 °C).

CUSTOMIZED VACUUM SYSTEMS

► Pumping Systems



Vacuum groups are systems designed for customers which need to couple single stage or two-stage vane vacuum pumps to Roots pumps.

This solution allows to get large capacity related to very high ultimate pressure (up to 10^{-5} mbar) in relatively limited room.

Those systems are usually used for degassing process, heat treatments, drying systems, freeze-drying process, closed chamber pumping down, etc.

The group characteristics are defined depending on customer requirements.

► **MEDISYSTEM Series**



Rough Vacuum Pumps

Thanks to our experience developed in over forty years of vacuum pumps manufacturing, we have designed central vacuum systems series MEDISYSTEM. Manufactured in observance of EN ISO 7396-1 standards, these systems meet the requirements of all those medical structures, such as hospitals, clinics, nursing homes, analysis laboratories, etc. MEDISYSTEM groups are mainly formed by: three pumps systems able to guarantee the continuity of operation also in

case of emergency - vacuum tank fitted with vacuum switches - control panel, with 'touch-screen' system to check and schedule the complete group - antibacterial filter group with support and bypass system according to EN ISO 7396-1 standards - base-plate for all the components. MEDISYSTEM can be supplied as turnkey systems or as single component for the integration of already existing groups.

Technical Specifications

		CTV 500-15/H CTV 500-15B/H	CTV 500-45/H CTV 500-45B/H	CTV 500-65/H CTV 500-65B/H
Tank (l)		500	500	500
Nominal capacity (m³/h)	50 Hz	3x18	3x48	3x69
	60 Hz	3x21	3x58	3x83
Ultimate pressure (abs) (mbar)		0.5 (20)	0.5 (10)	0.5 (10)
Motor power (kW)	50 Hz ~ 3	3x0.55	3x1.1	3x1.5
	50 Hz ~ 1	3x0.75	3x1.5	3x2.2
	60 Hz ~ 3	3x0.75	3x1.5	3x2.2
	60 Hz ~ 1	3x0.75	3x1.5	3x2.2
Dimensions (mm) (l x h x w)	50 Hz ~ 3	1425x2322x912	1425x2322x912	1425x2322x912

		CTV 900-105 CTV 900-105BB/H	CTV 900-160/H CTV 900-160B/H	CTV 900-300/H CTV 900-300B/H
Tank (l)		900	900	900
Nominal capacity (m³/h)	50 Hz	3x105	3x152	3x300
	60 Hz	3x126	3x182	3x360
Ultimate pressure (abs) (mbar)		0.5 (10)	0.5 (20)	0.5 (10)
Motor power (kW)	50 Hz ~ 3	3x2.2	3x3	3x5.5
	50 Hz ~ 1	-	-	-
	60 Hz ~ 3	3x3.0	3x4	3x7.5
	60 Hz ~ 1	-	-	-
Dimensions (mm) (l x h x w)	50 Hz ~ 3	2413x2433x1123	2413x2433x1123	2413x2433x1123

CENTRAL VACUUM SYSTEMS

▶ CSZ/CDZ Series



Agilent offers a wide range of central vacuum systems including vessel and either one or two vacuum pumps. Our central vacuum systems are offered with horizontal or

vertical vessel, to maximize floor space. Customized central vacuum systems having different characteristics than those shown on the standard catalogue are available on request.

Technical Specifications

		Nominal capacity (m ³ /h)	Ultimate pressure (abs) (mbar)	Tank (l)
CSZ100-15(/B)	50 Hz	1x18	0.5 (20)	100
	60 Hz	1x21	0.5 (20)	100
CSZ100-35(/B)	50 Hz	1x35	0.5 (20)	100
	60 Hz	1x42	0.5 (20)	100
CSZ300-45(/B)	50 Hz	1x48	0.5 (10)	300
	60 Hz	1x58	0.5 (10)	300
CSZ300-65(/B)	50 Hz	1x69	0.5 (10)	300
	60 Hz	1x83	0.5 (10)	300
CSZ500-105(/B)	50 Hz	1x105	0.5 (10)	500
	60 Hz	1x126	0.5 (10)	500
CSZ500-160(/B)	50 Hz	1x152	0.5 (10)	500
	60 Hz	1x182	0.5 (10)	500
CSZ500-205(/B)	50 Hz	1x207	0.5 (10)	500
	60 Hz	1x248	0.5 (10)	500
CSZ500-300(/B)	50 Hz	1x300	0.5 (10)	500
	60 Hz	1x360	0.5 (10)	500

ROUGH VACUUM PUMPS



Technical Specifications

		Nominal capacity (m ³ /h)	Ultimate pressure (abs) (mbar)	Tank (l)
CDZ300-15(/B)	50 Hz	2x18	0.5 (20)	300
	60 Hz	2x21	0.5 (20)	300
CDZ300-35(/B)	50 Hz	2x35	0.5 (20)	300
	60 Hz	2x42	0.5 (20)	300
CDZ500-45(/B)	50 Hz	2x48	0.5 (10)	500
	60 Hz	2x58	0.5 (10)	500
CDZ500-65(/B)	50 Hz	2x69	0.5 (10)	500
	60 Hz	2x83	0.5 (10)	500
CDZ500-105(/B)	50 Hz	2x105	0.5 (10)	500
	60 Hz	2x126	0.5 (10)	500
CDZ500-160(/B)	50 Hz	2x152	0.5 (10)	500
	60 Hz	2x182	0.5 (10)	500
CDZ900-205(/B)	50 Hz	2x207	0.5 (10)	900
	60 Hz	2x248	0.5 (10)	900
CDZ900-300(/B)	50 Hz	2x300	0.5 (10)	900
	60 Hz	2x360	0.5 (10)	900

ACCESSORIES

▶ L Series



LUBRICANTS - We are able to offer a wide range of mineral and synthetic oils which allow the use of our vacuum pumps in several fields, from food to chemical one.

▶ KM Series



SERVICE KITS - Agilent offers service kits with all the necessary spare parts. Routine and major service kits are available to allow you to maintain the pumps.

▶ F Series



AIR FILTERS - Agilent dust filters are vacuum tight. Their housing is made of printed steel and their filtering cartridge is made of treated paper with 7 micron filtration power. They can be supplied with 60 micron stainless steel cartridge.

▶ FSC Series



FILTER WATER TRAP - The filter water trap is recommended for those applications where the pump sucks small quantity of liquid/s.

ROUGH VACUUM PUMPS

▶ CMV Series



MEDICAL FILTERS - Antibacterial filters series CMV ensure high filtration power able to avoid virus and bacteria propagation to environment. The filter elements have an efficiency $\geq 99,999\%$.

▶ Foreline Roughing Traps

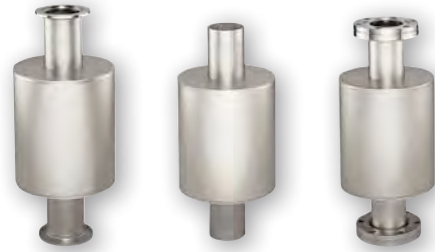

Agilent's new traps are designed to prevent the backstreaming of mechanical pump fluids. Copper and stainless steel gauze inserts are designed to reduce oil backstreaming.

Rough Vacuum Pumps

▶ Exhaust Filters /TMF Series



OIL MIST TRAPS - Oil mist traps get rid of the oil mist easily by using a double filtering system in order to get the working environment free from polluting agents.



HIGH CAPACITY ROTARY VANE PUMPS AND ROOTS PUMPING SYSTEMS

- 2-3 MS-Series Rotary Vane Pumps
- 4-5 RPS-Series Roots Pumping Systems
- 6-7 Typical Applications
- 8-20 Pump Models



Agilent Technologies

MS-SERIES ROTARY VANE PUMPS FEATURES AND BENEFITS

Agilent: a complete solution provider for the industrial vacuum equipment

Agilent MS-Series high capacity mono stage oil lubricated rotary vane pumps, from 95 to 680 m³/h.

- MS-Series pumps are robust, easy to install, and are ideal for use in many different applications
- Because of their compact size, MS-Series pumps can easily replace other pumps of equivalent pumping speed

**Industry leading vacuum performance;
more than 20,000 RV pumps in operation!**

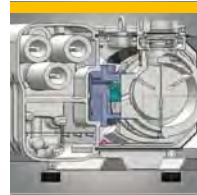

Shorter Cycle Times

- Smooth continuous operation, from atmospheric to base pressure
- High pumping speed even at low pressure

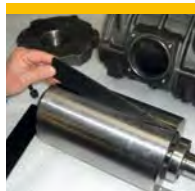

Highly Robust for Stringent Applications

- Steel rotor
- Cast iron stator and cover
- Special design carbon fiber vanes
- Viton seals
- Gas ballast valve, for pumping high water vapor content
- Anti-suckback isolation inlet valve eliminates oil backstreaming and holds vacuum in case of power loss



Environmentally Friendly

- A demister system limits oil exhaust over the entire range of working pressures
- Floating valve for oil recovery

HIGH CAPACITY MS-RPS SERIES



Industry Leading Vacuum Performance

- Pump design allows lowest base partial pressure: 8×10^{-2} mbar (6×10^{-2} Torr)

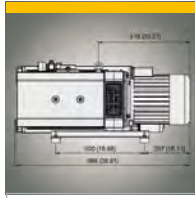

Compact and Easy to Install

- Air cooling
 - cover design optimizes cooling air channels
 - integrated heat exchanger carries excess heat away
- Smaller than pumps of equivalent pumping speed

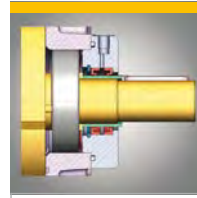

Highly Reliable

- Highly efficient oil circulation system ensures perfect lubrication and sealing in all critical areas of the pump
- Low noise and vibration

High Capacity
MS-RPS Pumps



RPS-SERIES ROOTS PUMPS & PUMPING SYSTEMS (FEATURES AND BENEFITS)

RP-Series Roots Pumps

State-of-the-art, high performance Agilent Roots Pumps are ideal for use in demanding industrial applications.

RPS-Series Roots Pumping Systems

Agilent's RPS Systems combine the ruggedness and reliability of High Capacity MS-Series RVPs with wide range Roots Pumps.

More than 15,000 Roots Pumps in Operation!



Compact and Easy to Use

- Agilent Roots Pumps are simple to use and to install
- Air cooling

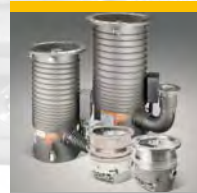

Designed for Optimum System Integration

- Ideal combination for roughing down and backing Diffusion Pumps, Turbomolecular Pumps, and other HV pumps
- Optional electronics for continuous operation and monitoring of Vacuum Systems



Clean

Ideal for use in applications demanding the highest levels of cleanliness:

- Special labyrinth seal prevents contamination
- A high capacity trap chamber captures condensation



VFD Roots

- Inverter driven Roots to improve performance and minimize power consumption
- Constant performance at different input frequencies

HIGH CAPACITY MS-RPS SERIES

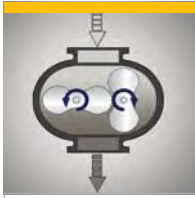

High Performance Roots Pumps

- Agilent Roots Pumps can withstand high mechanical loads reducing pumpdown cycles
- Lowest base pressure:
 5×10^{-3} mbar (4×10^{-3} Torr)

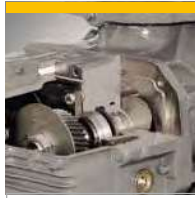

Rugged and Reliable

- Low noise and vibration, thanks to dynamically balanced rotors and precision ground gears
- Long maintenance intervals
- Air cooling



Popular Sizes Available

- Combining MS-Series RVPs (from 95 to 680 m³/h) and Roots Pumps (from 250 to 4000 m³/h) allows tailored solutions optimizing performances, cost and power consumption

Other combinations are available on request.

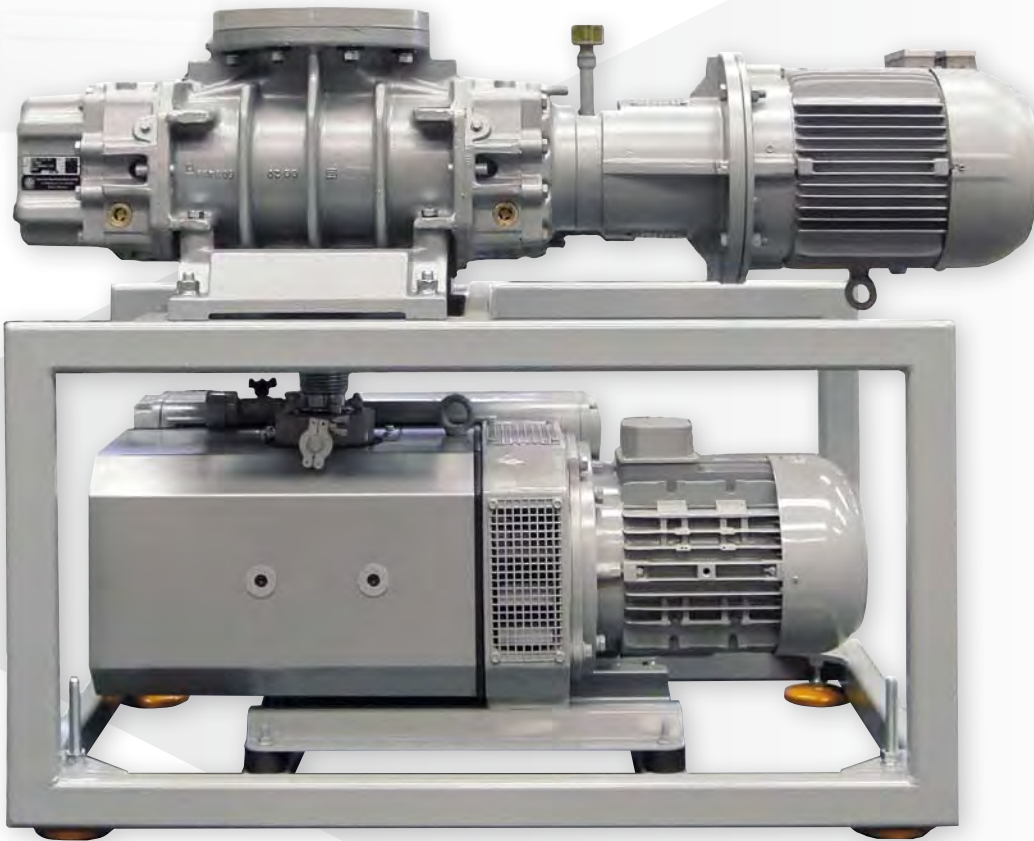

TYPICAL APPLICATIONS



Roughing and Backing High Vacuum Pumps

The new MS Pumps and RPS Systems are ideally suited for use in combination with Turbomolecular and Diffusion pumps or with HV pumps of any other manufacturer.

Agilent is a leading solution provider for the industrial high and medium vacuum marketplace.



Vacuum Coating Systems

The most common application where the RPS are used are coaters of different dimensions, from small ones used in research fields to the very large ones used in industrial applications, including for instance glass coaters or coaters where large automotive or aircraft parts are treated. The ability to offer large RV pumps, up to 680 m³/h and Roots pumps up to 4000 m³/h make the Agilent offer in this range particularly interesting and able to satisfy different needs.

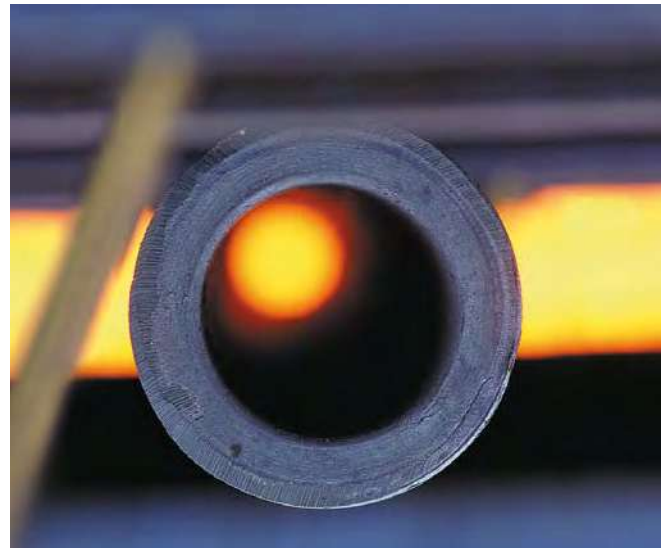

Metallurgy and Heat Treatment

In this field Agilent has offered so far a very large number of Diffusion pumps, with sizes ranging up to 35,000 l/s. The availability now to provide the full vacuum system up to the atmospheric pressure is rapidly bringing this offer to satisfy most of the users, who are particularly interested in rapid cycle times and the excellent overall reliability of the Agilent solution.

HIGH CAPACITY MS-RPS SERIES



Helium Leak Detection

When large volumes or short cycle times are required for a process involving leak detection, typically but not only using helium, the Agilent RV pumps alone or in combination with the Roots pumps are an ideal solution to reach the parameters necessary for industrial applications. Agilent is well aware of technical aspects of this technology having been a pioneer in leak detection for several decades.



Electron Beam Welding

EBW equipment requires the use of both High Vacuum Pumps, during generation and running of the welding beam, and Medium Vacuum Pumps for the rest of the process taking place in the chamber where the parts to be welded are positioned. Thanks to the introduction of the new Roots Pumping Systems, today Agilent is in a position to offer the entire vacuum system, as a single supply source in this important industry.



LNG

Liquefied Natural Gas (LNG) is natural gas converted to liquid form for ease of storage or transport. LNG must be kept cold to remain a liquid, independent of pressure. For this reason it must be stored in vacuum-jacketed, cryogenic tanks pressure vessels. These tanks may be at pressures anywhere from less than 50 kPa to over 1,700 kPa (7 psig to 250 psig). Agilent Roots Pumping Systems, in combination with Agilent Diffusion Pumps, are ideal to create vacuum in the annular space of the cryogenic tanks.

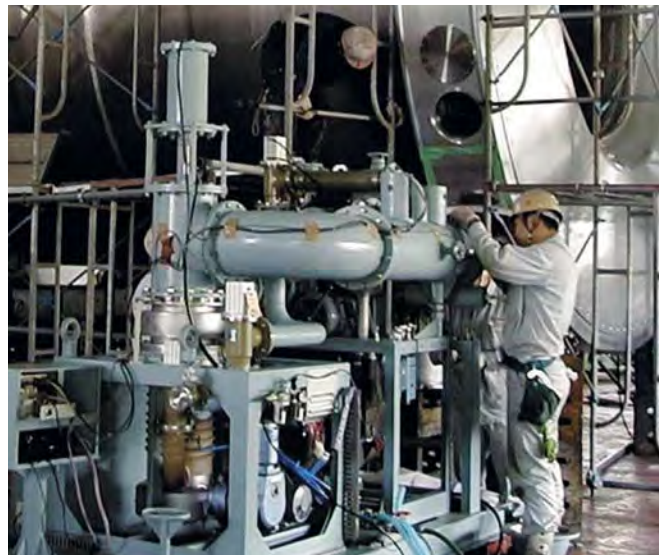

Other Industrial Applications

Agilent RV pumps and Roots Systems are suitable for use in many other applications, including lamps manufacturing, vacuum drying and degassing, gas recovery, packing industry, chemistry and process technology, PET processing, pharmaceutical industry, vacuum distillation, cryogenic vessel evacuation, and many others.

PUMP MODELS

▶ Agilent MS-101

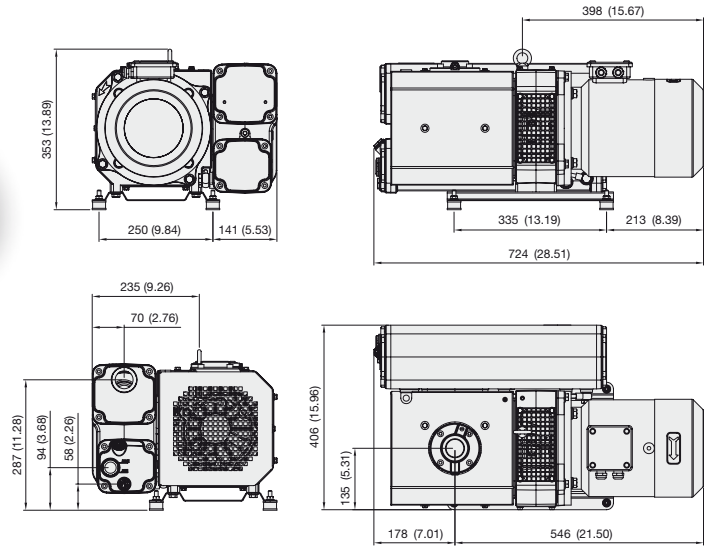

Dimensions: millimeters (inches)

Technical Specifications

Free air displacement	60 Hz: 130 m ³ /hr, 76 cfm 50 Hz: 110 m ³ /hr, 65 cfm
Pumping speed*	60 Hz: 109 m ³ /hr, 64 cfm 50 Hz: 95 m ³ /hr, 56 cfm
Ultimate partial pressure (with gas ballast closed)	≤ 0.1 mbar (≤ 8 × 10 ⁻² Torr)
Ultimate total pressure (with gas ballast open)	≤ 0.5 mbar (≤ 0.4 Torr)
Power	60 Hz: 3.0 kW (4.0 HP) 50 Hz: 2.2 kW (3.0 HP)
Electrical motor characteristics	IM B5 Δ230/Y400 V at 50 Hz IM B5 YY230/Y460 V at 60 Hz IM B5 Δ220/Y380 V at 60 Hz
Revolutions number	60 Hz: 1800 RPM 50 Hz: 1500 RPM
Water vapor tolerance	60 Hz/50 Hz: 40/30 mbar (30/23 Torr)
Water vapor capacity	60 Hz/50 Hz: 3/2.2 kg/h (3.3/2.4 qt/hr)
Noise level**	60 Hz/50 Hz: 68/66 dB(A)
Inlet port	1¼" gas / 1¼" NPT/ DN40KF using adapter flanges
Exhaust port	1¼" gas / 1¼" NPT
Oil	type MS-01, charge 3 liter (3.1 qt)
Working ambient temperature range	+12 +40 °C (+54 +105 F)
Storage temperature	-15 +70 °C (+5 +158 F)
Dimensions	60 Hz: 750 x 405 x 349 mm (20.5 x 15.9 x 13.7 in.) 50 Hz: 718 x 405 x 349 mm (28.3 x 15.9 x 13.7 in.)
Weight	
with 2.2 kW motor	85 kg (187 lbs)
with 3.0 kW motor	89 kg (196 lbs)
without motor	62 kg (137 lbs)

* According to PNEUROP 6602

** According to EN ISO 2151 (50/60 Hz)

HIGH CAPACITY MS-RPS SERIES

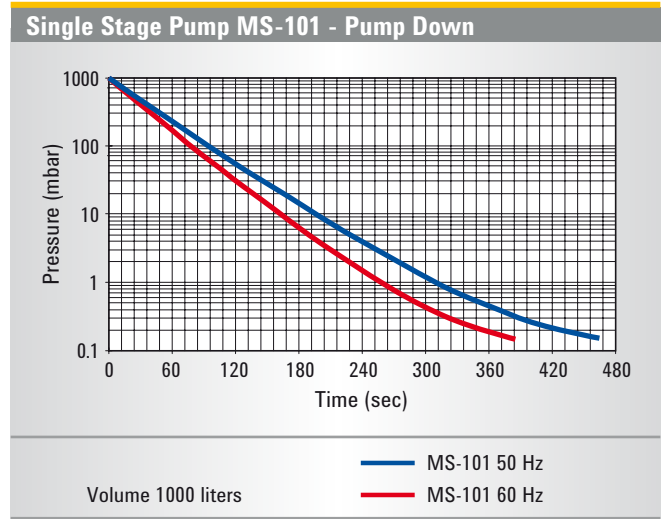
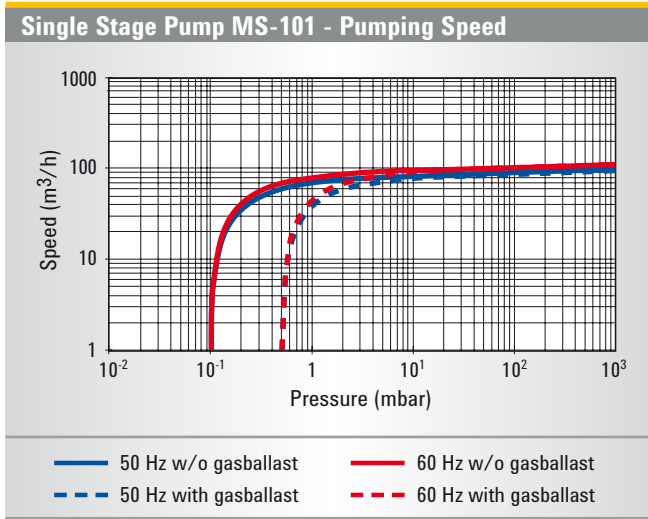

High Capacity MS-RPS Pumps

Ordering Information

High Capacity Rotary Vane Pumps *	Part Number
MS-101 2.2 kW Δ230/Y400 V, 50 Hz; IE2; inlet 1¼" gas	X3751-60019
MS-101 3.0 kW Δ230/Y400 V, 50 Hz; 460 V, 60 Hz; inlet 1¼" gas	X3751-64008
MS-101 3.0 kW Δ230/Y380 V, 60 Hz; IE2; inlet 1¼" gas	X3751-60026
MS-101 3.0 kW YY230/Y460 V, 60 Hz; IE2; inlet 1¼" NPT (US version)	X3751-60021

* Oil charge not included

Oil and Accessories	Part Number
MS-01 Oil charge for MS-101 (3 liters)	X3760-64001
Inlet air filter with polyester cartridge, for DN40 KF	X3751-60014
Inlet air filter with polyester cartridge, for 1¼" gas	X3751-60013
Inlet air filter with polyester cartridge, for 1¼" NPT	X3751-60030
Connection fitting kit, for DN40 KF	X3751-60016
Connection fitting kit, for for 1¼" gas	X3751-60015
Connection fitting kit, for 1¼" NPT	X3751-60031
Exhaust filter control pressure switch	9495077
1¼" gas to DN40 KF adapter	X3751-64009
1¼" NPT to DN40 KF adapter	X3751-64010

Spare Parts	Part Number
MS-101 minor spare part kit	X3751-60010
MS-101 major spare part kit	X3751-60011
MS-101 inlet air filter polyester cartridge	X3751-60017
MS-101 exhaust coalescent filter kit	X3751-60018

PUMP MODELS

▶ Agilent MS-301

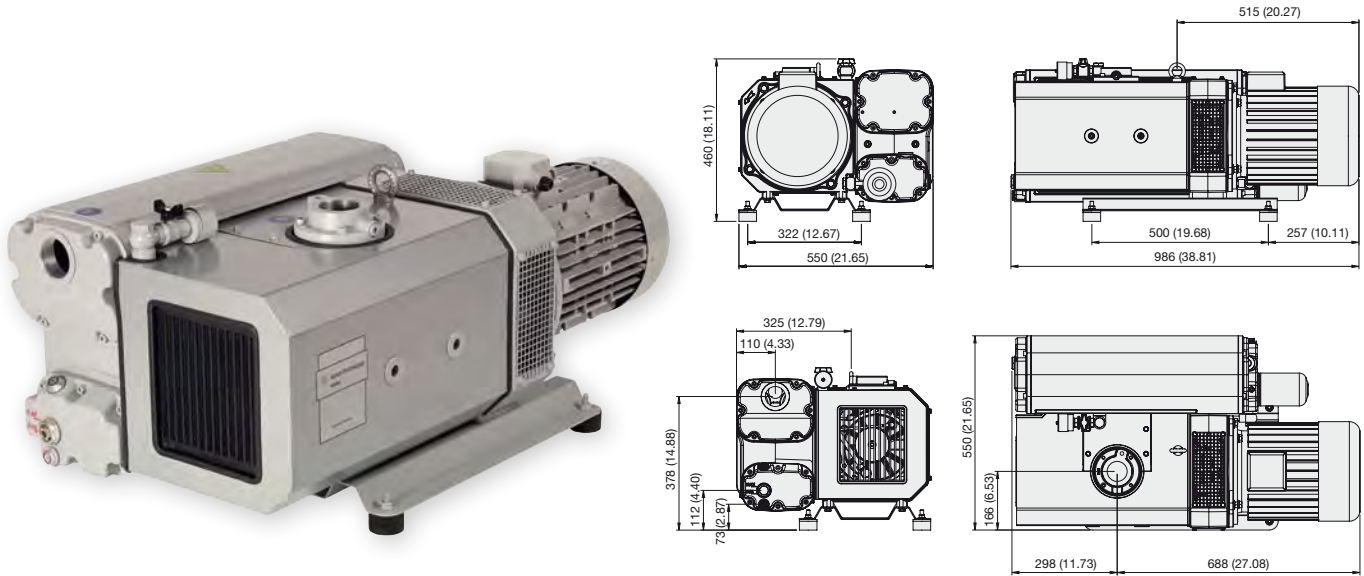

Dimensions: millimeters (inches)

Technical Specifications

Free air displacement	60 Hz: 350 m ³ /hr, 210 cfm 50 Hz: 290 m ³ /hr, 170 cfm
Pumping speed*	60 Hz: 290 m ³ /hr, 170 cfm 50 Hz: 250 m ³ /hr, 150 cfm
Ultimate partial pressure (with gas ballast closed)	≤ 8 × 10 ⁻² mbar (≤ 6 × 10 ⁻² Torr)
Ultimate total pressure (with gas ballast open)	≤ 0.5 mbar (≤ 0.37 Torr)
Power	60 Hz: 7.5 kW (10.0 HP) 50 Hz: 5.5 kW (7.4 HP)
Electrical motor characteristics	IM B5 Δ230/Y400 V at 50 Hz, Y460 V at 60 Hz IM B5 Δ400/Y690 V at 50 Hz, Δ460 V at 60 Hz IM B5 Δ220/Y380 V at 60 Hz IM B5 YY230/Y460 V at 60 Hz
Revolutions number	60 Hz: 1750 RPM 50 Hz: 1450 RPM
Water vapor tolerance	60 Hz/50 Hz: 40/30 mbar (30/23 Torr)
Water vapor capacity	60 Hz/50 Hz: 7/5 kg/h (7.7/5.5 qt/hr)
Noise level**	60 Hz/50 Hz: 76/72 dB(A)
Inlet port	Flange DN 63 ISO-K / 2" gas / 2" NPT
Exhaust port	2" gas / 2" NPT
Oil	type MS-01, charge 7 liter (7.4 qt)
Working ambient temperature range	+12 +40 °C (+54 +105 F)
Storage temperature	-20 +70 °C (+4 +158 F)
Dimensions	60 Hz: 1015 x 550 x 460 mm (40.3 x 21.6 x 18.1 in.) 50 Hz: 986 x 550 x 460 mm (38.8 x 21.6 x 18.1 in.)
Weight	
with 5.5 kW motor	188 kg (414 lbs)
with 7.5 kW motor	192 kg (423 lbs)
without motor	141 kg (310 lbs)

* According to PNEUROP 6602

** According to EN ISO 2151 (50/60 Hz)

HIGH CAPACITY MS-RPS SERIES

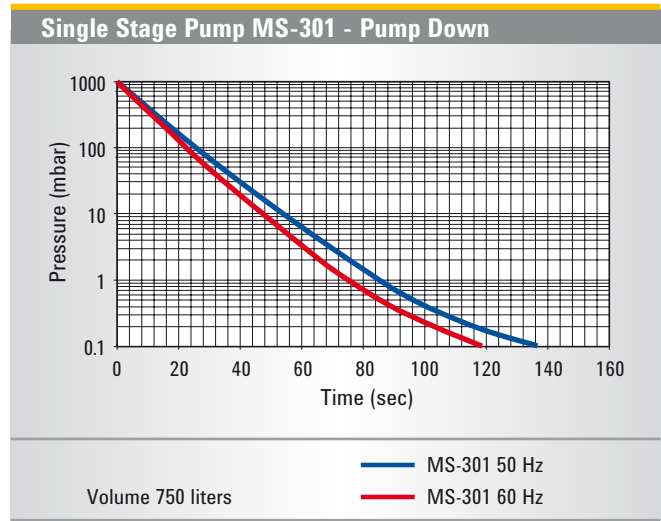
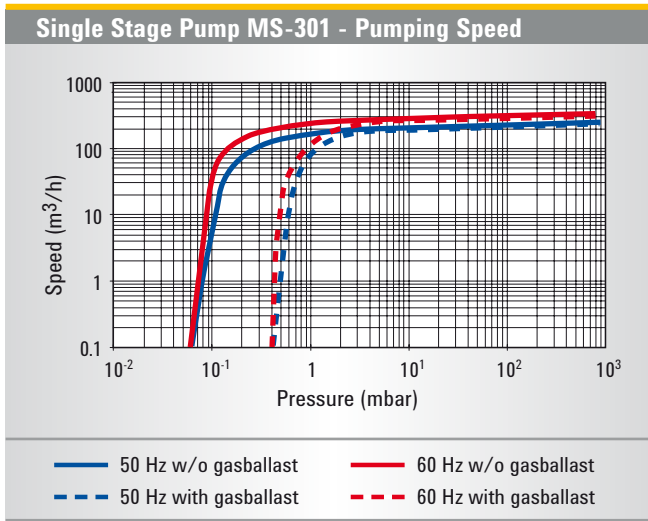

High Capacity MS-RPS Pumps

Ordering Information

High Capacity Rotary Vane Pumps *	Part Number
MS-301 5.5 kW, Δ230/Y400 V, 50 Hz; IE2; inlet 2" gas	X3752-64016
MS-301 5.5 kW, Δ230/Y400 V, 50 Hz; IE2; DN 63 ISO-K	X3752-64017
MS-301 5.5 kW, Δ400/Y690 V, 50 Hz; IE2; inlet 2" gas	X3752-64018
MS-301 5.5 kW, Δ400/Y690 V, 50 Hz; IE2; DN 63 ISO-K	X3752-64019
MS-301 7.5 kW, Δ230/Y400 V, 50 Hz - Y460 V 60 Hz; inlet 2" gas	X3752-64020
MS-301 7.5 kW, Δ230/Y400 V, 50 Hz - Y460 V 60 Hz; DN 63 ISO-K	X3752-64021
MS-301 7.5 kW, Δ230/Y380 V, 60 Hz; inlet 2" gas	X3752-64024
MS-301 7.5 kW, Δ230/Y380 V, 60 Hz; inlet DN 63 ISO-K	X3752-64025
MS-301 7.5 kW, YY230/Y460 V, 60Hz; inlet 2" NPT (US version)	X3752-64022
MS-301 7.5 kW, YY230/Y460 V, 60Hz; inlet DN 63 ISO-K (US version)	X3752-64023

* Oil charge not included

Oil and Accessories	Part Number
MS-01 Oil charge for MS-301 (7 liters)	X3760-64002
Inlet air filter with polyester cartridge, for 2" gas connection	9495059
Inlet air filter with polyester cartridge with DN 63 ISO-K flange	9495159
Connection fitting kit, for 2" gas connection	9495065
Connection fitting kit, for DN 63 ISO-K flange connection	9495165

Protective Accessories	Part Number
Pump thermal protection switch (to be ordered together with the pump)	9495076
Oil separator control pressure switch (to be ordered together with the pump)	9495077
MS-301 oil level protection switch (to be ordered together with the pump)	9495078

Spare Parts	Part Number
MS-301 minor spare part kit	9495020
MS-301 major spare part kit	9495021
Oil filter (type A)	9495070
MS-301 inlet air filter polyester cartridge	9495083
MS-301 exhaust coalescent filter kit	SR03706308

PUMP MODELS

▶ Agilent MS-631

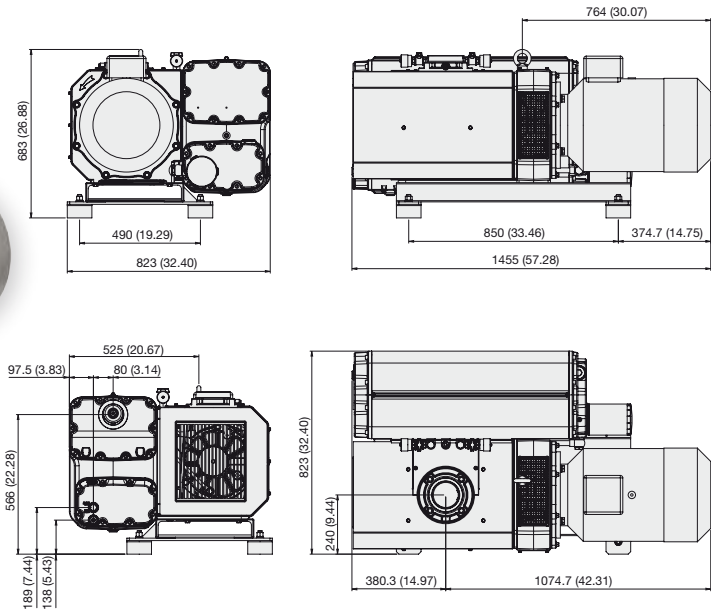

Dimensions: millimeters (inches)

Technical Specifications

Free air displacement	60 Hz: 790 m ³ /hr, 465 cfm 50 Hz: 660 m ³ /hr, 390 cfm
Pumping speed*	60 Hz: 680 m ³ /hr, 400 cfm 50 Hz: 590 m ³ /hr, 350 cfm
Ultimate partial pressure (with gas ballast closed)	≤ 8 x 10 ⁻² mbar (≤ 6 x 10 ⁻² Torr)
Ultimate total pressure (with gas ballast open)	≤ 0.5 mbar (≤ 0.37 Torr)
Power	60 Hz: 18.5 kW (24.8 HP) 50 Hz: 15 kW (20.1 HP)
Electrical motor characteristics	IM B5 Δ400/Y690 V at 50 Hz, Δ460 V at 60 Hz IM B5 Δ220/Y380 V at 60 Hz IM B5 YY230/Y460 V at 60 Hz
Revolutions number	60 Hz: 1200 RPM 50 Hz: 1000 RPM
Water vapor tolerance	60 Hz/50 Hz: 40/30 mbar (30/23 Torr)
Water vapor capacity	60 Hz/50 Hz: 30/20 kg/h (33.1/22.0 qt/hr)
Noise level**	60 Hz/50 Hz: 73/71 dB(A)
Inlet port	Flange DN 100 ISO-K / 4" gas / 4" NPT
Exhaust port	3" gas / 3" NPT
Oil	type MS-01, charge 22 liter (23.2 qt)
Working ambient temperature range	+12 +40 °C (+54 +105 F)
Storage temperature	-20 +70 °C (+4 +158 F)
Dimensions	60 Hz: 1480 x 823 x 683 mm (58.2 x 32.4 x 26.9 in.) 50 Hz: 1455 x 823 x 683 mm (57.3 x 32.4 x 26.9 in.)
Weight	
with 15.0 kW motor	582 kg (1283 lbs)
with 18.5 kW motor	612 kg (1349 lbs)
without motor	392 kg (864 lbs)

* According to PNEUROP 6602

** According to EN ISO 2151 (50/60 Hz)

HIGH CAPACITY MS-RPS SERIES

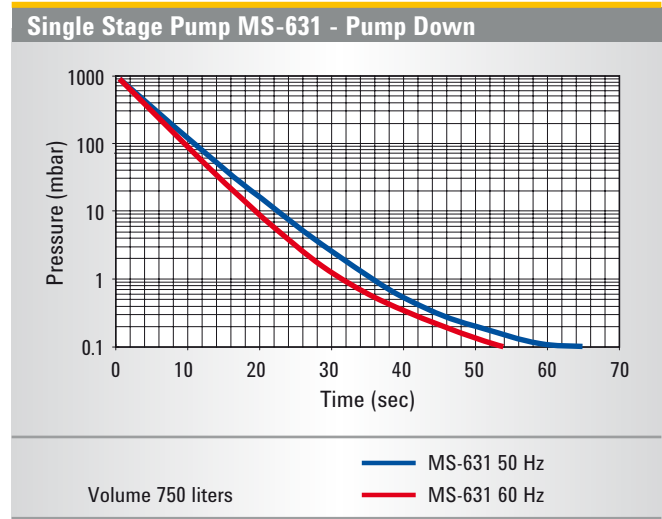
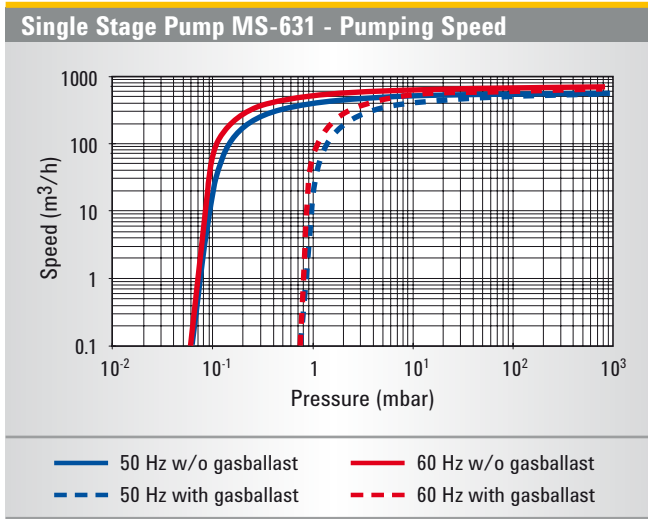

High Capacity
MS-RPS Pumps

Ordering Information

High Capacity Rotary Vane Pumps *	Part Number
MS-631 15.0 kW, Δ400/Y690 V, 50 Hz; IE2; inlet 4" gas	X3753-64073
MS-631 15.0 kW, Δ400/Y690 V, 50 Hz; IE2 DN 100 ISO-K	X3753-64074
MS-631 15.0 kW, Δ400/Y690 V, 50 Hz - Δ460 V, 60 Hz; inlet 4" gas	X3753-64075
MS-631 18.5 kW, Δ400/Y690 V, 50 Hz - Δ460 V, 60 Hz; DN 100 ISO-K	X3753-64076
MS-631 18.5 kW, Δ220/Y380 V, 60 Hz; IE2; inlet 4" gas	X3753-64079
MS-631 18.5 kW, Δ220/Y380 V, 60 Hz; IE2; DN 100 ISO-K	X3753-64080
MS-631 18.5 kW, YY230/Y460 V, 60 Hz; IE2; inlet 4" gas	X3753-64077
MS-631 18.5 kW, YY230/Y460 V, 60 Hz; IE2; DN 100 ISO-K	X3753-64078

* Oil charge not included

Oil and Accessories	Part Number
MS-01 Oil charge for MS-631 (22 liters)	X3760-64003
Inlet air filter with polyester cartridge, for 4" gas connection	9495062
Inlet air filter with polyester cartridge with DN 100 ISO-K flange	9495162
Connection fitting kit, for 4" gas connection	9495066
Connection fitting kit, for DN 100 ISO-K flange connection	9495166

Protective Accessories	Part Number
Pump thermal protection switch (to be ordered together with the pump)	9495076
Oil separator control pressure switch (to be ordered together with the pump)	9495077
MS-631 oil level protection switch (to be ordered together with the pump)	9495079

Spare Parts	Part Number
MS-631 minor spare part kit	9495087
MS-631 major spare part kit	9495088
Oil filter (type B)	9495090
MS-631 inlet air filter polyester cartridge	9495089
MS-631 exhaust coalescent filter kit	SR03706207

PUMP MODELS

▶ Agilent MS-631 FL (Frameless)



The Agilent MS-631 Frameless (FL) is a high capacity, single stage, oil lubricated rotary vane pump, that can be directly coupled to an Agilent Roots Pump (up to RP-3001 size) without the need of a frame.

The Roots Pump can be mounted directly on the MS-631 FL,

through an appropriate flange that can sustain the weight of the Roots Pump. The Roots Pump can be ordered separately. Please contact Agilent for technical specifications and ordering information.

The two pumps are shipped separately.

Applications

The rugged design, high performance and reliability, and compact size make the MS-631 FL ideal for demanding industrial applications such as thin film coatings, vacuum metallurgy, helium leak detection, and electron beam welding.

Key pump features

- Minimum footprint
- Easy to service
- Oil recirculation system
- Anti-suckback valve prevents system contamination
- Floating oil recovery valve
- Oil-level sight-glass allows quick visual check of pump status
- Carbon composite vanes extend pump life
- Air cooled

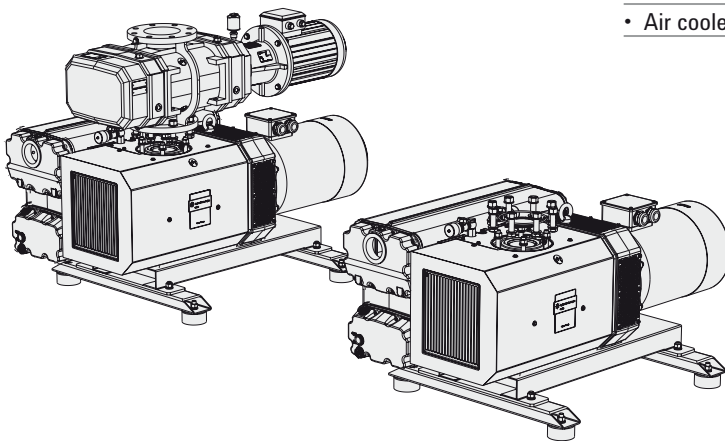

HIGH CAPACITY MS-RPS SERIES

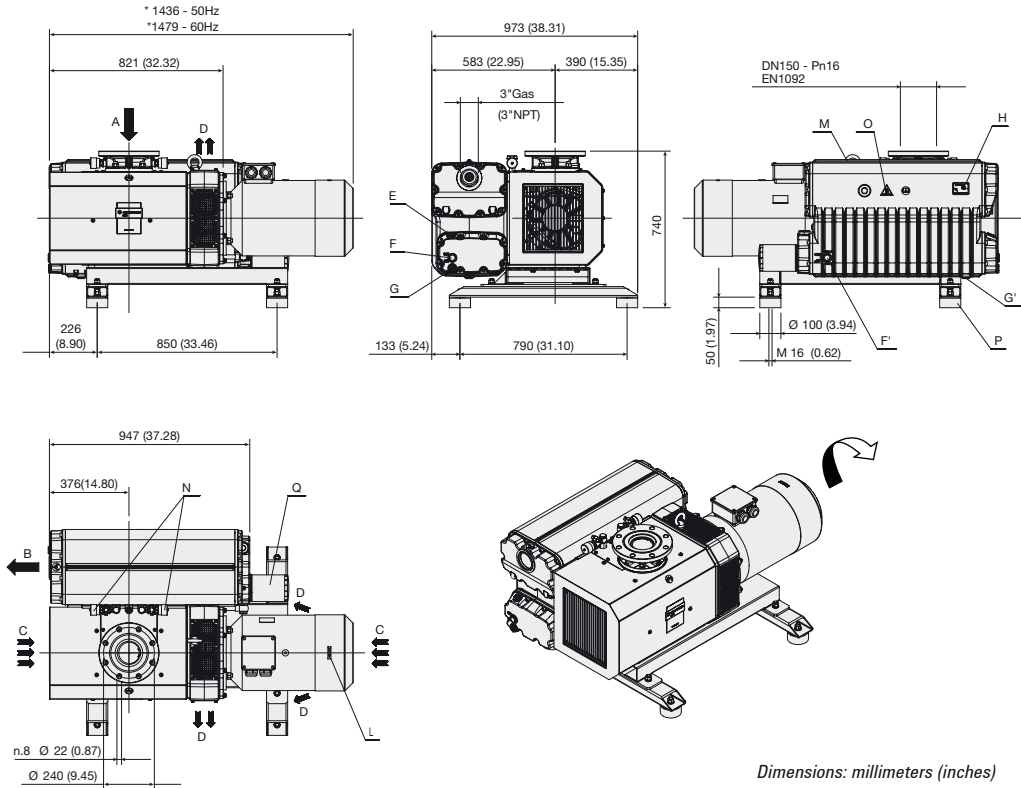

Technical Specifications

MS631FL can be directly coupled with RP-1401, RP-2001 and RP-3001.

Nominal speed*	660 m ³ (at 50 Hz) 790 m ³ (at 60 Hz)
Ultimate partial pressure (with gas ballast valve closed)*	≤ 8 x 10 ⁻² mbar (≤ 8 x 10 ⁻² Torr)
Ultimate total pressure (with gas ballast valve open)*	≤ 0.5 mbar (≤ 0.37 Torr)
Motor power/rotational speed** (3ph)	15 (1000 min-1) kW (rpm) at 50 Hz 18.5 (1200 min-1) kW (rpm) at 60 Hz
Electrical motor characteristics	IM B5 Δ400/Y690 V at 50 Hz, Δ460 V at 60 Hz IM B5 Δ220/Y380 V at 60 Hz IM B5 YY230/Y460 V at 60 Hz
Noise pressure level (without gas ballast valve)***	71 dB(A) at 50 Hz 73 dB(A) at 60 Hz
Water vapor tolerance	60 Hz / 50 Hz: 40/30 mbar (30/23 Torr)
Water vapor capacity	60 Hz / 50 Hz: 30/20 kg/h (33.1/22.0 qt/hr)
Oil capacity	min 19 l max 25 l nominal 22 l
Weight	
with 15.0 kW motor	591 kg (1301.79 lbs)
with 18.5 kW motor	643 kg (1416.33 lbs)
without motor	419 kg (922.93 lbs)
Operating temperature range	12 – 40 °C

* According to PNEURO P standard 6602

** Valid for temperatures up to 40 °C and altitudes lower than 1000 m

*** According to UNI EN ISO 2151 standard

PUMP MODELS

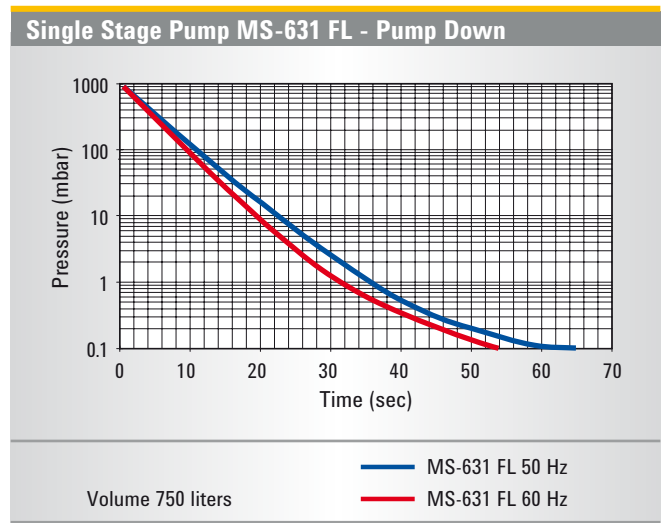
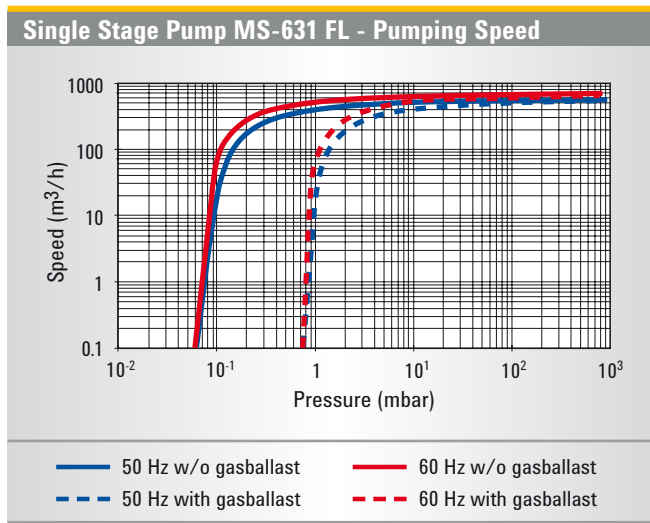

Ordering Information

High Capacity Rotary Vane Pumps *	Part Number
MS-631FL 15.0 kW, Δ400/Y690 V, 50 Hz; IE2; DN150 DIN2533	X3753-64000
MS-631FL 18.5 kW, Δ400/Y690 V, 50 Hz - Δ460 V, 60 Hz; DN150 DIN2533	X3753-64002
MS-631FL 18.5 kW, Δ220/Y380 V, 60 Hz; IE2; DN150 DIN2533	X3753-64006
MS-631FL 18.5 kW, YY230/Y460 V, 60 Hz; IE2; DN150 DIN2533	X3753-64004
Full Optional **	Part Number
MS-631FL 15.0 kW, Δ400/Y690 V, 50 Hz; IE2; DN150 DIN2533	X3753-64091
MS-631FL 18.5 kW, Δ400/Y690 V, 50 Hz - Δ460 V, 60 Hz; DN150 DIN2533	X3753-64092
MS-631FL 18.5 kW, Δ220/Y380 V, 60 Hz; IE2; DN150 DIN2533	X3753-64094
MS-631FL 18.5 kW, YY230/Y460 V, 60 Hz; IE2; DN150 DIN2533	X3753-64093
Oil and Spare Parts	Part Number
MS-01 oil 22 lt	X3760-64003
MS-631 minor spare part kit	9495087
MS-631 major spare part kit	9495088
Oil filter (Type B)	9495090
Frameless upgrade kit for standard MS-631	X3753-64089

* Oil charge not included

** Full optional version include:

- Pump thermal protection switch
- Exhaust filter control pressure switch
- Oil level protection switch

HIGH CAPACITY MS-RPS SERIES

RPS-1401 / MS-631 FL System

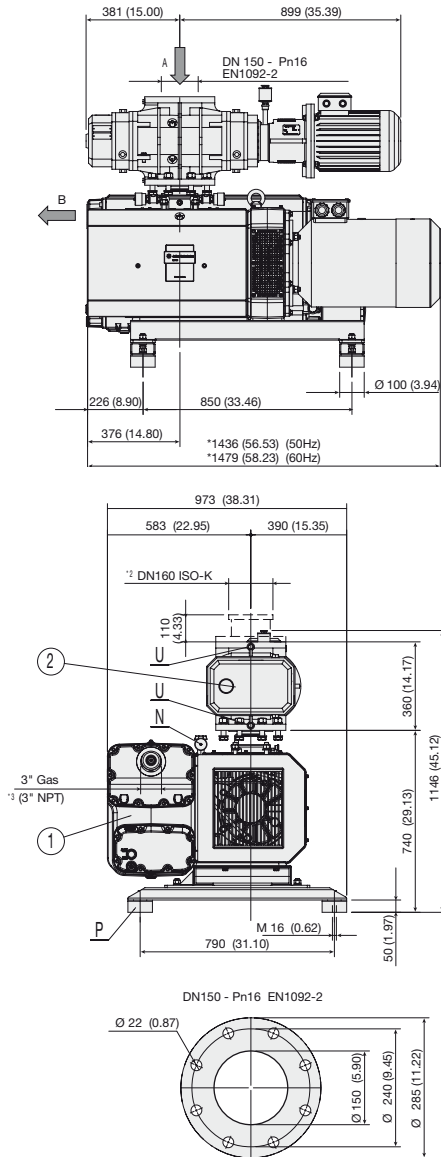

Dimensions: millimeters (inches)

RPS-1401 / MS-631 FL - Pumping Speed

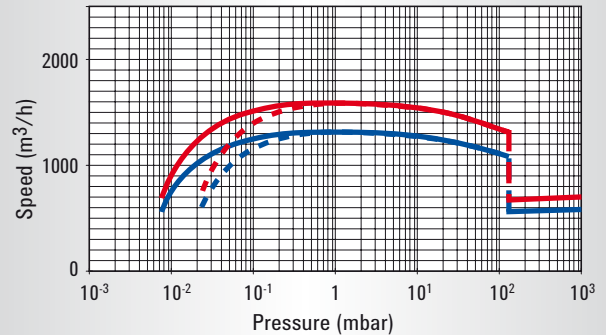

— 50 Hz w/o gasballast — 60 Hz w/o gasballast
 - - 50 Hz with gasballast - - 60 Hz with gasballast

High Capacity
MS-RPS Pumps

Technical Specifications

Nominal speed*	1430 m ³ /h (at 50 Hz) 1720 m ³ /h (at 60 Hz)
Ultimate partial pressure (with gas ballast valve closed)* (absolute)	≤ 0.007 mbar (≤ 0.005 Torr)
Ultimate total pressure (with gas ballast valve open)* (absolute)	≤ 0.02 mbar (≤ 0.015 Torr)
Start up pressure RP1401 (absolute)	≤ 130 mbar (≤ 97 Torr)
Fitted motor power** (MS + RP)	15 + 5.5 (400 V) kW at 50 Hz 18.5 + 5.5 (460 V) kW at 50 Hz
Noise pressure level***	75 dB(A) at 50 Hz 76.5 dB(A) at 60 Hz
Oil capacity (MS + RP) nominal	22 + 1.5 l
Weight	
with 3 ph 50 Hz motor	868 (1911.94) kg (lb)
with 3 ph 60 Hz motor	937 (2063.92) kg (lb)

* According to PNEURO standard 6602

** Valid for temperatures up to 40 °C and altitudes lower than 1000 m

*** According to UNI EN ISO 2151 standard

Ordering Information

For Roots pumps Part Numbers please see page 23 to 25

PUMP MODELS

► RPS-2001 / MS-631 FL System

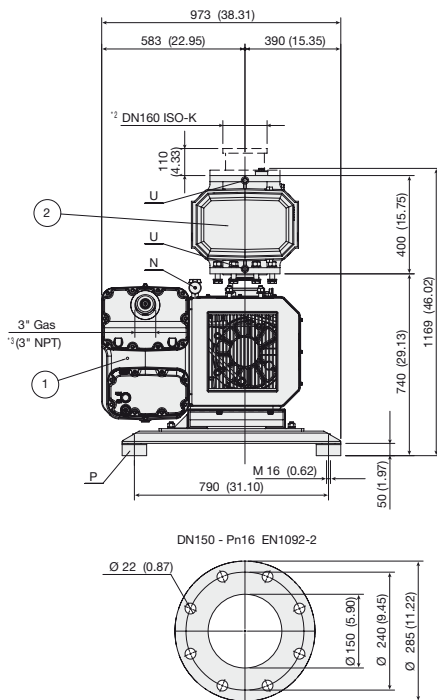
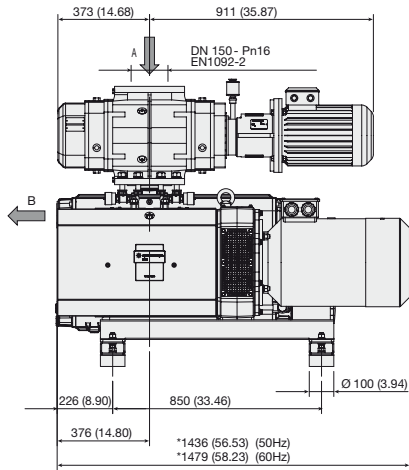

Dimensions: millimeters (inches)

RPS-2001 / MS-631 FL - Pumping Speed

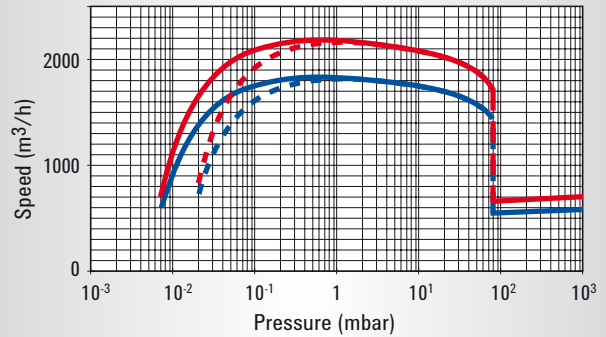

— 50 Hz w/o gasballast — 60 Hz w/o gasballast
 - - - 50 Hz with gasballast - - - 60 Hz with gasballast

Technical Specifications

Nominal speed*	2045 m ³ /h (at 50 Hz) 2444 m ³ /h (at 60 Hz)
Ultimate total pressure (with gas ballast valve closed)* (absolute)	≤ 7 x 10 ⁻³ mbar (≤ 7 x 10 ⁻¹ Pascal)
Ultimate total pressure (with gas ballast valve open)* (absolute)	≤ 2 x 10 ⁻² mbar (≤ 2 Pascal)
Start up pressure RP2001 (absolute)	≤ 80 mbar (≤ 60 Torr)
Fitted motor power** (MS + RP)	15 + 7.5 (400 V) kW at 50 Hz 18.5 + 7.5 (460 V) kW at 50 Hz
Noise pressure level***	77 dB(A) at 50 Hz 78 dB(A) at 60 Hz
Oil capacity (MS + RP) nominal	22 + 2.5 l
Weight	
with 3 ph 50 Hz motor	920 (2026.48) kg (lb)
with 3 ph 60 Hz motor	986 (2171.85) kg (lb)

* According to PNEURO standard 6602

** Valid for temperatures up to 40 °C and altitudes lower than 1000 m

*** According to UNI EN ISO 2151 standard

Ordering Information

For Roots pumps Part Numbers please see page 23 to 25

HIGH CAPACITY MS-RPS SERIES

RPS-3001 / MS-631 FL System

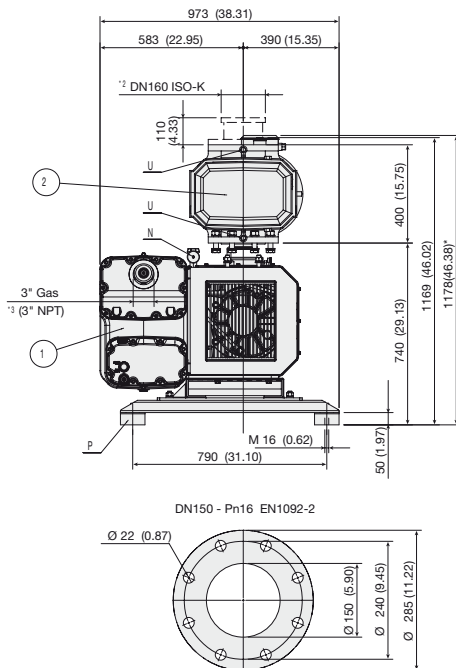
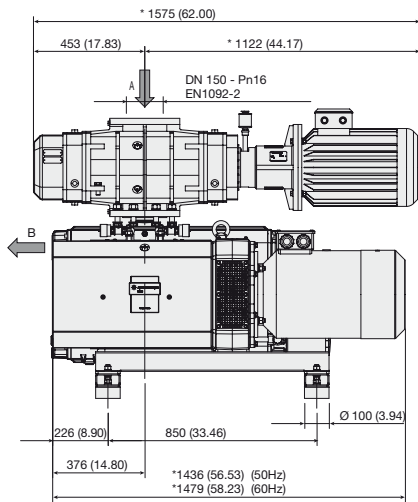

Dimensions: millimeters (inches)

RPS-3001 / MS-631 FL - Pumping Speed

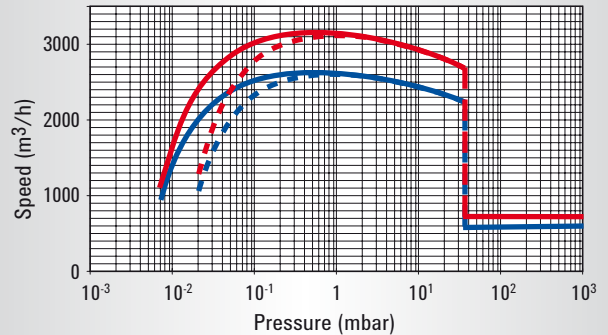

— 50 Hz w/o gasballast — 60 Hz w/o gasballast
 - - - 50 Hz with gasballast - - - 60 Hz with gasballast

Technical Specifications

Nominal speed*	2890 m ³ /h (at 50 Hz) 3465 m ³ /h (at 60 Hz)
Ultimate total pressure (with gas ballast valve closed)* (absolute)	≤ 7 x 10 ⁻³ mbar (≤ 7 x 10 ⁻¹ Pascal)
Ultimate total pressure (with gas ballast valve open)* (absolute)	≤ 2 x 10 ⁻² mbar (≤ 2 Pascal)
Start up pressure RP3001 (absolute)	< 36 mbar (< 27 Torr)
Fitted motor power** (MS + RP)	15 + 11 (400 V) kW at 50 Hz 18.5 + 11 (460 V) kW at 50 Hz
Noise pressure level***	77.5 dB(A) at 50 Hz 78.5 dB(A) at 60 Hz
Oil capacity (MS + RP) nominal	22 + 2.5 l
Weight	
with 3 ph 50 Hz motor	1052 (2317.23) kg (lb)
with 3 ph 60 Hz motor	1140 (2511.07) kg (lb)

* According to PNEURO standard 6602

** Valid for temperatures up to 40 °C and altitudes lower than 1000 m

*** According to UNI EN ISO 2151 standard

Ordering Information

For Roots pumps Part Numbers please see page 23 to 25

RPS PUMPING SYSTEMS MODELS

▶ Agilent RPS-Series Roots Pumping Systems

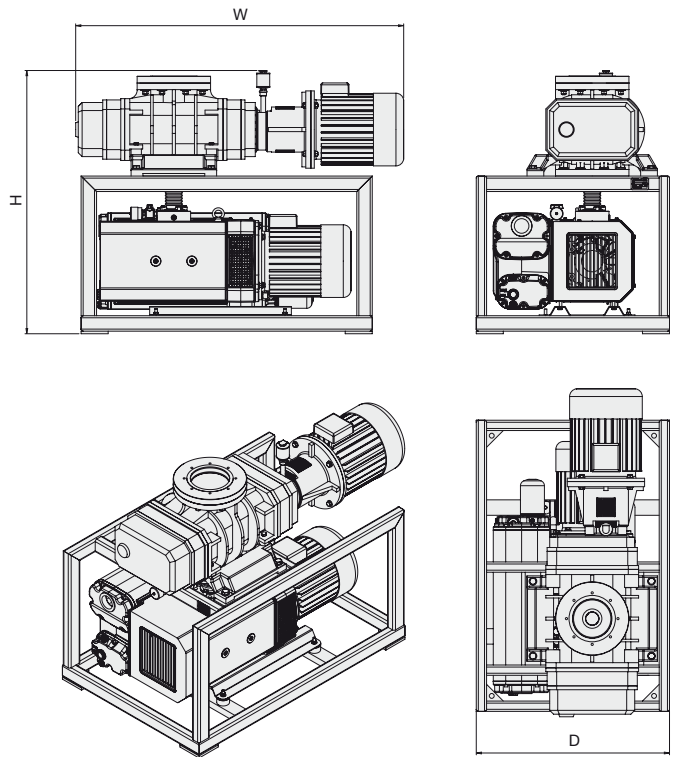

Roots Pumping Systems (RPS) consist of one MS Rotary Vane Pump and one RP Roots Pump, assembled on a dedicated frame, and connected in series with a flexible hose. This assembly is shipped with the pumps mounted on the frame and leak checked. Both pumps are equipped with motor.

Photo and Outline Drawing: RPS-1401/301

▶ Agilent RP-Series Roots Pumps

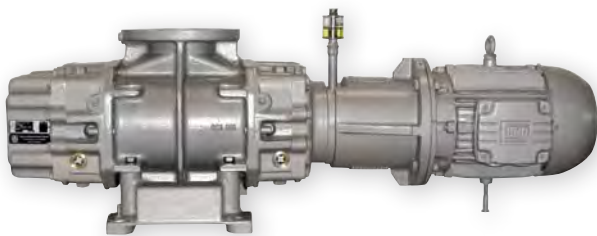

State-of-the-art, high performance Agilent Roots Pumps are ideal for use in demanding industrial applications:

- Highest compression ratio
- Agilent Roots Pumps can withstand high mechanical loads reducing pumpdown cycles
- Lowest base pressure: 5×10^{-3} mbar (4×10^{-3} Torr)

HIGH CAPACITY MS-RPS SERIES

High Capacity MS-RPS Pumps

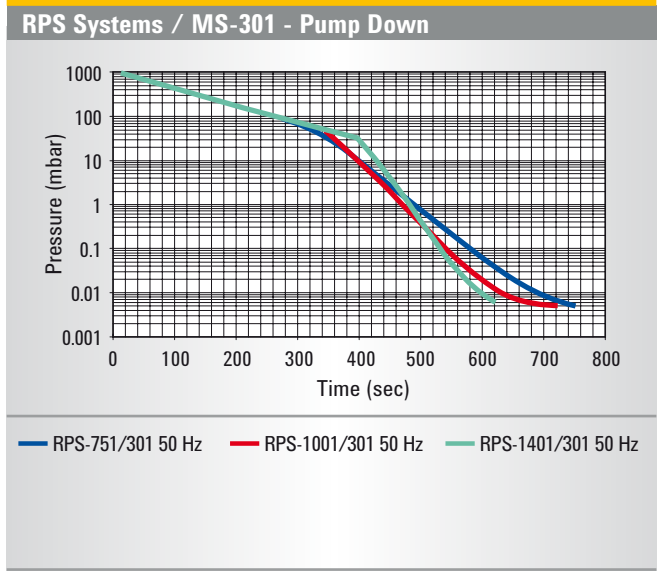
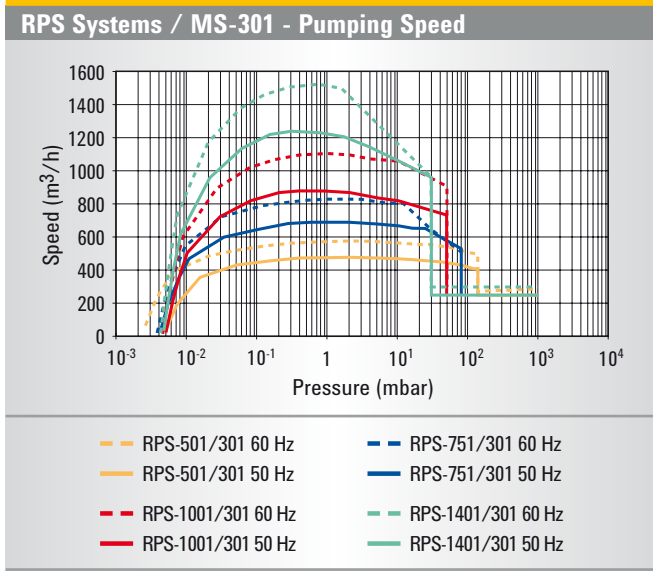

Technical Specifications

		RPS-501/301	RPS-751/301
Nominal pumping speed	60 Hz	600 m ³ /h (350 cfm)	900 m ³ /h (530 cfm)
	50 Hz	500 m ³ /h (300 cfm)	750 m ³ /h (440 cfm)
Ultimate total pressure (gas ballast closed)		≤ 7 × 10 ⁻³ mbar (≤ 5 × 10 ⁻³ Torr)	≤ 5 × 10 ⁻³ mbar (≤ 4 × 10 ⁻³ Torr)
Roots pump start up pressure		≤ 200 mbar (≤ 152 Torr)	≤ 80 mbar (≤ 60 Torr)
Power	60 Hz	2.6 + 7.5 kW (3.5 + 10.0 HP)	3.6 + 7.5 kW (4.8 + 10.0 HP)
	50 Hz	2.2 + 5.5 kW (2.9 + 7.3 HP)	3.0 + 5.5 kW (4.0 + 7.3 HP)
Power supply voltage		Δ230/Y400 V at 50 Hz Δ460 V at 60 Hz YY230/Y460 V at 60 Hz Δ220/Y380 V at 60 Hz	Δ230/Y400 V at 50 Hz Δ460 V at 60 Hz YY230/Y460 V at 60 Hz Δ220/Y380 V at 60 Hz
Noise level*		74 / 76 dB(A)	74 / 76 dB(A)
Oil charge		1.1 + 7.0 liter (1.16 + 7.4 qt)	1.5 + 7.0 liter (1.6 + 7.4 qt)
Working ambient temperature range		+12 +40 °C (+54 +105 F)	+12 +40 °C (+54 +105 F)
Storage temperature		-15 +50 °C (+5 +122 F)	-20 +70 °C (-4 +158 F)
Dimensions D x W x H		750 x 1048 x 1086 / 750 x 1088 x 1086 mm (29.5 x 41.3 x 42.8 / 29.5 x 42.8 x 42.8 in.)	750 x 1130 x 1175 mm (29.5 x 44.5 x 46.3 in.)
Total weight	60 Hz	445 kg (981 lbs)	470 kg (1040 lbs)
	50 Hz	430 kg (948 lbs)	450 kg (1000 lbs)
		RPS-1001/301	RPS-1401/301
Nominal pumping speed	60 Hz	1200 m ³ /h (710 cfm)	1700 m ³ /h (1000 cfm)
	50 Hz	1000 m ³ /h (590 cfm)	1430 m ³ /h (840 cfm)
Ultimate total pressure (gas ballast closed)		≤ 5 × 10 ⁻³ mbar (≤ 4 × 10 ⁻³ Torr)	≤ 5 × 10 ⁻³ mbar (≤ 4 × 10 ⁻³ Torr)
Roots pump start up pressure		≤ 50 mbar (≤ 38 Torr)	≤ 30 mbar (≤ 23 Torr)
Power	60 Hz	4.8 + 7.5 kW (6.4 + 10.0 HP)	6.3 + 7.5 kW (8.4 + 10.0 HP)
	50 Hz	4.0 + 5.5 kW (5.3 + 7.3 HP)	5.5 + 5.5 kW (7.3 + 7.3 HP)
Power supply voltage		Δ230/Y400 V at 50 Hz Δ400/Y690 V at 50 Hz Δ460 V at 60 Hz YY230/Y460 V at 60 Hz Δ220/Y380 V at 60 Hz	Δ230/Y400 V at 50 Hz Δ400/Y690 V at 50 Hz Δ460 V at 60 Hz YY230/Y460 V at 60 Hz Δ220/Y380 V at 60 Hz
Noise level*		74 / 76 dB(A)	74 / 76 dB(A)
Oil charge		1.5 + 7.0 liter (1.6 + 7.4 qt)	1.5 + 7.0 liter (1.6 + 7.4 qt)
Working ambient temperature range		+12 +40 °C (+54 +105 F)	+12 +40 °C (+54 +105 F)
Storage temperature		-20 +70 °C (-4 +158 F)	-20 +70 °C (-4 +158 F)
Dimensions D x W x H		750 x 1153 x 1195 mm (29.5 x 45.4 x 47 in.)	750 x 1289 x 1195 mm (29.5 x 50.7 x 47 in.)
Total weight	60 Hz	530 kg (1170 lbs)	590 kg (1300 lbs)
	50 Hz	510 kg (1130 lbs)	570 kg (1260 lbs)

* Measured according to EN ISO 2151 (50/60 Hz)

RPS PUMPING SYSTEMS MODELS

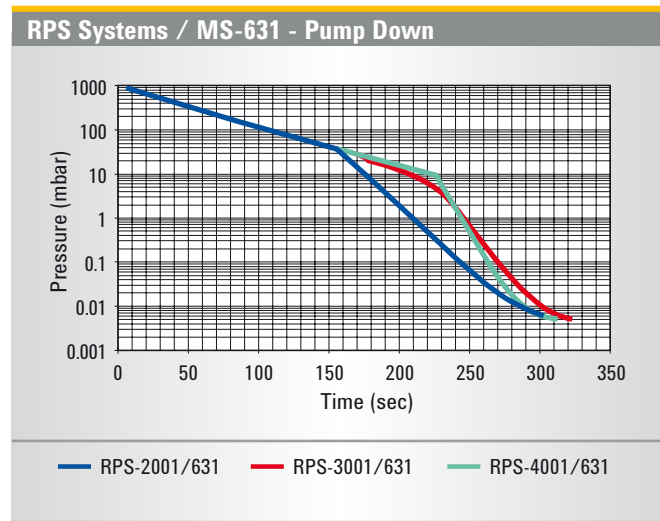
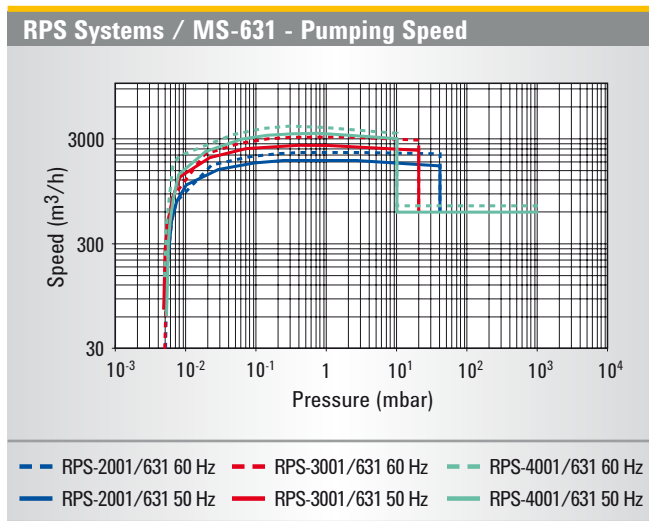

Technical Specifications

		RPS-2001/631		RPS-3001/631	
Nominal pumping speed	60 Hz	2400 m ³ /h (1415 cfm)		3450 m ³ /h (2030 cfm)	
	50 Hz	2000 m ³ /h (1180 cfm)		2900 m ³ /h (1710 cfm)	
Ultimate total pressure (gas ballast closed)		≤ 5 x 10 ⁻³ mbar (≤ 4 x 10 ⁻³ Torr)		≤ 5 x 10 ⁻³ mbar (≤ 4 x 10 ⁻³ Torr)	
Roots pump start up pressure		≤ 55 mbar (≤ 42 Torr)		≤ 30 mbar (≤ 23 Torr)	
Power	60 Hz	8.8 + 18.5 kW (11.8 + 24.8 HP)		12.5 + 18.5 kW (16.7 + 24.8 HP)	
	50 Hz	7.5 + 15.0 kW (10.0 + 20.1 HP)		11.0 + 15.0 kW (14.7 + 20.1 HP)	
Power supply voltage		Δ400/Y690 V at 50 Hz Δ460 V at 60 Hz YY230/Y460 V at 60 Hz Δ220/Y380 V at 60 Hz		Δ400/Y690 V at 50 Hz Δ460 V at 60 Hz YY230/Y460 V at 60 Hz Δ220/Y380 V at 60 Hz	
Noise level*		78 / 80 dB(A)		78 / 80 dB(A)	
Oil charge		2.5 + 22.0 liter (2.6 + 23.2 qt)		2.5 + 22.0 liter (2.6 + 23.2 qt)	
Working ambient temperature range		+12 +40 °C (+54 +105 F)		+12 +40 °C (+54 +105 F)	
Storage temperature		-20 +70 °C (-4 +158 F)		-20 +70 °C (-4 +158 F)	
Dimensions D x W x H		1050 x 1575 [1605 version 60 Hz] x 1516 mm (41.3 x 62 [63.2 version 60 Hz] x 59.7 in.)		1050 x 1615 x 1516 mm (41.3 x 63.6 x 59.7 in.)	
Total weight	60 Hz	1115 kg (2460 lbs)		1255 kg (2770 lbs)	
	50 Hz	1085 kg (2400 lbs)		1225 kg (2700 lbs)	
		RPS-4001/631			
Nominal pumping speed	60 Hz	4700 m ³ /h (2770 cfm)			
	50 Hz	3900 m ³ /h (2300 cfm)			
Ultimate total pressure (gas ballast closed)		≤ 5 x 10 ⁻³ mbar (≤ 4 x 10 ⁻³ Torr)			
Roots pump start up pressure		≤ 16 mbar (≤ 12 Torr)			
Power	60 Hz	12.5 + 18.5 kW (16.7 + 24.8 HP)			
	50 Hz	11.0 + 15.0 kW (14.7 + 20.1 HP)			
Power supply voltage		Δ400/Y690 V at 50 Hz Δ460 V at 60 Hz YY230/Y460 V at 60 Hz Δ220/Y380 V at 60 Hz			
Noise level*		79 / 81 dB(A)			
Oil charge		7.0 + 22.0 liter (7.4 + 23.2 qt)			
Working ambient temperature range		+12 +40 °C (+54 +105 F)			
Storage temperature		-20 +70 °C (-4 +158 F)			
Dimensions D x W x H		1050 x 1636 x 1576 mm (41.3 x 64.4 x 62 in.)			
Total weight	60 Hz	1380 kg (3050 lbs)			
	50 Hz	1340 kg (2960 lbs)			

* measured according to EN ISO 2151 (50/60 Hz)

HIGH CAPACITY MS-RPS SERIES

Ordering Information

Roots Pumping Systems including: Roots Pump, RV Pump, Frame, Flexible Hose, Roots Pump Oil, Assembly, Testing and Packaging. MS PUMP OIL CHARGE NOT INCLUDED.	Part Number
RPS-501/301, 230/400V, 50Hz	X3755-64000
RPS-501/301, 230/460V, 60Hz (US version)	X3755-64008
RPS-501/301, 220/380V, 60Hz	X3755-64012
RPS-751/301, 230/400V, 50Hz	X3755-64001
RPS-751/301, 230/460V, 60Hz (US version)	X3755-64009
RPS-751/301, 220/380V, 60Hz	X3755-64013
RPS-1001/301, 230/400V, 50Hz	X3755-64002
RPS-1001/301, 400/690V, 50Hz	X3755-64004
RPS-1001/301, 400/690V, 50Hz - 460V,60Hz	X3755-64006
RPS-1001/301, 230/460V, 60Hz (US version)	X3755-64010
RPS-1001/301, 220/380V, 60Hz	X3755-64014
RPS-1401/301, 230/400V, 50Hz	X3755-64003
RPS-1401/301, 400/690V, 50Hz	X3755-64005
RPS-1401/301, 400/690V, 50Hz - 460V,60Hz	X3755-64007
RPS-1401/301, 230/460V, 60Hz (US version)	X3755-64011
RPS-1401/301, 220/380V, 60Hz	X3755-64015
RPS-2001/631, 400/690V, 50Hz	X3756-64002
RPS-2001/631, 400/690V, 50Hz - 460V,60Hz	X3756-64007
RPS-2001/631, 230/460V, 60Hz (US version)	X3756-64012
RPS-2001/631, 220/380V, 60Hz	X3756-64017
RPS-3001/631, 400/690V, 50Hz	X3756-64003
RPS-3001/631, 400/690V, 50Hz - 460V,60Hz	X3756-64008
RPS-3001/631, 230/460V, 60Hz (US version)	X3756-64013
RPS-3001/631, 220/380V, 60Hz	X3756-64018
RPS-4001/631, 400/690V, 50Hz	X3756-64004
RPS-4001/631, 400/690V, 50Hz - 460V,60Hz	X3756-64009
RPS-4001/631, 230/460V, 60Hz (US version)	X3756-64014
RPS-4001/631, 220/380V, 60Hz	X3756-64019

* Other combinations available on request. Please contact Agilent for details

RPS PUMPING SYSTEMS MODELS

Ordering Information

Roots Pumps / MS PUMP OIL CHARGE NOT INCLUDED	Part Number
RP-251, 1.1kW, 230/400V, 50Hz-460V, 60Hz	X3757-64251
RP-251, 1.1kW, 230/460V, 60Hz	X3757-64252
RP-251, 1.1kW, 220/380V, 60Hz	X3757-64253
RP-501, 2.2kW 230/400V, 50Hz - 460V, 60Hz	X3757-64501
RP-501, 2.2kW, 230/460V, 60Hz	X3757-64502
RP-501, 2.2kW, 220/380V, 60Hz	X3757-64503
RP-751, 3kW, 230/400V, 50Hz - 460V, 60Hz	X3758-64751
RP-751, 3kW, 230/460V, 60Hz	X3758-64752
RP-751, 3kW, 220/380V, 60Hz	X3758-64753
RP-1001, 4kW, 230/400V, 50Hz - 460V, 60Hz	X3758-64001
RP-1001, 4kW, 400/690V, 50Hz - 460V, 60Hz	X3758-64002
RP-1001, 4kW, 230/460V, 60Hz	X3758-64003
RP-1001, 4kW, 230/380V, 60Hz	X3758-64004
RP-1401, 4kW, 220/380V, 60Hz - To be used with VFD	X3758-64007
RP-1401, 4kW, 230/400V, 50Hz - 460V, 60Hz - To be used with VFD	X3758-64009
RP-1401, 4kW, 400/690V, 50Hz - 460V, 60Hz - To be used with VFD	X3758-64010
RP-1401, 5.5kW 230/400V, 50Hz-460V, 60Hz	X3758-64401
RP-1401, 5.5kW 400/690V, 50Hz-460V, 60Hz	X3758-64402
RP-1401, 5.5kW, 230/460V, 60Hz	X3758-64403
RP-1401, 5.5kW, 230/380V, 60Hz	X3758-64404
RP-2001, 5.5kW, 220/380V, 60Hz - To be used with VFD	X3759-64001
RP-2001, 5.5kW, 230/460V, 60Hz - To be used with VFD	X3759-64002
RP-2001, 5.5kW, 400/690V, 50Hz-460V, 60Hz - To be used with VFD	X3759-64003
RP-2001, 7.5kW 400/690V, 50Hz-460V, 60Hz	X3759-64201
RP-2001, 7.5kW, 230/460V, 60Hz	X3759-64202
RP-2001, 7.5kW, 230/380V, 60Hz	X3759-64203
RP-3001, 11kW 400/690V, 50Hz-460V, 60Hz	X3759-64301
RP-3001, 11kW, 230/460V, 60Hz	X3759-64302
RP-3001, 11kW, 230/380V, 60Hz	X3759-64303
RP-4001, 11kW 400/690V, 50Hz-460V, 60Hz	X3759-64401
RP-4001, 11kW, 230/460V, 60Hz	X3759-64402
RP-4001, 11kW, 230/380V, 60Hz	X3759-64403
Inverter 4kW, three-phase, 380-480V, IP20, plus software suitable for RP-1401 paired with MS-631	X3761-64012
Inverter 4kW, three-phase, 380-480V, IP66, plus software suitable for RP-1401 paired with MS-631	X3761-64013
Inverter 5.5kW, three-phase, 380-480V, IP20, plus software suitable for RP-2001 paired with MS-631	X3761-64014
Inverter 5.5kW, three-phase, 380-480V, IP66, plus software suitable for RP-2001 paired with MS-631	X3761-64015
Support Mounting Kit, for 4kW inverter	X3761-64016
Support Mounting Kit, for 5.5kW inverter	X3761-64017

HIGH CAPACITY MS-RPS SERIES

Ordering Information

Spare Part Kits & Accessories	Part Number
RP-1001 Minor Spare Part Kit	9497020
RP-751 Minor Spare Part Kit	9497021
RP-1401 Minor Spare Part Kit	9497022
RP-2001 Minor Spare Part Kit	9497023
RP-3001 Minor Spare Part Kit	9497024
RP-4001 Minor Spare Part Kit	9497025
RP-1001 Major Spare Part Kit	9497026
RP-751 Major Spare Part Kit	9497027
RP-1401 Major Spare Part Kit	9497028
RP-2001 Major Spare Part Kit	9497029
RP-3001 Major Spare Part Kit	9497030
RP-4001 Major Spare Part Kit	9497031
DN80Pn16 to DN63ISO-K Adapter Flange Kit	X3761-64000
DN100Pn16 to DN63ISO-K Adapter Flange Kit	X3761-64001
DN100Pn16 to DN100ISO-K Adapter Flange Kit	X3761-64002
DN150Pn16 to DN100ISO-K Adapter Flange Kit	X3761-64003
DN150Pn16 to DN160ISO-K Adapter Flange Kit	X3761-64004
DN63 ISO-K Inlet Mesh Kit	X3761-64005
DN100 ISO-K Inlet Mesh Kit	X3761-64006
DN160 ISO-K Inlet Mesh Kit	X3761-64007



AGILENT DRY SCROLL PUMPS

- 2-3 Features and Benefits
- 4-5 Typical Applications
- 6-7 New IDP-15 Dry Scroll Pump
- 8-26 Pump Models
- 27-33 Scroll Accessories
- 34-35 Scroll Maintenance



Agilent Technologies

SCROLL PUMPS FEATURES AND BENEFITS

Agilent dry scroll pumps create vacuum using a dual scroll mechanism where one nested scroll orbits the other creating moving zones of captured gas.

Gas enters the scroll set at the perimeter and is displaced and compressed toward the center hub where it is exhausted. This design offers many benefits such as low noise and vibration, simple and infrequent maintenance, and elimination of catastrophic failure modes.



Gas enters scroll set



Gas is displaced and...



...compressed toward center hub



Gas exhausted at center hub

SH and IDP series of scroll pumps employ a single stage design that delivers dry vacuum in a small, economical, reliable package making these pumps ideally suited for many applications including Analytical Instruments and Research and Development. This simple design utilizes proven seal technology for longer demonstrated maintenance intervals.

Agilent TriScroll and TriScroll Inverter pumps are two-stage scroll pumps that achieve the lowest ultimate pressure of any dry pump technology on the market today.

NEW

IDP-15



SH-110

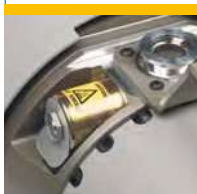

Built-In Vacuum Pump Isolation Valve

SH Series standard, IDP and TriScroll optional

Isolates the pump during vacuum system fault conditions and power loss; prevents contamination of the vacuum system.

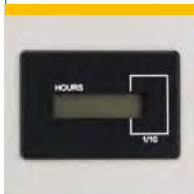

Hour Meter

SH and IDP Series standard
Gives an accurate measurement of total run time which facilitates maintenance planning.

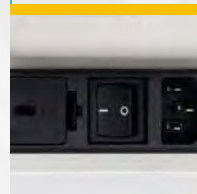

Fuse Holder and Voltage Changeover Tab

SH-110, SH-112 and IDP-15 only
Easy and quick voltage selection.

On/Off Switch

Easily accessible.

IEC 320 Power Connection

Flexible electrical connections for easy installation worldwide.

DRY SCROLL PUMPS



Single-sided Scroll
SH and IDP series
Enables quick and easy tip seal change.



Proven Reliability
With over 25,000 Agilent manufactured scroll pumps operating worldwide, the Agilent scroll technology has demonstrated exceptional reliability.



Unique TriScroll Design
Delivers high pumping speed and achieves low ultimate pressure, within a compact design.



IDP-3

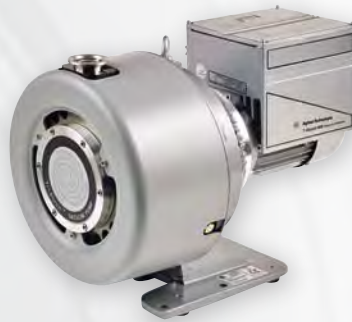

TriScroll 600
Inverter



TriScroll 300



**Inverter-driven
Scroll
Pumps**

deliver constant pumping speed worldwide regardless of line frequency. Inverters allow selection of the optimal pumping speed for any application by adjusting the rotational speed of the pump.

A 9 pin D-shell connector allows remote start and stop with a contact closure, and the serial interface enables monitoring of the pump parameters and remote start capability.

For more information, see page 26.

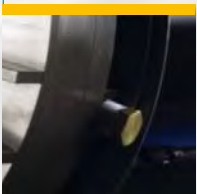

Bearing Purge Port
TriScrolls only
Improved tolerance for condensable gases by purging the shaft bearings with dry gas.

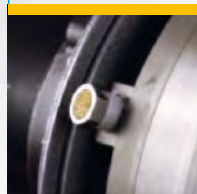

Gas Ballast Port
All scrolls
Improves tolerance for water vapor and handling of condensable gases for consistent performance.

TYPICAL APPLICATIONS

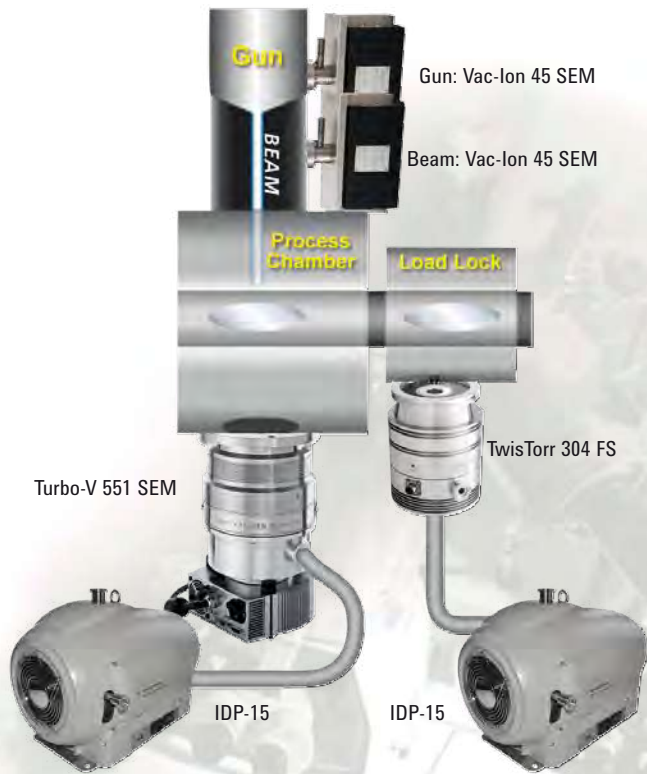

Load Locks and Transfer Chambers

Scroll pumps are proven as a highly reliable and low maintenance choice for clean dry pumping in production equipment on load locks and transfer chambers.

Beam Lines

Fast and oil-free pump down in combination with turbomolecular pumps and ion pumps. Scroll pumps are part of a total Agilent Technologies dry product offering, including turbo pumps and ion pumps.

Mass Spec Instruments

The quiet, clean, low-vibration IDP-15 Scroll pump provides dry primary vacuum with simple, infrequent tip seal change.

Scanning Electron Microscopes

Agilent scroll pumps provide clean and reliable dry vacuum, ideal for maintaining the critical condition of instrument columns.

General Purpose Laboratory Applications

Proven scroll technology provides predictable dry vacuum at low base pressure for long periods of time. Scroll design eliminates all possibility of sudden and catastrophic failure associated with technologies such as diaphragm pumps. The IDP-3 and the SH-110 are light in weight – the IDP-3 weighs in at 21 pounds – and are equipped with handles for easy mobility around the lab.

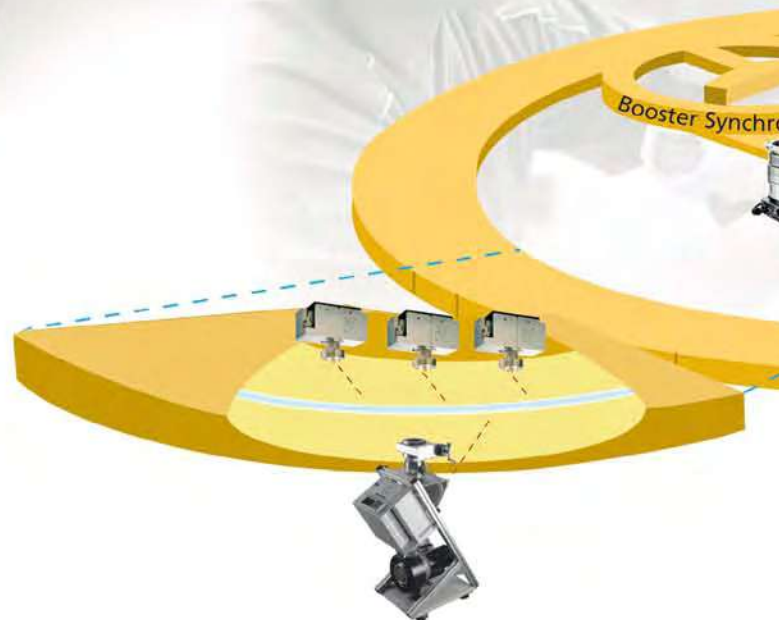

DRY SCROLL PUMPS

Drying Ovens

Scroll pumps eliminate the risk of backstreaming rotary vane pump oil vapors into the oven system. The gas ballast feature guarantees reliable operation where water vapor is to be pumped.

Cryogenics/Helium Recirculation

Scroll pumps are commonly used for regeneration of cryogenic pumps. Use of the inert gas purge kit accessory is recommended for this application to enhance pumping of condensable vapor.

Manufacturing/Glove Box Enclosures

Scroll pumps are an economical choice for critical manufacturing, eliminating the risk of oil contamination, and costly waste disposal. Agilent scroll pumps keep the manufacturing environment hydrocarbon free.



Dry Scroll Pumps

Primary Backing Pump for Turbo Systems

The scroll pump is the ideal selection for backing high vacuum turbo pumps, such as in the mass spectrometer shown above, eliminating the risk of system contamination.

Leak Detection

The TriScroll modules used in Helium Mass Spectrometer Leak Detection have been specifically optimized for this application, improving the compression ratio for Helium.

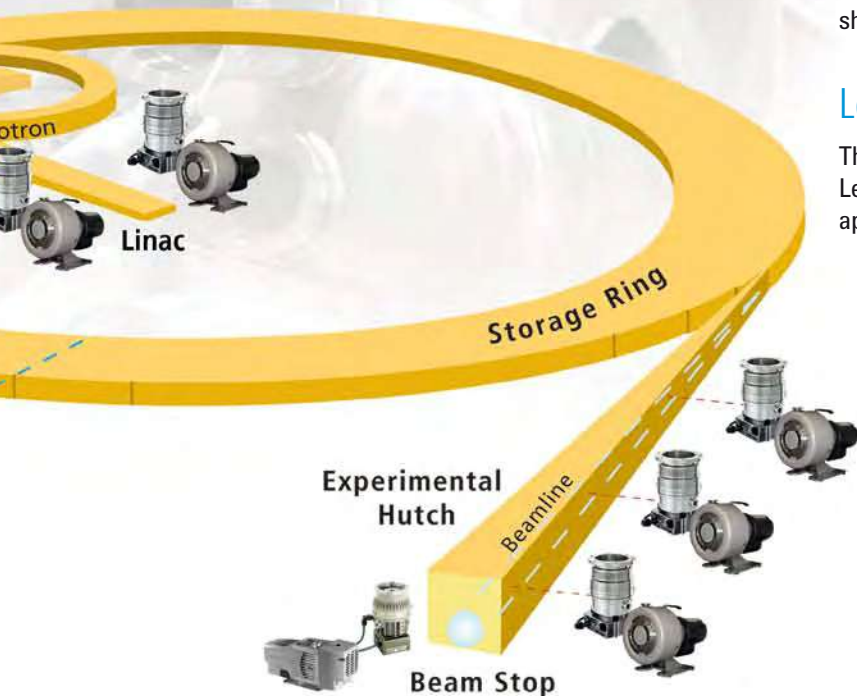

NEW IDP-15 DRY SCROLL PUMP

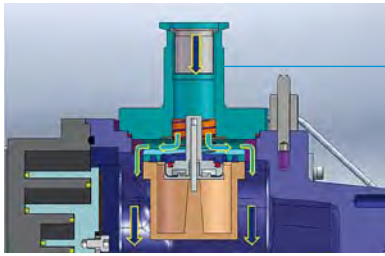

Vacuum in pump, inlet valve opens

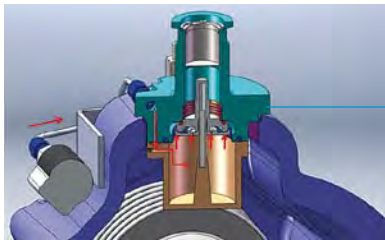

Pump vents, inlet valve closes

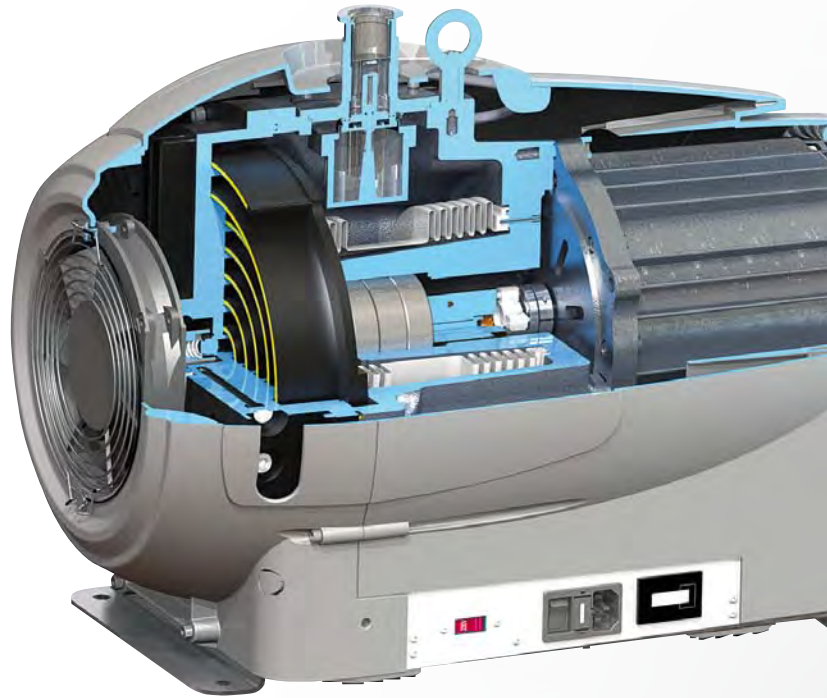

Optional Integral Isolation Valve

- The Integral Inlet Isolation Valve is installed inside the module; it adds no height to the pump inlet
- Valve protects against backward migration through the inlet, and sudden venting of customer chamber/instrument
- Spring holds inlet valve normally closed
- Lower pressure in pump causes spring to open
- On power loss, solenoid valve vents pump causing inlet valve to close (20 ms)
- Power is restored, solenoid closes, inside of pump begins evacuating, inlet valve opens (about 10 sec)

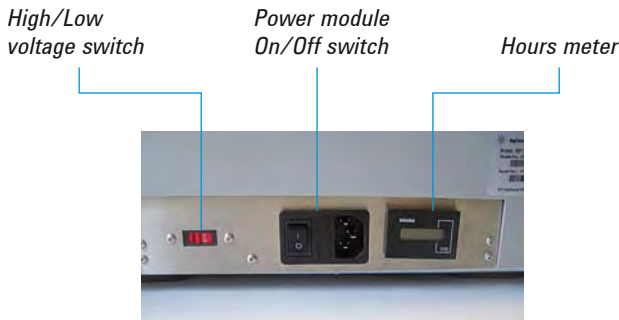

Fixed Speed Motor Supports Global Input Voltages

- Supports single phase operating voltages:
 - 100 V, 50/60 Hz
 - 115 V, 60 Hz
 - 220-230 V, 50/60 Hz
- Simple switch to change between high and low voltage use



Outer cowling acts as noise enclosure

Designed for Quiet Operation Low Noise

- Agilent consulted with noise experts to aid in designing Pump Module to minimize noise
- Three piece outer cowling acts as a built-in noise enclosure
- IDP-15 is specified at 50 dBA \pm 2 dBA, much lower than other scroll pumps available

DRY SCROLL PUMPS

Isolated and Hermetic Design

Motor and bearings completely isolated from the vacuum path

- Motor and bearings are not exposed to any process gases or water vapor from the application
- Bearings run at atmospheric pressure

Hermetic design

- Appropriate for Rare Gas and Helium recirculation applications
- Gas ballast normally closed
- Closed system from inlet to exhaust
- Each pump is leak checked



Single Sided Scroll Design

- Only Fixed Scroll needs to be removed to change tip seals
- Very easy basic service, 15 minutes using two tools
- Simple design still achieves a low ultimate pressure of 10 mTorr

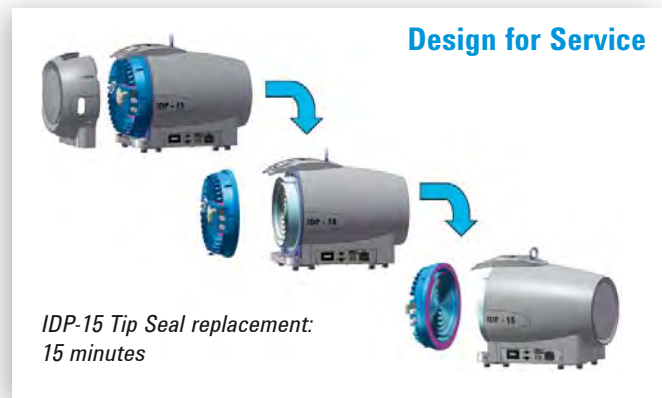

Dry Scroll Pumps

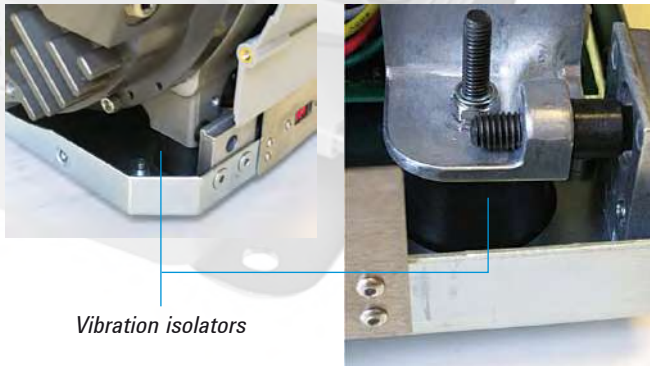

Vibration isolators

Low Vibration

The IDP-15 is equipped with integral Vibration Isolation feet, which:

- Decouple vibration from motor and scrolls from the mounting brackets
- Dampen vibration of the pump module

How Quiet is the IDP-15?

Noise	dBA
Chainsaw; thunder clap	120
Car horn (1 m); live rock music	110
Lawn mower; airplane take off (1km)	100
Motorcycle (8 m away)	90
Freight train (25 m); food blender	80
Cars on freeway; vacuum cleaner	70
Air conditioner (30 m); office noise	60
Best competing scroll pump	52
Conversation at home; IDP-15	50
Library	40

Every additional 10 dBA is a doubling of noise

PUMP SPECIFICATIONS

		IDP-3	SH-110/SH-112	IDP-15
Pumping speed	60 Hz l/min, m ³ /h, cfm	60, 3.6, 2.1	110, 6.6, 4.0	256, 15.4, 9.1
	50 Hz l/min, m ³ /h, cfm	50, 3.0, 1.8	90, 5.4, 3.3	214, 12.8, 7.5
Ultimate pressure, mbar (Torr)		3.3×10^{-1} (2.5×10^{-1})	SH-110: 6.6×10^{-2} (5×10^{-2}) SH-112: 2.6×10^{-1} (2×10^{-1})	1.3×10^{-2} (1×10^{-2})
Maximum inlet pressure, atm (psig)		1.0 (0)	1.0 (0)	1.0 (0)
Maximum outlet pressure, atm (psig)		1.4 (6.5)	1.5 (7.5)	1.4 (6.5)
Inlet connection		NW16	NW25	NW25
Exhaust connection		¼ " Female NPT (10 mm hose barb provided)	¼ " Female NPT (NW16 adapter provided)	¼ " Female NPT (NW16)
Gas ballast		⅛ " Female NPT (20 micron sintered plug provided)	⅛ " Female NPT (20 micron sintered plug provided)	¼ " Female NPT (two positions)
Motor rating (1 phase), HP (kW)		0.16 (0.12)	0.25 (0.19)	0.75 (0.56)
Operating voltages (610%)	1Ø 60 Hz	100, 115, 220-230 V	100-115, 200-230 V	100-115, 220-230 V
	3Ø 60 Hz	100, 220-230 V	100-115, 200-230 V	100, 200-230 V
	50 Hz	—	—	—
	50 Hz	—	—	—
		24 VDC		
Motor thermal protection		Type U automatic	Type U automatic	Type U automatic
Operating speed	60 Hz (rpm)	3200	1725	1725
	50 Hz (rpm)	2600	1425	1450
Cooling system		Air-cooled	Air-cooled	Air-cooled
Ambient operating temperature, °C (°F)		5 to 40 (41 to 108)	5 to 40 (41 to 104)	5 to 45 (41 to 113)
Storage temperature, °C (°F)		-20 to 60 (-4 to 140)	-20 to 60 (-4 to 140)	-20 to 60 (-4 to 140)
Weight pump only, kg (lbs)		9.5 (21)	19 (43)	34 (75)
Shipping weight, kg (lbs)		10.5 (23)	20 (44)	45 (100)
Noise level (per ISO 11201), dB(A)		55	56	50 ±2
Vibration level (per ISO 10816-1) mm/sec		1.5	1.5	< 0.9



DRY SCROLL PUMPS

TriScroll 300	TriScroll 600	TriScroll 300 Inverter	TriScroll 600 Inverter
250, 15, 8.8 210, 12.6, 7.4	500, 30, 17.7 420, 25.2, 14.8	250, 15, 8.8	500, 30, 17.7
1.3×10^{-2} (1×10^{-2})	9.3×10^{-3} (7×10^{-3})	1.3×10^{-2} (1×10^{-2})	9.3×10^{-3} (7×10^{-3})
1.0 (0)	1.0 (0)	1.0 (0)	1.0 (0)
1.1 (1.5)	1.1 (1.5)	1.1 (1.5)	1.1 (1.5)
NW25	NW40	NW25	NW40
¼ " Female NPT with swivel (NW16 adapter provided)	¾ " Female NPT with swivel (NW25 adapter provided)	¼ " Female NPT with swivel (NW16 adapter provided)	¾ " Female NPT with swivel (NW25 adapter provided)
¼ " Female NPT (40 micron sintered filter provided)	¼ " Female NPT (40 micron sintered filter provided)	¼ " Female NPT (40 micron sintered filter provided)	¼ " Female NPT (40 micron sintered filter provided)
0.75 (0.56)	1.0 (0.76)	0.67 (0.5)	0.67 (0.5)
100-115, 200-230 V 100-115, 200-230 V 200-230, 460 V 200-230, 380-415 V	100-115, 200-230 V 100-115, 200-230 V 200-230, 460 V 200-230, 380-415 V	100-115, 200-240 V 100-115, 200-240 V – –	200-240 V 200-240 V – –
Type U automatic	Type U automatic	Automatic	Automatic
1725 1425	1725 1425	1800 @ 62 Hz	1800 @ 62 Hz
Air-cooled	Air-cooled	Air-cooled	Air-cooled
5 to 40 (41 to 104)	5 to 40 (41 to 104)	5 to 40 (41 to 104)	5 to 40 (41 to 104)
-20 to 60 (-4 to 140)	-20 to 60 (-4 to 140)	-20 to 60 (-4 to 140)	-20 to 60 (-4 to 140)
26.4 (57)	32 (70)	26 (57)	31 (68)
34.2 (75)	40 (87)	34 (74)	39 (85)
68	68	Variable with frequency 55 - 68	Variable with frequency 55 - 68
6.3	6.3	Variable with frequency	Variable with frequency



PUMP MODELS

▶ Agilent IDP-3

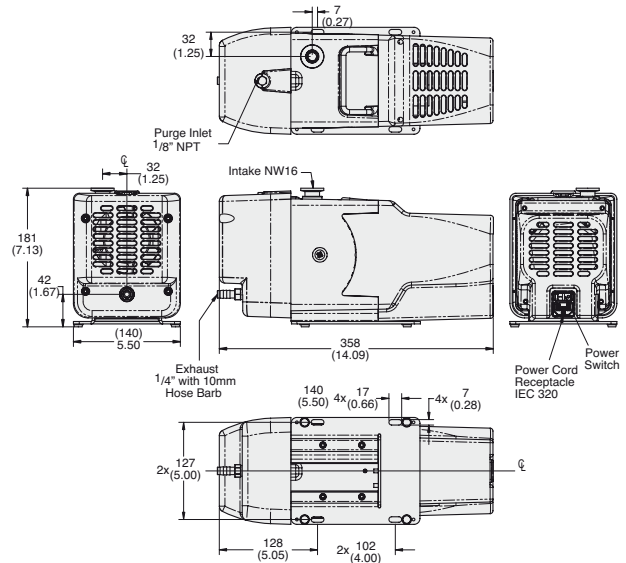

Dimensions: millimeters (inches)

The Agilent IDP-3 Dry Scroll Pump is an innovative, compact, high-performance, oil-free vacuum pump that is suitable for a wide variety of applications. It is the smallest scroll pump made for general vacuum applications, which makes it easy to integrate into OEM systems, and it weighs only 21 pounds (9.5 kg). Yet with a pumping speed of 60 l/m and a very low base pressure of 250 milliTorr, it is the highest-performing dry pump in its class.

- Oil-free - no contamination of the vacuum system
- Hermetic design with fully isolated motor and bearings
- Low noise and vibration
- No mechanisms subject to catastrophic failure
- Lower base pressure than diaphragm pumps
- Speed control on 24 VDC motor with 0-10V control signal
- Hour meter is standard on all IDP-3 units

Technical Specifications

Pumping speed	60 Hz: 60 l/m, 3.6 m ³ /hr, 2.1 cfm 50 Hz: 50 l/m, 3.0 m ³ /hr, 1.8 cfm
Ultimate pressure	2.5 x 10 ⁻¹ Torr (3.3 x 10 ⁻¹ mbar)
Maximum inlet pressure	1 atmosphere (0 psig)
Maximum outlet pressure	1.4 atmosphere (6.5 psig)
Inlet connection	NW16 flange
Exhaust connection	1/4" Female NPT (10 mm hose barb provided)
Gas ballast	1/8" Female NPT (shipped with gas ballast port plug installed; 20 micron sintered filter provided)
Weight	Pump only: 9.5 kg (21 lbs.) Shipping weight: 10.5 kg (23 lbs.)
Leak rate	<1 x 10 ⁻⁶ std-cc/sec helium
Certification	Conforms with CE, CSA, CSA/CUS, Semi S2-703, and RoHS

NOTE: Scroll pumps are not suitable for pumping corrosive, explosive or particulate-forming gases.

DRY SCROLL PUMPS

IDP-3 Pumping Speed - Air/N₂

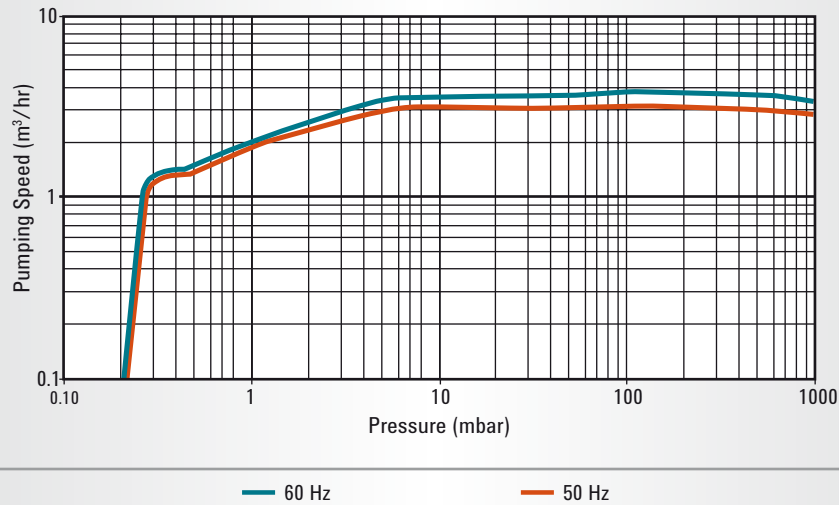

Ordering Information

Description	Part Number
IDP-3 dry vacuum pump, 1Ø, 220 V, 50/60 Hz	IDP3A01
IDP-3 dry vacuum pump, 1Ø, 115 V, 60 Hz	IDP3B01
IDP-3 dry vacuum pump, 1Ø, 100 V, 50/60 Hz	IDP3C01
IDP-3 dry vacuum pump, 24 VDC	IDP3D01

with Isolation Valve

IDP-3 dry vacuum pump with isolation valve, 1Ø, 220-230 V, 50/60 Hz	IDP3A21
IDP-3 dry vacuum pump with isolation valve, 1Ø, 115 V, 60 Hz	IDP3B21
IDP-3 dry vacuum pump with isolation valve, 1Ø, 100 V, 50/60 Hz	IDP3C21
IDP-3 dry vacuum pump with isolation valve, 24 VDC	IDP3D21

Power Cord Selection

Power Cord Selection	Part Number
Europe, 10 A / 220-230 V, 2.5 meter	656494220
Denmark, 10 A / 220-230 V, 2.5 meter	656494225
Switzerland, 10 A / 220-230 V, 2.5 meter	656494235
UK/Ireland, 13A / 230 V, 2.5 meter	656494250
India, 10 A / 220 - 250 V, 2.5 meter	656494245
Israel, 10 A / 230 V, 2.5 meter	656494230
Japan, 12 A/100 V, 2.3 meter	656494240
North America, 15 A / 125 V, 2.0 meter	656458203
North America, 10 A / 230 V, 2.5 meter	656494255

Accessories – Refer to the Scroll Accessories section beginning on page 27

Maintenance/Service Parts – Refer to the Scroll Service Parts section beginning on page 34

PUMP MODELS

▶ Agilent SH-110

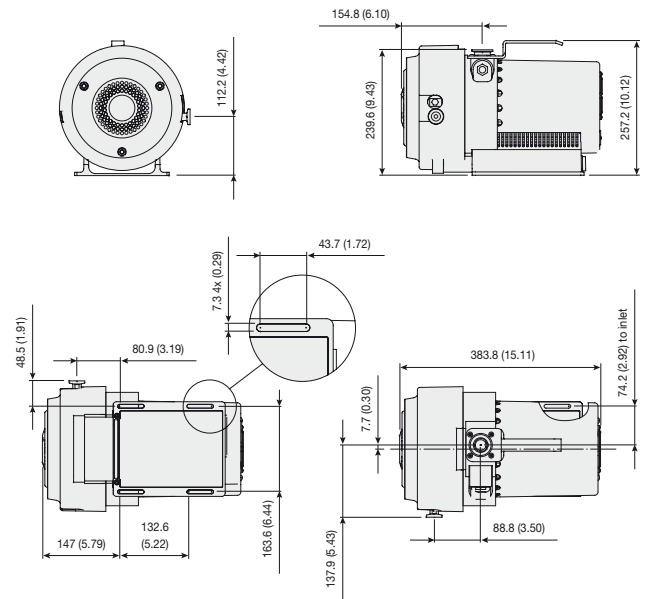

Dimensions: millimeters (inches)

The Agilent SH-110 is a dry, hermetic scroll pump that provides industry-leading features designed for easy integration into original-equipment manufacturer (OEM) systems. This single-stage pump produces a pumping speed of 110 l/m and achieves an ultimate pressure of 50 mTorr (0.07 mbar) in a compact package that is also ideally suited to end-user applications.

- Two-ply tip seal for improved base pressure performance
- Low-temperature operation
- ¼-horsepower motor for low power consumption
- Optional air ballast for effective handling of water vapor
- Built-in fail-safe isolation valve protects the vacuum system
- Universal 100-230 VAC power for easy installation worldwide
- Quick tip-seal replacement for low cost of ownership

Technical Specifications

Pumping speed	60 Hz: 110 l/m, 6.6 m ³ /hr, 4.0 cfm 50 Hz: 90 l/m, 5.4 m ³ /hr, 3.3 cfm
Ultimate pressure	6.6 x 10 ⁻² mbar (5.0 x 10 ⁻² Torr)
Maximum inlet pressure	1.0 atmosphere (0 psig)
Maximum outlet pressure	1.5 atmosphere (7.5 psig)
Inlet connection	NW25
Exhaust connection	¼" Female NPT (NW16 adapter provided)
Gas ballast	⅝" Female NPT (shipped with gas ballast port plug installed; 20 micron sintered filter provided)
Weight	Pump only: 19 kg (43 lbs) Shipping weight: 20 kg (44 lbs)
Leak rate (with exhaust sealed)	<1 x 10 ⁻⁷ cc/sec Helium
Certification	Conforms with CE, CSA, Semi S2-2000 and RoHS

NOTE: Scroll pumps are not suitable for pumping corrosive, explosive or particulate-forming gases.

DRY SCROLL PUMPS

SH-110 Pumping Speed - Air/N₂

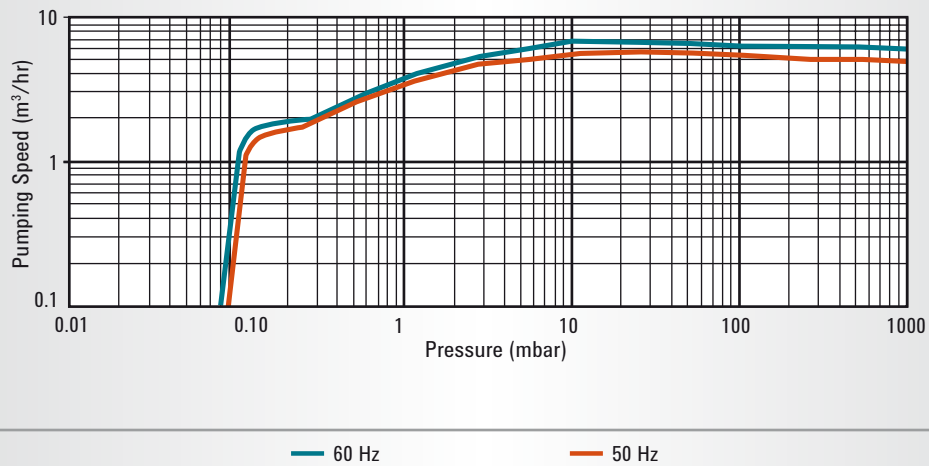

Ordering Information

Description	Part Number
SH-110 dry vacuum pump, 1Ø, 100 V - 230 V, 50/60 Hz	SH01101UNIV

Power Cord Selection	Part Number
Europe, 10 A / 220-230 V, 2.5 meter	656494220
Denmark, 10 A / 220-230 V, 2.5 meter	656494225
Switzerland, 10 A / 230 V, 2.5 meter	656494235
UK/Ireland, 13 A / 230 V, 2.5 meter	656494250
India, 10 A / 220-250 V, 2.5 meter	656494245
Israel, 10 A / 230 V, 2.5 meter	656494230
Japan, 12 A / 100 V, 2.3 meter	656494240
North America, 15 A / 125 V, 2.0 meter	656458203
North America, 10 A / 230 V, 2.5 meter	656494255

Accessories – Refer to the Scroll Accessories section beginning on page 27

Maintenance/Service Parts – Refer to the Scroll Service Parts section beginning on page 34

PUMP MODELS

▶ Agilent SH-112

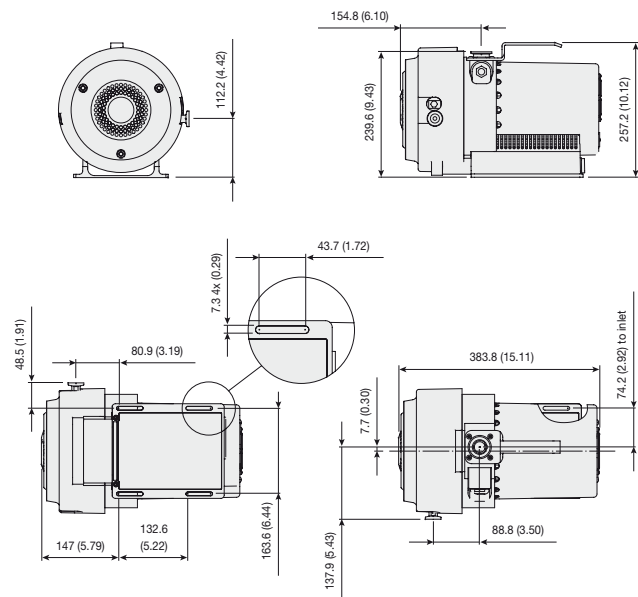

Dimensions: millimeters (inches)

The Agilent SH-112 is a dry, hermetic scroll pump that provides industry-leading features designed for easy integration into original-equipment manufacturer (OEM) systems. This single-stage pump produces a pumping speed of 110 l/m and achieves an ultimate pressure of 200 mTorr (0.26 mbar) in a compact package that is also ideally suited to end-user applications.

- Solid tip seals for extended service interval
- Low-temperature operation
- ¼-horsepower motor for low power consumption
- Optional air ballast for effective handling of water vapor
- Built-in fail-safe isolation valve protects the vacuum system
- Universal 100-230 VAC power for easy installation worldwide
- Quick tip-seal replacement for low cost of ownership

Technical Specifications

Pumping speed	60 Hz: 110 l/m, 6.6 m ³ /hr, 4.0 cfm 50 Hz: 90 l/m, 5.4 m ³ /hr, 3.3 cfm
Ultimate pressure	2.6 x 10 ⁻¹ mbar (2.0 x 10 ⁻¹ Torr)
Maximum inlet pressure	1.0 atmosphere (0 psig)
Maximum outlet pressure	1.5 atmosphere (7.5 psig)
Inlet connection	NW25
Exhaust connection	¼" Female NPT (NW16 adapter provided)
Gas ballast	⅝" Female NPT (shipped with gas ballast port plug installed; 20 micron sintered filter provided)
Weight	Pump only: 19 kg (43 lbs) Shipping weight: 20 kg (44 lbs)
Leak rate (with exhaust sealed)	<1 x 10 ⁻⁷ cc/sec Helium
Certification	Conforms with CE, CSA and RoHS

NOTE: Scroll pumps are not suitable for pumping corrosive, explosive or particulate-forming gases.

DRY SCROLL PUMPS

SH-112 Pumping Speed - Air/N₂

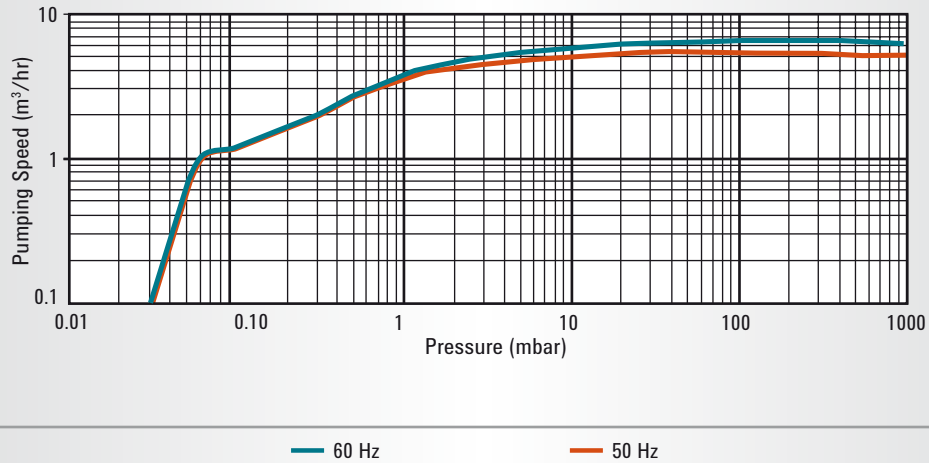

Dry Scroll
Pumps

Ordering Information

Description	Part Number
SH-112 dry vacuum pump, 1Ø, 100 V - 230 V, 50/60 Hz	SH01121UNIV

Power Cord Selection	Part Number
Europe, 10 A / 220-230 V, 2.5 meter	656494220
Denmark, 10 A / 220-230 V, 2.5 meter	656494225
Switzerland, 10 A / 230 V, 2.5 meter	656494235
UK/Ireland, 13 A / 230 V, 2.5 meter	656494250
India, 10 A / 220-250 V, 2.5 meter	656494245
Israel, 10 A / 230 V, 2.5 meter	656494230
Japan, 12 A / 100 V, 2.3 meter	656494240
North America, 15 A / 125 V, 2.0 meter	656458203
North America, 10 A / 230 V, 2.5 meter	656494255

Accessories – Refer to the Scroll Accessories section beginning on page 27

Maintenance/Service Parts – Refer to the Scroll Service Parts section beginning on page 34

PUMP MODELS

▶ Agilent IDP-15

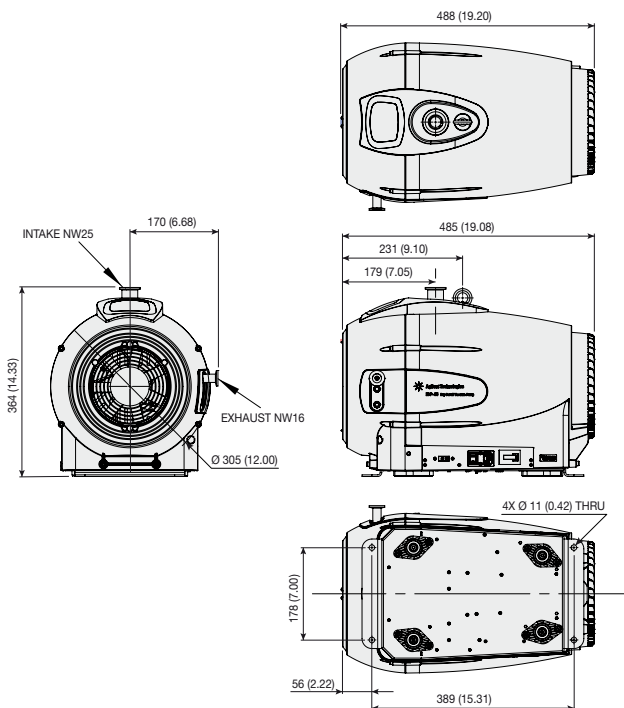

Dimensions: millimeters (inches)

The Agilent IDP-15 Scroll Pump is a high performance dry primary vacuum pump, providing rapid pump-down at 15.4 m³/hour (60 Hz). With a single-sided scroll design it offers fast, easy yearly maintenance and low cost of ownership. It is hermetic, with the motor and all bearings completely isolated from the vacuum path and protected from process gases for extended life.

The IDP-15 is exceptionally quiet (<50db) and vibration-free, and is ideal for use in Analytical Instrument and Research applications, and many industrial applications as well.

Technical Specifications

Pumping speed	60 Hz: 256 l/m, 15.4 m ³ /hr 50 Hz: 214 l/m, 12.8 m ³ /hr
Ultimate pressure	1.3 x 10 ⁻² mbar (1 x 10 ⁻² Torr)
Maximum inlet pressure	1.0 atmosphere (0 psig)
Maximum outlet pressure	6.5 psig
Inlet Connection	NW25
Exhaust Connection	NW16
Gas ballast	¼" Female NPT (two positions)
Weight	Pump only: 34 kg (75 lbs) Shipping weight: 45 kg (100 lbs)
Leak rate (with exhaust sealed)	<1 x 10 ⁻⁶ cc/sec Helium
Certification	Conforms with CE, CSA and RoHS

DRY SCROLL PUMPS

IDP-15 Pumping Speed - Air/N₂

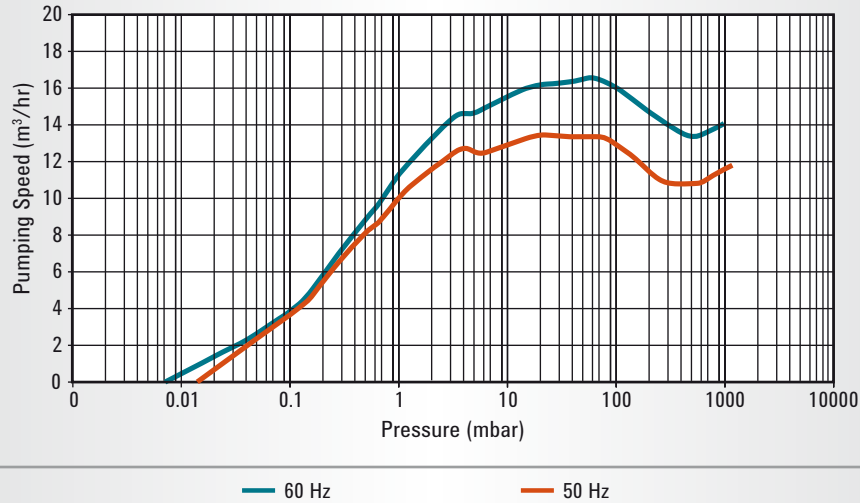

Ordering Information

Description	Part Number
IDP15 Scroll Pump, Std	X3815-64000
IDP15 Scroll Pump, Std w/inlt vlv	X3815-64010
Service	
IDP-15 Tip Seal Replacement Kit	X3815-67000
Spares	
Shipping Box Set, IDP-15	X3815-67001
Accessories – Refer to the Scroll Accessories section beginning on page 27	
Inlet Trap, NW25, HEPA	SCRINTRPNW25
Exhaust Silencer Kit, SH110	EXSLRSH110

Maintenance/Service Parts – Refer to the Scroll Service Parts section beginning on page 34

Line Cords	Part Number
Europe, 10A/220-230V, 2.5 meter	656494220
Denmark, 10A/220-230V, 2.5 meter	656494225
Switzerland, 10A/230V, 2.5 meter	656494235
UK/Ireland, 13A/230V, 2.5 meter	656494250
India, 10A/220-250V, 2.5 meter	656494245
Israel, 10A/220-230V, 2.5 meter	656494230
Japan, 12A/100V, 2.3 meter	656494240
North America, 15A/125V, 2.0 meter	656458203
North America, 10A/230V, 2.5 meter	656494255

PUMP MODELS

▶ Agilent TriScroll 300

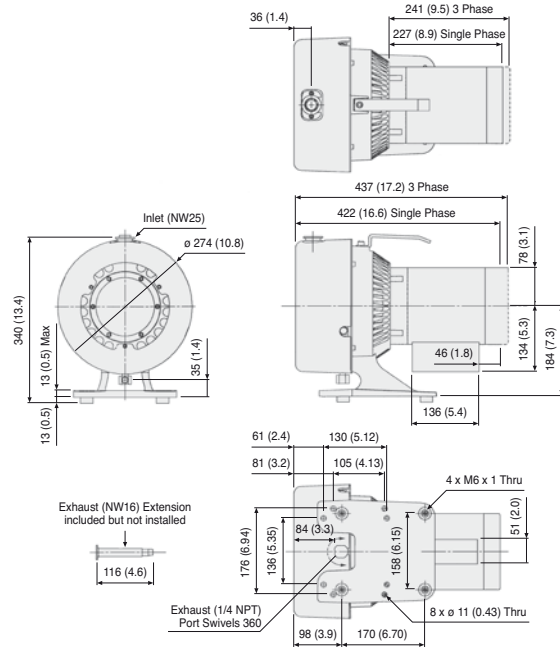

Dimensions: millimeters (inches)

The TriScroll series are two-stage dry scroll pumps that have high pumping speeds and low base pressure. TriScroll pumps eliminate the frequent maintenance requirements of oil-sealed rotary vane pumps, simplifying regulatory and environmental compliance, and eliminating oil disposal costs. The unique, patented TriScroll features proven reliability and durability, delivering consistent performance and superior cost of ownership.

- High pumping speed and low ultimate pressure provide clean, dry vacuum
- Long-life tip seals routinely last more than a year before replacement
- Bearing purge port permits simple maintenance and delivers long bearing life
- Automatic air ballast manages water vapor without reducing pumping speed

Technical Specifications

Pumping speed	60 Hz: 250 l/m, 15 m ³ /hr, 8.8 cfm 50 Hz: 210 l/m, 12.6 m ³ /hr, 7.4 cfm
Ultimate pressure	1.3 x 10 ⁻² mbar (1 x 10 ⁻² Torr)
Maximum inlet pressure	1.0 atmosphere (1.0 psig)
Maximum outlet pressure	1.1 atmosphere (1.5 psig)
Inlet connection	NW25
Exhaust connection	¼" Female NPT with swivel (NW16 adapter provided)
Gas ballast	⅝" Female NPT (shipped with 40 micron filter installed; port plug also provided)
Operating voltages	1Ø models: 50-60 Hz/100-115:200-230 VAC 3Ø models: 50 Hz/200-230, 380-415 VAC; 60 Hz/200-230, 460 VAC
Weight	Pump only: 26.4 kg (58 lbs) Shipping weight: 34.2 kg (75 lbs)
Certification	CE, CSA and RoHS

NOTE: Scroll pumps are not suitable for pumping corrosive, explosive or particulate-forming gases.

DRY SCROLL PUMPS

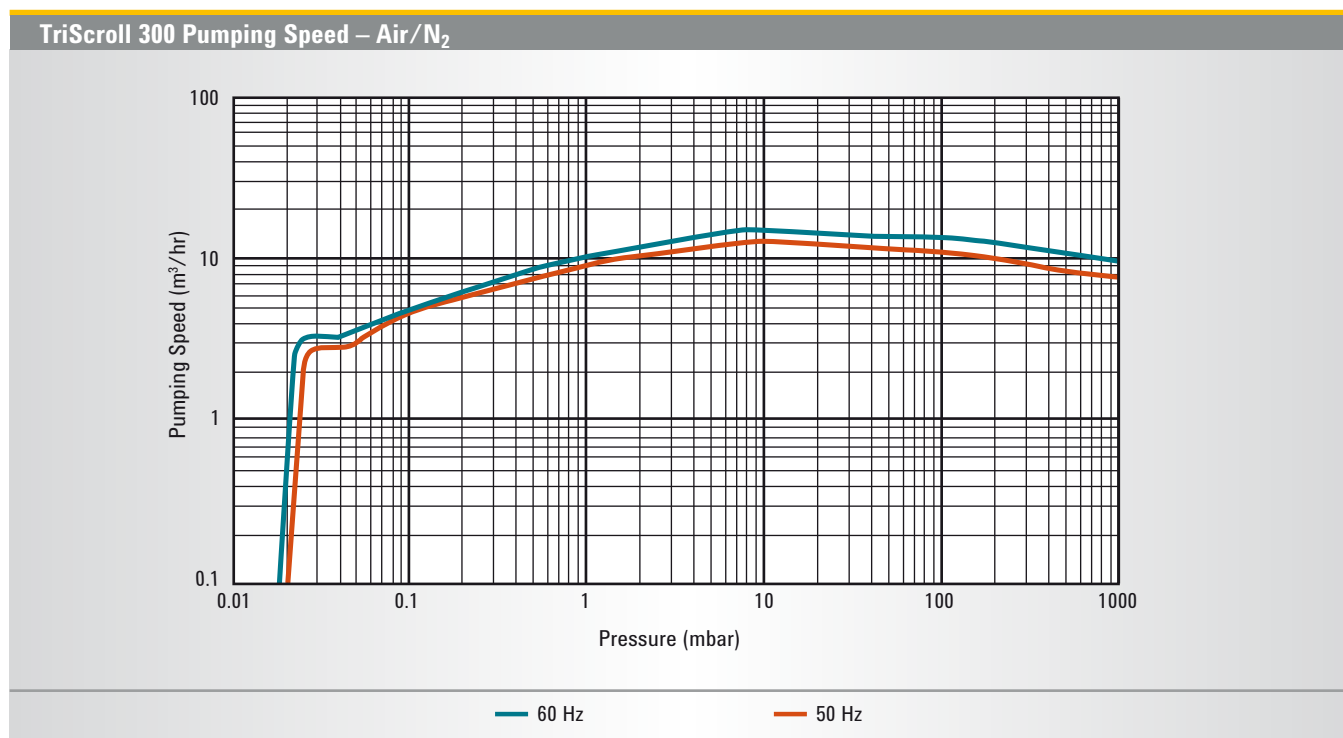

Ordering Information

Description	Part Number
TriScroll 300 dry vacuum pump, 1Ø motor, US cord	PTS03001UNIV
TriScroll 300 dry vacuum pump, 1Ø motor, Euro cord	PTS03001UNIVEU
TriScroll 300 dry vacuum pump, 1Ø motor, UK cord	PTS03001UNIVUK
TriScroll 300 dry vacuum pump, 3Ø motor	PTS03003UNIV
TriScroll 300, 1Ø, with vacuum isolation valve (VPI), 120 V	PTS03001UVPI*
TriScroll 300, 1Ø, with VPI, 220 V, EU power cord	PTS03001UVPIEU
TriScroll 300, 1Ø, with VPI, 220V, UK power cord	PTS03001UVPIUK
TriScroll 300, 3Ø, with VPI, 200 V	PTS03003200VPI
TriScroll 300, 3Ø, with VPI, 230 V	PTS03003230VPI
TriScroll 300, 3Ø, with VPI, 380/415 V	PTS03003380415VPI
TriScroll 300, 3Ø, with VPI, 460 V	PTS03003460VPI
TriScroll 300 exhaust extension	S4707002

* Contact Agilent for other voltages.

Accessories – Refer to the Scroll Accessories section beginning on page 27

Maintenance/Service Parts – Refer to the Scroll Service Parts section beginning on page 34

PUMP MODELS

▶ Agilent TriScroll 600

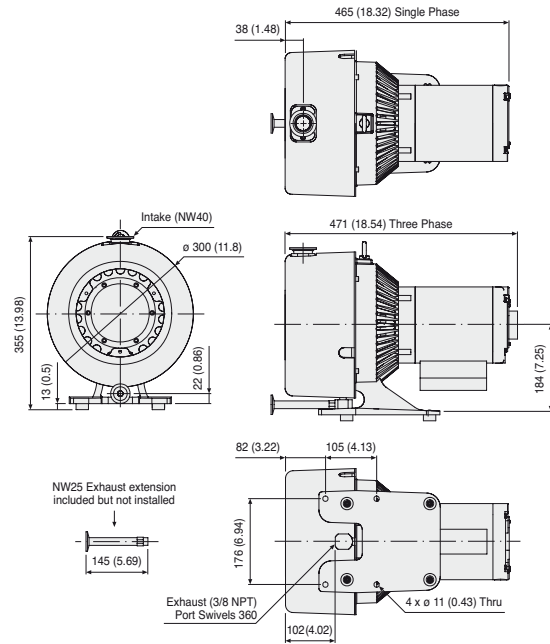

The TriScroll series are two-stage dry scroll pumps that have high pumping speeds and low base pressure. TriScroll pumps eliminate the frequent maintenance requirements of oil-sealed rotary vane pumps, simplifying regulatory and environmental compliance, and eliminating oil disposal costs. The unique, patented TriScroll features proven reliability and durability, delivering consistent performance and superior cost of ownership.

- High pumping speed and low ultimate pressure provide clean, dry vacuum
- Long-life tip seals routinely last more than a year before replacement
- Bearing purge port permits simple maintenance and delivers long bearing life
- Automatic air ballast manages water vapor without reducing pumping speed

Technical Specifications

Pumping speed	60 Hz: 500 l/m 30 m ³ /hr, 17.7 cfm 50 Hz: 420 l/m, 25.2 m ³ /hr, 14.8 cfm
Ultimate pressure	9.3 x 10 ⁻³ mbar (7.0 x 10 ⁻³ Torr)
Maximum inlet pressure	1.0 atmosphere (0 psig)
Maximum outlet pressure	1.1 atmosphere (1.5 psig)
Inlet connection	NW40
Exhaust connection	3/8" Female NPT with swivel (NW25 adapter provided)
Gas ballast	1/4" Female NPT (shipped with 40 micron filter installed; port plug also provided)
Operating voltages	1Ø models: 50-60 Hz/100-115, 200-230 VAC 3Ø models: 50 Hz/200-230, 380-415 VAC; 60 Hz/200-230, 460 VAC
Weight	Pump only: 32 kg (70 lbs) Shipping weight: 40 kg (87 lbs)
Certification	CE, CSA and RoHS

NOTE: Scroll pumps are not suitable for pumping corrosive, explosive or particulate-forming gases.

DRY SCROLL PUMPS

TriScroll 600 Pumping Speed – Air/N₂

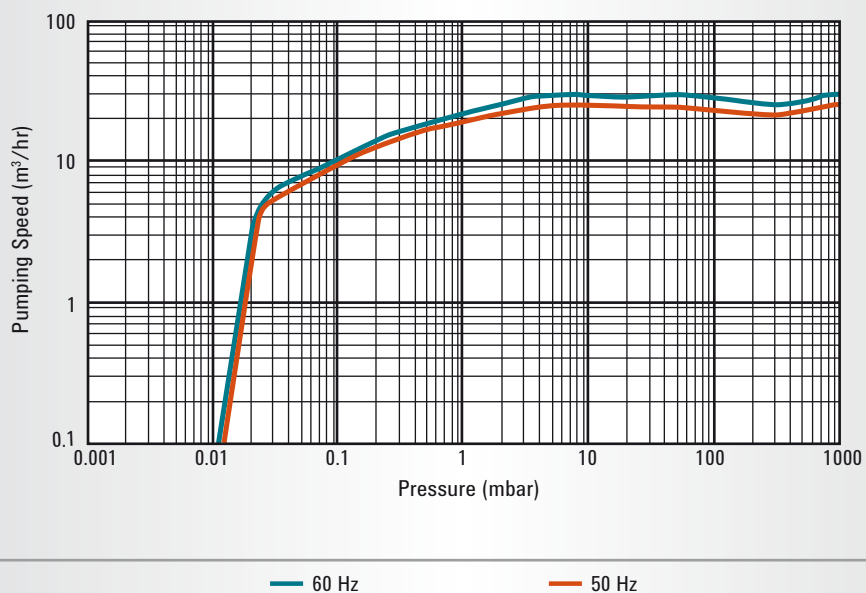

Ordering Information

Description	Part Number
TriScroll 600 dry vacuum pump, 1Ø motor	PTS06001UNIV
TriScroll 600 dry vacuum pump, 1Ø motor, Euro cord	PTS06001UNIVEU
TriScroll 600 dry vacuum pump, 1Ø motor, UK cord	PTS06001UNIVUK
TriScroll 600 dry vacuum pump, three phase motor	PTS06003UNIV
TriScroll 600, 1Ø, with vacuum isolation valve (VPI), 120 V	PTS06001UVPI*
TriScroll 600, 1Ø, with VPI, 220 V, EU power cord	PTS06001UVPIEU
TriScroll 600, 1Ø, with VPI, 220V, UK power cord	PTS06001UVPIUK
TriScroll 600, 3Ø, with VPI, 200 V	PTS06003200VPI
TriScroll 600, 3Ø, with VPI, 230 V	PTS06003230VPI
TriScroll 600, 3Ø, with VPI, 380 / 415 V	PTS06003380415VPI
TriScroll 600, 3Ø, with VPI, 460 V	PTS06003460VPI
TriScroll 600 exhaust extension	S4807001

* Contact Agilent for other voltages.

Accessories – Refer to the Scroll Accessories section beginning on page 27

Maintenance/Service Parts – Refer to the Scroll Service Parts section beginning on page 34

PUMP MODELS

▶ Agilent TriScroll 300 Inverter

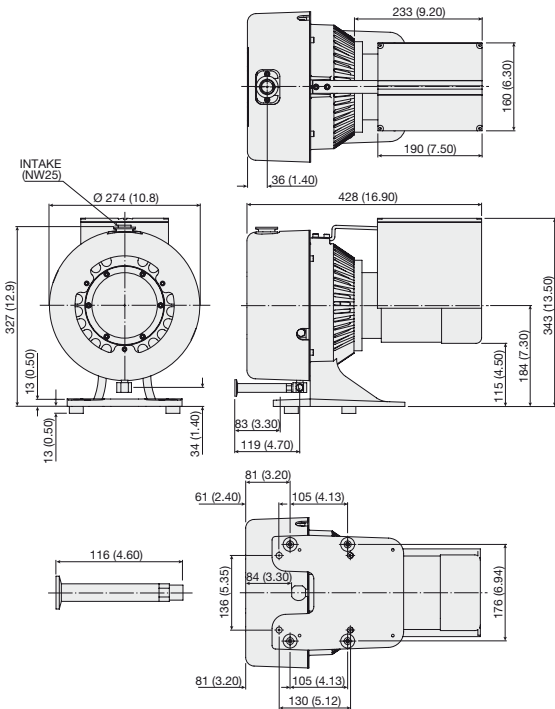

Dimensions: millimeters (inches)

TriScroll Inverter pumps apply the benefits of frequency inverter technology to the performance of Agilent TriScroll dry primary vacuum pumps. TriScroll Pumps eliminate the frequent maintenance requirements of oil-sealed rotary vane pumps, simplifying regulatory and environmental compliance, and eliminating oil disposal costs. Inverter-driven TriScroll 300 pumps also deliver:

- Constant pumping speed worldwide regardless of line frequency
- Optimal pumping speed selection by adjustment of the rotational speed of the pump via RS232 or 0–10 V control signal
- Monitoring of pump parameters via serial interface
- Remote start/stop with a contact closure made possible by a standard D-shell connector
- Optimal rotational speed selection reduces noise and vibration levels in the work area with little loss in base pressure performance of the pump

Technical Specifications

Pumping speed @ 60 Hz	250 l/m, 15 m ³ /hr, 8.8 cfm (at 60 Hz drive frequency, variable)
Ultimate pressure	1.3 x 10 ⁻² mbar (1.0 x 10 ⁻² Torr)
Maximum inlet pressure	1.0 atmosphere (0 psig)
Maximum outlet pressure	1.1 atmosphere (1.5 psig)
Inlet connection	NW25
Exhaust connection	¼" Female NPT with swivel (NW16 adapter provided)
Gas ballast	¼" Female NPT (shipped with 40 micron filter installed; port plug also provided)
Operating voltages	100-115 V, 200-240 V, 1Ø, 50/60 Hz
Maximum line current	200 V; 5 A 240 V; 4.2 A
Weight	Pump only: 26 kg (57 lbs) Shipping weight: 34 kg (74 lbs)
Certification	CE, CSA and RoHS

NOTE: Scroll pumps are not suitable for pumping corrosive, explosive or particulate-forming gases.

DRY SCROLL PUMPS

TriScroll 300 Inverter Pumping Speed – Air/N₂

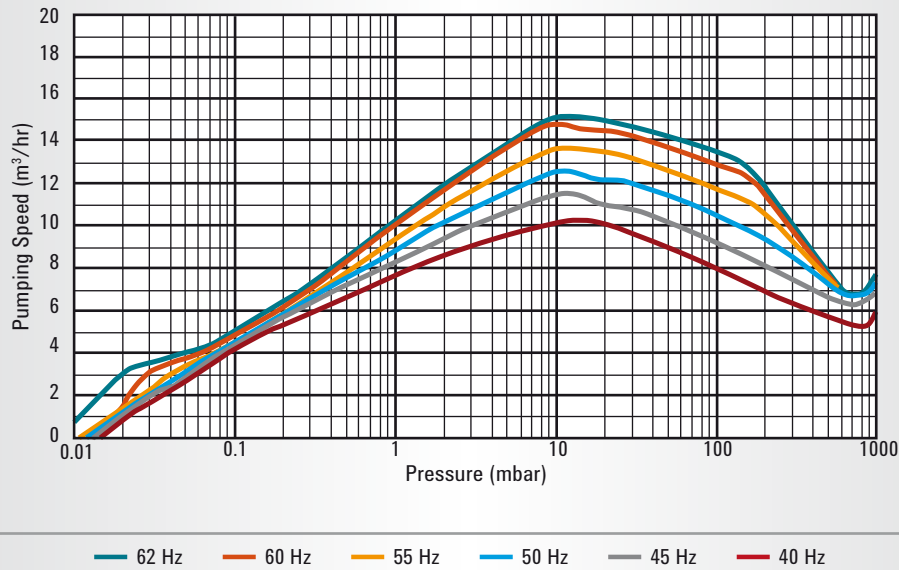

Dry Scroll Pumps

Ordering Information

Description	Part Number
TriScroll 300 dry vacuum pump, 1Ø motor, 100-240 V	PTS03001INV
Power Cord Selection	Part Number
Europe, 10 A / 220-230 V, 2.5 meter	656494220
Denmark, 10 A / 220-230 V, 2.5 meter	656494225
Switzerland, 10 A / 230 V, 2.5 meter	656494235
UK/Ireland, 13 A / 230 V, 2.5 meter	656494250
India, 10 A / 220-250 V, 2.5 meter	656494245
Israel, 10 A / 220-230 V, 2.5 meter	656494230
Japan, 12 A / 100 V, 2.3 meter	656494240
North America, 15 A / 125 V, 2.0 meter	656458203
North America, 10 A / 230 V, 2.5 meter	656494255

Accessories – Refer to the Scroll Accessories section beginning on page 27

Maintenance/Service Parts – Refer to the Scroll Service Parts section beginning on page 34

PUMP MODELS

▶ Agilent TriScroll 600 Inverter

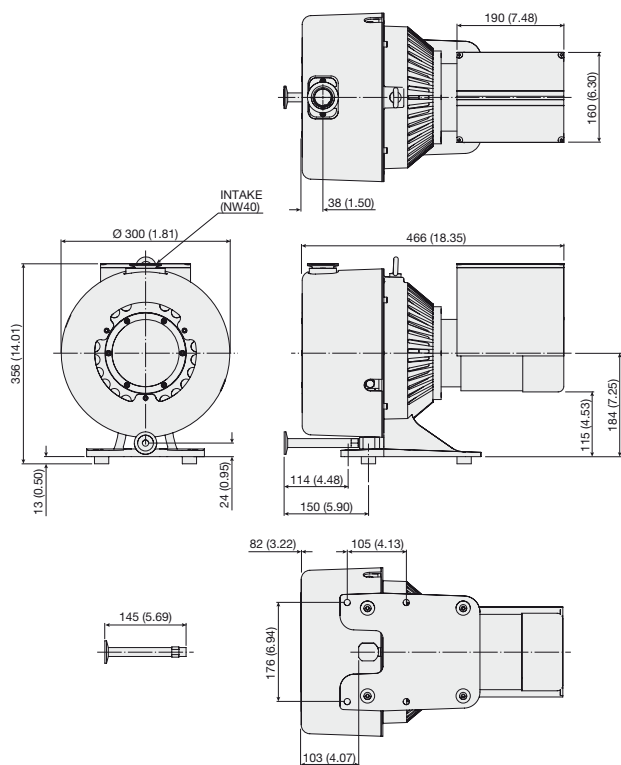

Dimensions: millimeters (inches)

TriScroll Inverter pumps apply the benefits of frequency inverter technology to the performance of Agilent TriScroll dry primary vacuum pumps. TriScroll Pumps eliminate the frequent maintenance requirements of oil-sealed rotary vane pumps, simplifying regulatory and environmental compliance, and eliminating oil disposal costs. Inverter-driven TriScroll 600 pumps also deliver:

- Constant pumping speed worldwide regardless of line frequency
- Optimal pumping speed selection by adjustment of the rotational speed of the pump via RS232 or 0–10V control signal
- Monitoring of pump parameters via serial interface
- Remote start/stop with a contact closure made possible by a standard D-shell connector
- Optimal rotational speed selection reduces noise and vibration levels in the work area with little loss in base pressure performance of the pump

Technical Specifications

Pumping speed @ 60 Hz	500 l/m, 30 m ³ /hr, 17.7 cfm (at 60 Hz drive frequency, variable)
Ultimate pressure	9.3 x 10 ⁻³ mbar (7.0 x 10 ⁻³ Torr)
Maximum inlet pressure	1.0 atmosphere (0 psig)
Maximum outlet pressure	1.1 atmosphere (1.5 psig)
Inlet connection	NW40
Exhaust connection	3/8" Female NPT with swivel (NW25 adapter provided)
Gas ballast	1/4" Female NPT (shipped with 40 micron filter installed; port plug also provided)
Operating voltages	200-240 V, 1 ϕ , 50/60 Hz
Maximum line current	200 V; 5 A 240 V; 4.2 A
Weight	Pump only: 31 kg (68 lbs) Shipping weight: 39 kg (85 lbs)
Certification	CE, CSA and RoHS

NOTE: Scroll pumps are not suitable for pumping corrosive, explosive or particulate-forming gases.

DRY SCROLL PUMPS

TriScroll 600 Inverter Pumping Speed – Air/N₂

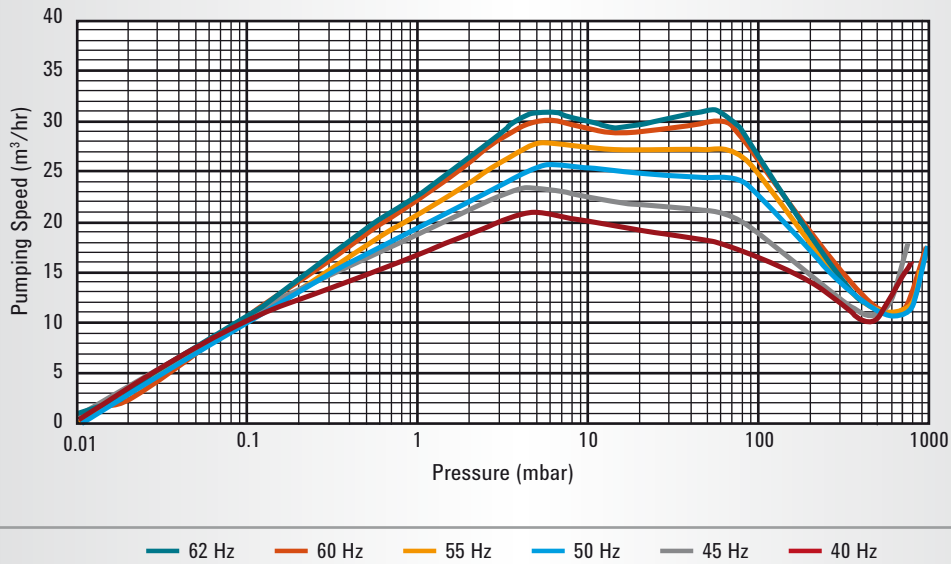

Dry Scroll Pumps

Ordering Information

Description	Part Number
TriScroll 600 dry vacuum pump, 1Ø, 200-240 V	PTS06001INV
Power Cord Selection	Part Number
Europe, 10 A / 220-230 V, 2.5 meter	656494220
Denmark, 10 A / 220-230 V, 2.5 meter	656494225
Switzerland, 10 A / 230 V, 2.5 meter	656494235
UK/Ireland, 13 A / 230 V, 2.5 meter	656494250
India, 10 A / 220-250 V, 2.5 meter	656494245
Israel, 10 A / 230 V, 2.5 meter	656494230
North America, 10 A / 230 V, 2.5 meter	656494255

Accessories – Refer to the Scroll Accessories section beginning on page 27

Maintenance/Service Parts – Refer to the Scroll Service Parts section beginning on page 34

ABOUT FREQUENCY INVERTER-DRIVEN SCROLL PUMPS

The application of innovative variable frequency inverter technology to Dry Scroll Pumps provides significant advantages over conventional vacuum pumps. Inverter-driven TriScroll 300, 600 and IDP-15 pumps deliver optimal and consistent performance throughout the worldwide range of voltage and frequency conditions. Operating with low power requirements, the microprocessor-controlled frequency inverter is an efficient driving unit capable of delivering high starting torque and constant pump performance.



I/O and RS232/RS485 Communication

Adjustable motor speed from 35 to 65 Hz permits easy matching of pumping speed required and reduces noise levels. Pump performance can be tailored to specific applications to optimize system performance.



Universal Input Voltage

Truly universal single-phase voltage and frequency provide worldwide compatibility and constant performance at different input frequencies.

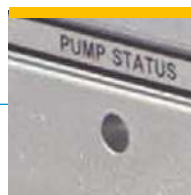

Remote Diagnostics

Fully compatible with Agilent TPlus Software, the RS232/485 interface allows data acquisition and control of the pump operation, including pumping speed.



Reduced Power Requirements

Inverter technology reduces the power required compared to traditional single phase motors.

▶ **HEPA Inlet Filters**

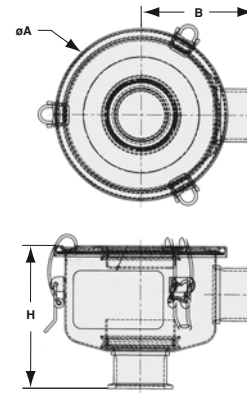

Agilent Inlet HEPA filters for scroll pumps protect the pump from ingested particles and prevent particles from migrating out of the pump. These HEPA filters trap particles > 0.3 microns at a rated 99.97% efficiency.

	NW16	NW25	NW40
A	95.25 (3.75)	146.05 (5.75)	146.05 (5.75)
H	99.06 (3.90)	111.00 (4.37)	120.90 (4.76)
B	66.17 (2.61)	185.85 (3.38)	195.76 (3.77)

Ordering Information

Description	Part Number
NW40 inlet trap with HEPA filter insert	SCRINTRPNW40
NW25 inlet trap with HEPA filter insert	SCRINTRPNW25
NW16 inlet trap with HEPA filter insert	SCRINTRPNW16
Replacement HEPA filter element (NW25 or NW40)	REPLHEPAFILTER1
Replacement HEPA filter element (NW16)	REPLHEPAFILTER2

Dry Scroll Pumps

▶ **Exhaust Filter Kits for TriScroll Pumps**

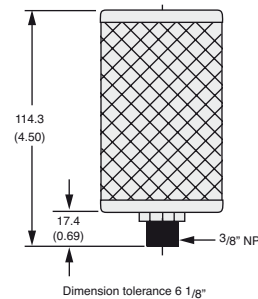

These HEPA filters trap particles and dust that emanate from the vacuum system and prevent discharge into the room. Kits include one HEPA filter, flange adapter, centering ring seal, and clamp to fit the exhaust extensions. These HEPA filters trap particles > 0.3 microns at a rated 99.97% efficiency. Replacement filters are also available.

Ordering Information

Description	Part Number
Exhaust filter kit, TriScroll 300	PTS300EXFIL
Exhaust filter kit, TriScroll 600	PTS600EXFIL
Replacement HEPA filter	110420110

SCROLL ACCESSORIES

▶ Exhaust Silencer Kits

Exhaust Silencer Kits are designed for those applications in which it is desirable to diminish the sound level produced by the work of gas compression.

An exhaust silencer is not necessary in situations where exhaust is carried away in a ducted manifold, because in that case, the noise level is typically at the same level as when a local silencer is used.

Exhaust Silencers work by breaking up noise pulsation in the discharge line. The kits contain two basic components, as well as installation hardware.

1. The exhaust/muffler filter provides the majority of the actual noise reduction.
2. An optional silencer can be connected to the exhaust of the pump as well. It attenuates certain frequencies associated with the exhaust gas pulsation noise. The silencer is then plumbed to the exhaust muffler.



Ordering Information

Description	Part Number
Exhaust silencer kit for IDP-3	EXSLRIDP3
Exhaust silencer kit for SH-110/SH-112/IDP-15	EXSLRSH110
Exhaust silencer kit for TriScroll	EXSLRTRISCROLL
Replacement Filter Element	
for IDP-3 Silencer	REPLSLRFILTER2
for SH-110/SH-112/IDP-15 Silencer	REPLSLRFILTER1
for TriScroll Silencer	REPLSLRFILTER

DRY SCROLL PUMPS

▶ Vibration Isolation Kits

Vibration Isolation Kits are designed to reduce the vibration level transmitted at the base of the scroll pump. The set of vibration isolation mounts provided in the kit will be most beneficial in those applications that require minimal vibration transmission from the pump to the installation. The isolation mounts replace the standard feet installed on the pump and can be used alone or with flexible bellows at the pump inlet to enhance pump isolation.

Please note, the mounts will increase the height of the TriScroll pumps by 0.75 inches compared to the standard mounting feet supplied with the pump.



Ordering Information

Description	Part Number
Vibration isolation kit for IDP-3	IDP3VIBISOKIT
Vibration isolation kit for SH-110/SH-112	SH110VIBISOKIT
Vibration isolation kit for TriScroll	PTSVIBISOKIT

NOTE: IDP-15 has integral vibration isolation, which is standard.

SCROLL ACCESSORIES

► Purge Kits for TriScroll Pumps

This kit enables safe, proper purging of either the main bearings through the TriScroll bearing purge port, or the pump exhaust region through the gas ballast port.

Use of a gas ballast purge is indicated where it is desirable to dilute the pumped gases, and is always recommended when pumping condensable gases.

The kit includes a flow meter with manual throttle valve, a 5-psig relief valve, necessary tubing and fittings, and instructions. The flow meter assembly mounts directly onto the TriScroll pump. The recommended flow rate for both the gas ballast and bearing purge port is 5 liters/minute.

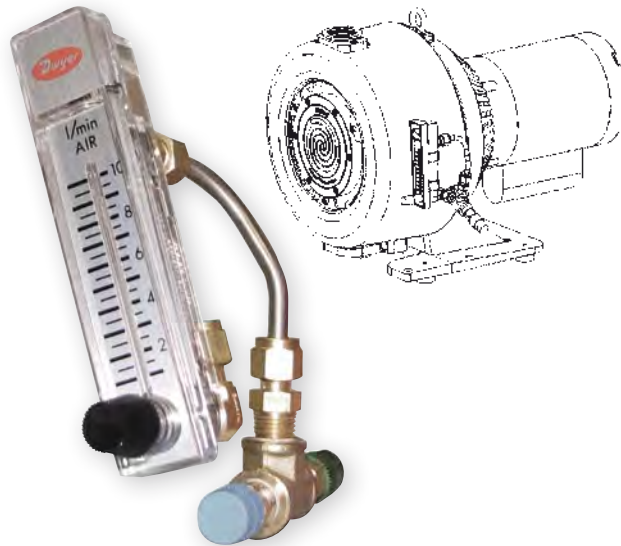

Ordering Information

Description

Purge kit for TriScrolls

Part Number

PTSPURGEKIT

DRY SCROLL PUMPS

Agilent offers a range of isolation valves that are used with the scroll pump to ensure proper vacuum isolation and eliminate turbulence into the pump foreline.

For applications where the process is sensitive to particulate or requires the best vacuum isolation, the installation of a fast acting, automatic, normally closed valve is recommended to maintain vacuum and prevent backstreaming of debris which may have accumulated inside the pump.

Vacuum Isolation Valve – SH-110/SH-112



▶ Vacuum Isolation Valves for Scroll Pumps

The SH-110 and SH-112 have an integral solenoid valve at the inlet that provides isolation of the pump in case of power failure and when shut off. At restart there is a 10 second time delay before the valve opens. This time allows a good level of vacuum to be established between the valve and the pump before the pump is exposed to the system vacuum line. This eliminates turbulence that can cause back migration of particulate.

Isolation Valve Retrofit Kits are available for the IDP-3. These kits employ the same valve as used on the SH Series and operate as described above.

Vacuum Isolation Valve – IDP Series



Dry Scroll Pumps

Ordering Information

Description	Part Number
Isolation valve retrofit kit for IDP series, 200 VAC	VPI16IDP220
Isolation valve retrofit kit for IDP series, 115 VAC	VPI16IDP115
Isolation valve retrofit kit for IDP series, 100 VAC	VPI16IDP100

NOTE: A Vacuum Isolation Valve is a standard option for IDP-15.

SCROLL ACCESSORIES

▶ Agilent Vacuum Pump Isolation Valve (VPI)

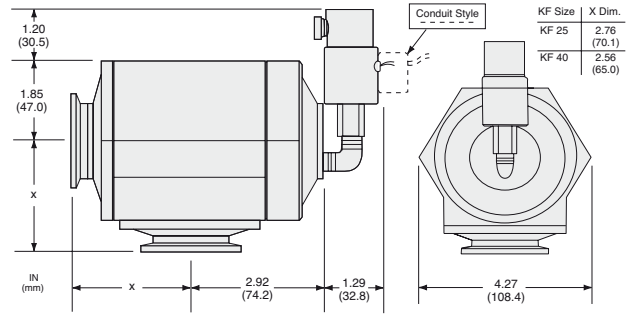

Dimensions: inches (millimeters)

Protection for Your Vacuum System

The VPI is electrically connected in parallel with your mechanical pump, and closes rapidly when power is interrupted to prevent oil backstreaming or particle migration into your vacuum system. The valves also vent the pump from the inlet side to push any debris towards the outlet, thereby preventing it from being swept into the system when pumping is restarted. The body design and right-angle configuration provide maximum conductance.

Technical Specifications

Materials	Body: 6061-T6 aluminum Piston: 2024 aluminum Seals: viton
Leak rate	Body and seal: $<1 \times 10^{-9}$ std cc/sec He
Closing time	<30 milliseconds
Power	7 watts @ 115 VAC
Conductance	NW25 - 13 l/s NW40 - 33 l/s
Temperature range	Valve: 0 ° to 100 °C, Solenoid 0 ° to 50 °C

Features

- Lock-over-center mechanism
- Fast-acting: valve closes in less than 30 milliseconds
- Provides venting of the pump at the pump inlet
- Remains closed until pump inlet pressure returns to system pressure
- Operates with atmospheric pressure and is activated upon loss of electrical power
- Provides maximum conductance

Benefits

- Reliable, repeatable seals
- Immediate protection of your vacuum system from oil or contaminant migration in the event of power failure
- Flow direction is maintained; oil/debris are not swept into the system
- Continued protection and easy restart
- No compressed air required for operation
- No reduction of pumping speed

DRY SCROLL PUMPS

Ordering Information

Description	Voltage	Part Number	Shipping Weight lbs. (kg)
NW25	120 VAC	VPI251205060	5 (2.3)
	133 VAC	VPI251335060	5.0 2.3
	220 VAC	VPI252205060	5.0 2.3
	266 VAC	VPI252665060	5.0 2.3
NW40	120 VAC	VPI401205060	5.0 2.3
	133 VAC	VPI401335060	5.0 2.3
	220 VAC	VPI402205060	5.0 2.3
	266 VAC	VPI402665060	5.0 2.3
Accessories			
Piston Kit, NW25		VPI25PSTNKIT	1.0 (0.5)
Rebuild Kit, NW25		VPI25RBLDKIT	1.0 (0.5)
Piston Kit, NW40		VPI40PSTNKIT	1.0 (0.5)
Rebuild Kit, NW40		VPI40RBLDKIT	1.0 (0.5)
Replacement Solenoid	120 VAC	VPISOL1205060	1.0 (0.5)
	133 VAC	VPISOL1335060	1.0 (0.5)
	220 VAC	VPISOL2205060	1.0 (0.5)
	266 VAC	VPISOL2665060	1.0 (0.5)
Seals Kit, NW25/40		VPISEALSKIT	1.0 (0.5)

SCROLL PUMP SERVICE AND SUPPORT PLANS

Agilent's service and support offering is one of the most comprehensive in the industry with an emphasis on quick response time and hassle-free service. The following pages detail the standard sections of our Scroll Pump Service and Support Plan. For more information, or if you have a need for customized solutions, please contact your Agilent representative.

- Product Support**
 - Technical Assistance**
- **Exchange/Repair Program**
 - **Upgrade Program**
 - **Extended Warranty**
 - **Cleaning Service**
 - **Worldwide Sourcing**
 - **Customer Support**
 - **Application Support**
 - **Application Training**

Product Support

Exchange/Repair Program

The Exchange Program maximizes uptime for those occasions where fast response is essential, offering exchange units for advance shipment. Our exchange units are fully reconditioned to the same strict standards as new products. They are kept in stock in North America, Europe, Japan, Korea, Singapore and Taiwan. If requested, your exchange unit can be shipped for overnight delivery.

The Repair Program is available for those situations where the traceability of assets is important and when the customer must retain possession of the original pump.

Both the Exchange and Repair Programs are available worldwide and provide global OEMs and end-users consistent delivery time, value pricing, and simple order processing procedures.

To order an exchange unit, add the letters "EX" before the product part number you need to exchange. After receipt of the exchange unit, you have up to 20 days to return the original unit to Agilent.

To request repair of your unit, contact the closest Agilent location.

Upgrade Program

The Upgrade Program is designed for customers who need to replace a Agilent product at the end of its life, or wish to upgrade to the newer technology of a more current product. For example, a customer might wish to replace a TriScroll 300 scroll pump with the newer TriScroll 300 inverter scroll pump with the more advanced inverter technology.

The Upgrade Program includes proactive technical installation support by telephone and full 12-month warranty.

Technical Assistance

Customer Support

Our toll-free lines with mother tongue technical support engineers at worldwide locations, allow us to provide you with quick, corrective responses to your needs. When a new problem is identified and solved by our support personnel, it is entered into our technical support system and becomes available to our network of Agilent technical support centers.

This system allows all Agilent locations to provide excellent first and second level technical support to customers worldwide.

In addition, the technical support centers are in daily contact with our R&D departments for a third level support.

Application Support - Application Training

Agilent has a leadership position in vacuum technology and maintains this position by continuously search for innovative solutions through research and development. To meet the most demanding needs, our application engineering team can bring our knowledge into your factory.

Application Support is a project-based activity where our experts assist you towards the solution of your application issues that might arise pre-sales or post-sales. By designing solutions that meet customer needs, Agilent aims to create a positive and synergetic relationship with customers. Our experts can keep you well informed and up-to-date on industrial and scientific applications with the goal of optimizing the use of our products on your system as well as the development of new vacuum techniques.

For more information, or if you have a need for customized solutions, please contact your Agilent representative.

DRY SCROLL PUMPS

Agilent's industry leading service programs maximize your system uptime and productivity.

Agilent offers several scroll pump service and maintenance options depending on your in-house capability and maintenance approach. From “do it yourself” to exchange of the entire pump, we accommodate your maintenance needs.

Routine maintenance of Agilent scroll pumps consists of simple tip seal replacement. The IDP and SH Series pumps require only the tip seal kit and common tools for tip seal replacement; for TriScroll pumps a tip seal tool kit is recommended along with the replacement tip seal kit.

Major maintenance involves bearing and seals replacement in addition to tip seal replacement and is required much less frequently. Major maintenance on the TriScroll 300 and TriScroll 600 pumps is most frequently accomplished

through Agilent’s advance exchange program where the used scroll module is exchanged with a factory rebuilt module. Alternatively, a new replacement scroll module may be installed, or the maintenance on the TriScroll pumps can even be accomplished on-site by qualified personnel.

Major maintenance kits contain all bearings, bearing seals, bearing lubricant, o-rings and tip seals required to rebuild TriScroll pumps. Maintenance tool kits are also available and contain all fixtures and tools required to perform any maintenance on TriScroll pumps.

Major maintenance of the SH Series is done through Agilent’s Advance Exchange program to exchange the entire pump. Your IDP-3 is maintained using a replacement scroll module.

For many models of Agilent’s scroll pumps, advance exchange of the entire pump is available.

Ordering Information

Description	Part Number
IDP-3	
Tip seal kit	IDP3TS
Replacement module	IDP3
IDP-15	
Tip seal replacement kit	X3815-67000
SH-110/SH-112/SH-100	
Tip seal replacement kit, SH-110/100	SH0110TS
Tip seal replacement kit, SH-112	SH0112TS
TriScroll 300/600 and TriScroll Inverter Pumps	
TriScroll 300 exhaust extension	S4707002
TriScroll 300 maintenance kit	PTSS0300MK
TriScroll 600 maintenance kit	PTSS0600MK
TriScroll 300/600 maintenance tool kit	PTSS0600TK
TriScroll 300 replacement tip seal kit	PTSS0300TS
TriScroll 600 replacement tip seal kit	PTSS0600TS
TriScroll 300/600 tip seal tool kit	PTSTSTKIT
TriScroll 300/600 three phase cable kit	S478900
Exchange and Replacement Pumps	
Exchange SH-110 scroll pump	EXSH01101UNIV
Exchange TriScroll 300 pump module	EXPTS0300SC
Replacement TriScroll 300 pump module	S4700304
Exchange TriScroll 600 pump module	EXPTS0600SC
Replacement TriScroll 600 pump module	S4800304
Exchange TriScroll 300 pump 300 pump, 1Ø	EXPPTS03001
Exchange TriScroll 300 pump 300 pump, 3Ø	EXPPTS03003
Exchange TriScroll 300 pump 600 pump, 1Ø	EXPPTS06001
Exchange TriScroll 300 pump 600 pump, 3Ø	EXPPTS06003



AGILENT DIFFUSION PUMPS

2-3	Features and Benefits
4-5	Typical Applications
6-29	Pump Models
30	Fluids
31	Baffles
32-35	Technical Notes



Agilent Technologies

DIFFUSION PUMPS FEATURES AND BENEFITS

Agilent has earned its position as the leading diffusion pump manufacturer in the world by listening to customer needs and by continuously improving the performance and reliability of our benchmark designs. Throughout our more than forty years of leadership in the industry, we have consistently produced pumps that provide the most efficient means of converting heat into pumping throughput. Our experience has allowed us to optimize the design of every element of the pump. As a result, Agilent diffusion pumps offer you the lowest cost of ownership available for many high vacuum-pumping applications.



Low Cost of Ownership

By providing the highest throughput available per unit of power, reduced cooling water requirements, and rugged, durable construction, Agilent delivers large volume pumping at the lowest total cost to you.

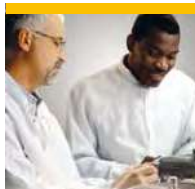

World-class Service, Training and Support

Agilent's application consulting capability makes use of our unparalleled experience to identify the optimal solution for you. And we invite you to take advantage of our industry leading worldwide service and support programs and award winning vacuum training classes to maximize system uptime and productivity.



Options to Address Your Needs

Many applications have unique requirements. Agilent can provide additional features such as Halo or custom baffles to eliminate additional backstreaming, and a Quick Cool Coil option to accelerate system cycle times.

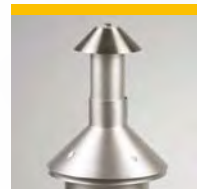

Fully Optimized Jet

Using our long and varied experience Agilent designs and produces vapor jets that deliver the highest throughput, pressure stability, and tolerable foreline pressure available, while reducing backstreaming to a minimum.

DIFFUSION PUMPS

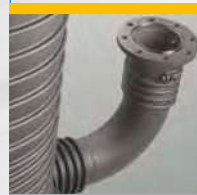

Built for Production Volumes

Our success is in helping you meet the exacting requirements of your production process.

Our pumps deliver superior pumping at high pressure and high gas flow conditions, and handle gas load variations that are typical of large volume production.



Easy to Maintain

Maintaining uptime is critical so we have simplified operation and maintenance. A sight glass provides visual indication of status when cold or hot and under vacuum. A gauge port facilitates system troubleshooting.

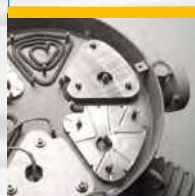

Robust Boiler Design

Through optimized boiler design, Agilent pumps are stable and reliable under widely varying operating conditions. This temperature stability prolongs fluid life as well. Thermal protection switches prevent system over-temperature conditions.

TYPICAL APPLICATIONS



Courtesy of Mill Lane Engineering

As the worldwide diffusion pump market leader, Agilent produces the most comprehensive family of pumps, ranging from 2 in. to 35 in. in diameter, and is the only broad-line, U.S.-based manufacturer.

The diffusion pump is the most common type of pump for use in high vacuum applications. These vapor jet pumps are one of the oldest and most reliable ways to create a vacuum. Since the chamber itself has no moving parts aside from the oil droplets, a vacuum diffusion pump can operate with stability over long periods.

In all diffusion pumps, a small amount of backstreaming occurs. Backstreaming is the migration of minute levels of oil that move in the opposite direction— toward the inlet of the pump and into the process stream, which may be the stage of an electron microscope or a welding chamber. In some applications, minor backstreaming has no impact; in others, where the purity of materials is critical, backstreaming cannot be tolerated. For this reason, systems typically add an optically dense baffle of varying design to deflect oil particles before they can reach the process stream.



Courtesy of Materials Research Furnaces, Inc.

Diffusion pumps are in wide use because they have several advantages: They are reliable, simple in design, operate without noise or vibration, and are relatively inexpensive to operate and maintain. In fact, diffusion pumping is still the most economical means of creating high-vacuum environments. These pumps also tolerate operating conditions such as excess particles and reactive gases that would destroy other types of high-vacuum pumps.

With the proper choice of motive fluids, traps, baffles, and valves, diffusion pumps can be used in a wide variety of applications and over pressure ranges from 1×10^{-3} Torr to 2×10^{-11} Torr

Key features of Agilent diffusion pumps include:

- High pumping speeds
- High throughput
- High forepressure tolerance
- Low ultimate pressure
- Excellent backstreaming characteristics
- Long-term reliability

DIFFUSION PUMPS



Vacuum Furnaces

Vacuum furnace applications require pumps that are capable of achieving stable pressures in high gas flow environments. Additionally, furnace operators need shorter cycle times to accomplish efficient processing of heat-treated material batches.

Furnace operators derive these benefits from Agilent vapor diffusion pumps, because the high throughput and low backstreaming rates of the pumps accommodate high material outgassing and allow higher cross-over pressures for shorter cycle times.

Metallizing

In web and roll coating systems, Agilent diffusion pumps have the ability to pump high gas loads making them the perfect choice for continuous production applications.

Large Area Coating/Thin Film Deposition

Due to its simplicity, high performance and low initial costs, the diffusion pump remains a primary pumping mechanism

for large area coating systems. The large pumps used in this application come equipped with sight glass and drain assemblies and are also available with ASA or ISO flanges.

Coatings (Optical, Electronics, Protective)

With low ultimate pressure, high speed, high throughput and high tolerable forepressure, Agilent diffusion pumps are the best choice for developmental and production systems.

Molecular Beams

The foreline ejector stage provides high tolerable forepressure and a large surface area for efficient degassing of compressed fluid, while the foreline baffle minimizes fluid loss even under high throughput conditions.

All Agilent pumps incorporate an ejector stage as well as full fractionating jets. HS series pumps create high speed and low ultimate pressure, high throughput and high tolerable forepressure and low backstreaming combine to make the HS series the best diffusion pump. Additionally, pumps are equipped with full thermal protection.

PUMP SPECIFICATIONS

	AX-65	HS-2	VHS-4	VHS-6
Previous model number		0160	0183	0184
Pumping speed*, l/s (operating range)				
Air	65	160	750	1,550
Helium & hydrogen	90	200	940	1,930
Pumping speed AVS 4.1 (1963)*		285	1,200	2,400
Maximum forepressure, Torr (mbar)				
No load	0.75 (1.00)	0.55 (0.72)	0.65 (0.86)	0.65 (0.85)
Full load	0.60 (0.78)	0.40 (0.52)	0.55 (0.73)	0.55 (0.72)
Maximum throughput, T-l/s (mbar-l/s) In operating range @ 1 x 10 ⁻² Torr (1.3 x 10 ⁻² mbar)	0.19 (0.25) 0.30 (0.40)	0.60 (0.80) 0.70 (0.93)	1.5 (2.0) 2.5 (3.2)	2.4 (3.2) 3.5 (4.5)
Minimum recommended backing pump for maximum throughput, cfm (m ³ /hr)	0.15 (0.25)	5.0 (8.5)	10 (17)	17.0 (28.9)
Backstreaming rate at inlet flange mg/cm ² /min (standard cold cap)*	2 x 10 ⁻⁴	1 x 10 ⁻³	5 x 10 ⁻⁴	5 x 10 ⁻⁴
Warmup time, minutes	7	15	10	10
Cooldown time, minutes with quick cool coil, where applicable	10	10	10	10
Fluid charge	30 cc	100 cc	300 cc	500 cc
Electrical requirements	1 ph 50/60 Hz 90/115/165/220 V	1 ph 50/60 Hz 120/240 V	1 ph 50/60 Hz 120/208/240 V	1 ph 50/60 Hz 120/208/240 V
Power, watts	200/250	450	1,45	2,2
Cooling water, U.S. gpm (l/hr) at 60-80 °F (15-26 °C)	N/A	0.1 (20)	0.15 (30)	0.25 (50)

*For descriptions of pumping speed and backstreaming measurements, please see page 34.



DIFFUSION PUMPS

VHS-250	VHS-10	VHS-400	HS-16	HS-20	HS-32	NHS-35
0178	0185	0182	0164	0165	0167	0169
2,125 2,660 3,700	3,650 4,560 5,300	4,500 5,625 8,000	6,000 7,500 10,000	10,000 12,500 17,500	17,300 21,625 32,000	28,000 35,000 50,000
0.65 (0.85) 0.55 (0.72)	0.65 (0.85) 0.55 (0.72)	0.65 (0.85) 0.55 (0.72)	0.65 (0.85) 0.55 (0.72)	0.65 (0.85) 0.55 (0.72)	0.50 (0.65) 0.35 (0.45)	0.55 (0.71) 0.40 (0.52)
2.6 (3.5) 3.5 (4.5)	6.3 (8.4) 7.5 (10.0)	6.3 (8.4) 7.5 (10.0)	9.5 (11.7) at 8100 W 11.5 (15.3) at 8100 W	12.5 (16.7) 18 (23.4)	30 (40) 35 (45.5)	25 (33) 35 (45.5)
17.0 (28.9)	30 (51)	30 (51)	80 (136)	100 (170)	300 (510)	300 (510)
5×10^{-4}	5×10^{-4}	1×10^{-3}	1.5×10^{-3}	1.5×10^{-3}	7×10^{-4}	5×10^{-4}
10	15	15	30	45	60	60
10	25	25	30	45	60	60
500 cc	1,000 cc	1,000 cc	3 U.S. qts. (2.8 liters)	5 U.S. gal. (4.7 liters)	3 U.S. gal. (11.3 liters)	3 U.S. gal. (11.3 liters)
1 ph 50/60 Hz 120/208/240 V	3 ph 50/60 Hz 208/240/380/480 V	3 ph 50/60 Hz 208/240/380/480 V	3 ph 50/60 Hz 240/415/480 V	3 ph 50/60 Hz 240/415/480 V	3 ph 50/60 Hz 240/415/480 V	50/60 Hz 240/415/480 V
2,2	4,4	4,4	8,100/9,600	12	24	24
0.25 (50)	0.40 (80)	0.40 (80)	1.5 (300)	1.5 (300)	4.0 (800)	4.0 (800)

Diffusion Pumps



PUMP MODELS

▶ Agilent AX-65

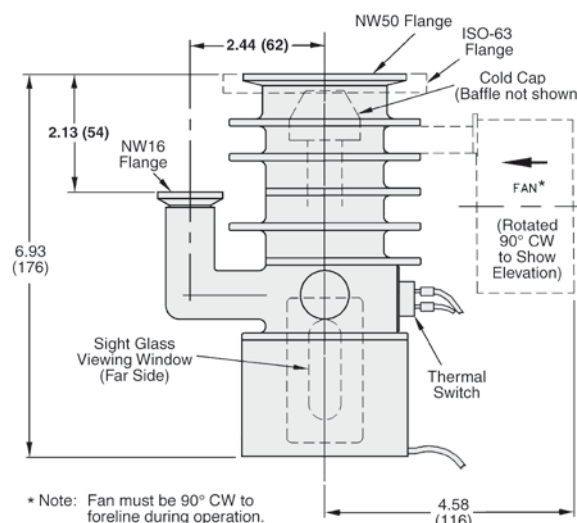

Dimensions: inches (millimeters)

Technical Specifications

Pumping speed*, operating range	65 l/sec air, 90 l/s He and H ₂
Maximum throughput	0.19T-l/s (0.25 mbar-l/s) in operating range, 0.30T-l/s (0.40 mbar-l/s) @ 0.01 Torr
Compression ratio	4 x 10 ⁷ (air), 2 x 10 ⁶ (helium)
Operating range	3 x 10 ⁻³ to <5 x 10 ⁻⁸ Torr (3.9 x 10 ⁻³ to 6.5 x 10 ⁻⁸ mbar)
Maximum forepressure	No load: 0.75 Torr (1.00 mbar) Full load: 0.60 Torr (0.78 mbar)
Backstreaming rate**	With cold cap: <2 x 10 ⁻⁴ mg/cm ² /min With baffle: <2 x 10 ⁻⁵ mg/cm ² /min
Recommended backing pump	≥1.5 cfm (2.5 m ³ /hr)
Warmup time	7 minutes
Cooldown time	10 minutes
Fluid charge	30 cc
Electrical requirements	1 ph, 50/60 Hz, 90/115/165/220 VAC
Pump power	200/250 watts
Air cooling	30 cfm

* For an explanation of pumping speed measurements, please see page 34.

** Refer to page 32 for a description of test methods.

DIFFUSION PUMPS

AX-65 - Pumping Speed - Air/N₂

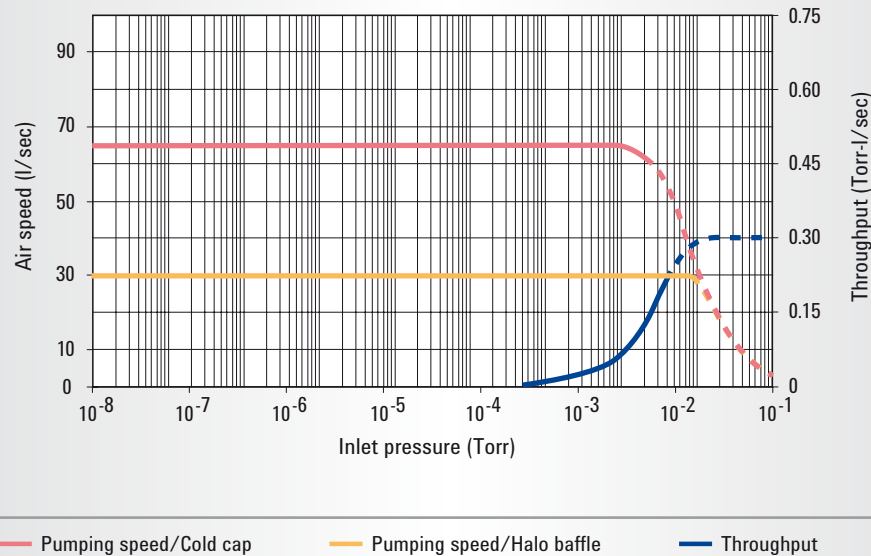

Ordering Information

Description	Wt. kg (lbs)	Part Number	
		KF-50	ISO-6
AX-65 with standard cold cap, 115 V, 250 W	3.6 (8.0)	L9670301	L9707301
AX-65 with internal baffle, 115 V, 250 W	3.6 (8.0)	L9670311	L9707311
AX-65 with standard cold cap, 220 V, 250 W	3.6 (8.0)	L9670302	L9707302
AX-65 with internal baffle, 220 V, 250 W	3.6 (8.0)	L9670312	L9707312
AX-65 with standard cold cap, 115 V, 200 W	3.6 (8.0)	L9670303	L9707303
AX-65 with internal baffle, 115 V, 200 W	3.6 (8.0)	L9670313	L9707313
AX-65 with standard cold cap, 220 V, 200 W	3.6 (8.0)	L9670304	L9707304
AX-65 with internal baffle, 220 V, 200 W	3.6 (8.0)	L9670314	L9707314
AX-65 with standard cold cap, 90 V, 250 W	3.6 (8.0)	L9670305	L9707305
AX-65 with internal baffle, 90 V, 250 W	3.6 (8.0)	L9670315	L9707315
AX-65 with standard cold cap, 165 V, 250 W	3.6 (8.0)	L9670306	L9707306
AX-65 with internal baffle, 165 V, 250 W	3.6 (8.0)	L9670316	L9707316

- NOTE**
- All pumps have NW-16 foreline
 - See page 30 for Santovac 5 diffusion pump fluid
 - Mounted cooling fan included with each pump (P/N 661300138)
 - Overtemperature thermal switch set to open at 365 °F (182 °C)
 - Use 250W heater with polyphenyl ether fluids (such as Santovac 5). Use 200 W heater for other fluids.

Description	Wt. kg (lbs)	Part Number
Accessories		
Santovac 5 diffusion pump fluid, 40 cc	0.5 (1.0)	695405001
Santovac 5 diffusion dump fluid, 65 cc	0.9 (2.0)	695405002
Internal baffle kit	0.9 (2.0)	R1160065
Centering ring for inlet flange, NW50	0.5 (1.0)	KC50SB
Centering ring for inlet flange, ISO-63	0.2 (0.5)	IC063SV
Centering ring for foreline flange, NW16	0.2 (0.5)	KC16SB
Installation and Operation Manual (download from www.agilent.com/chem/vacuum)		699901062
Replacement Parts (one heater harness required per pump)		
200 W, 115 V heater harness (for use with DC-704 and DC-702 or equivalents)	0.5 (1.0)	L9994307
250 W, 115 V heater harness (for use with DC-705/or equivalent and Santovac 5)	0.5 (1.0)	L9994303
200 W, 220 V heater harness (for use with DC-704 and DC-702 or equivalents)	0.5 (1.0)	L9994308
250 W, 220 V heater harness (for use with DC-705/or equivalent and Santovac 5)	0.5 (1.0)	L9994304
250 W, 90 V heater harness (for use with DC-705/or equivalent and Santovac 5)	0.5 (1.0)	L9994301
250 W, 165 V heater harness (for use with DC-705/or equivalent and Santovac 5)	0.5 (1.0)	L9994302
Overtemperature thermal switch (included with each heater harness)	0.5 (1.0)	L9964001
Pump ready thermal switch (optional)	0.5 (1.0)	L9964002

PUMP MODELS

▶ Agilent HS-2

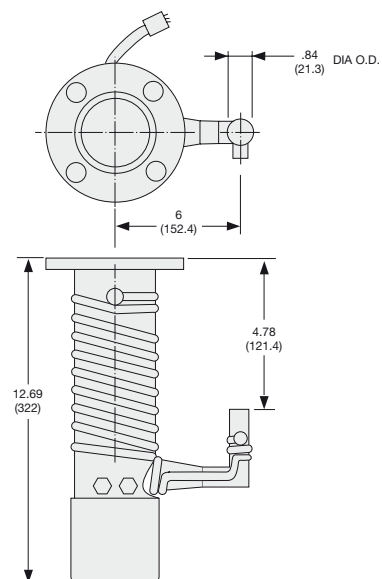

Dimensions: inches (millimeters)

Technical Specifications

Pumping speed, operating range	160 l/s air, 200 l/s He and H ₂
Pumping speed*, AVS 4.1 (1963)	285 l/s air
Maximum throughput	0.60 T-l/s (0.80 mbar-l/s) in operating range, 0.70 T-l/s (0.93 mbar-l/s) @ 0.01 Torr
Operating range	3.7×10^{-3} to $< 5 \times 10^{-8}$ Torr, (4.9×10^{-3} to $< 6.5 \times 10^{-8}$ mbar)
Maximum forepressure	No load: 0.55 Torr (0.71 mbar) Full load: 0.40 Torr (0.52 mbar)
Recommended backing pump	≥ 5 cfm (8.5 m ³ /hr)
Backstreaming rate**, standard cold cap	$< 1 \times 10^{-3}$ mg/cm ² /min
Warmup time	15 minutes
Cooldown time	10 minutes (with quick cool coil)
Fluid charge	100 cc
Electrical requirements	1 ph, 50/60 Hz, 120/240 VAC
Pump power	450 watts
Cooling water requirements	0.1 gpm (20 l/hr) at 60-80 °F (15-26 °C)
Water connections	1/8 in. FPT

* For an explanation of pumping speed measurements, please see page 34.

** Refer to page 32 for a description of test methods.

DIFFUSION PUMPS

HS-2 Pumping Speed - Air/N₂

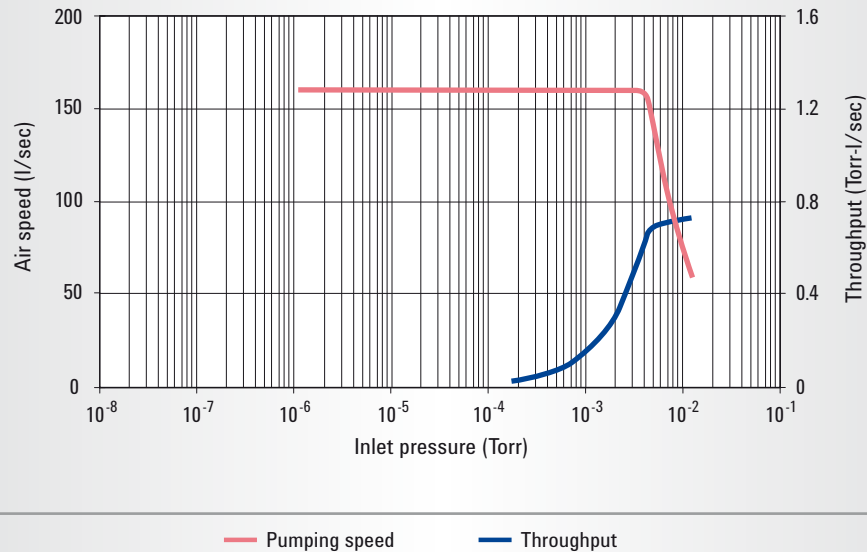

Ordering Information

Description	Wt. kg (lbs)	Part Number
ASA		
With standard cold cap, 120 V	20.0 (9.0)	82906301
With standard cold cap, 240 V	20.0 (9.0)	82906302
Description	Wt. kg (lbs)	Part Number
Water-cooled baffle with ASA flanges	10.0 (4.5)	F9453302
Santovac 5 diffusion pump fluid, 500 cc _ pump fluid, 500 cc	2.5 (1.1)	695405005
Installation and Operation Manual (download from www.agilent.com/chem/vacuum)		699901150

Description	Wt. kg (lbs)	Part Number
Replacement Parts (one heater required per pump)		
350 W, 120 V heater (HS2A)	1.0 (0.5)	647301100
350 W, 240 V heater (HS2A)	1.0 (0.5)	647301125
450 W, 120 V heater	1.0 (0.5)	647302125
450 W, 240 V heater	1.0 (0.5)	647302150
Heater block (one required per pump)	1.0 (0.5)	82920001
Heater platen (one required per pump)	1.0 (0.5)	82918301
Replacement o-ring kit, (5 Inlet flange o-rings (butyl 2-338))	1.0 (0.5)	K0377159

- NOTE**
- Inlet flange: nominal 2 in. ASA flange with 6 in. OD
 - Foreline flange: 0.84 in. diameter tube
 - See page 31 for baffles
 - See page 30 for santovac 5 diffusion pump fluid

PUMP MODELS

▶ Agilent VHS-4

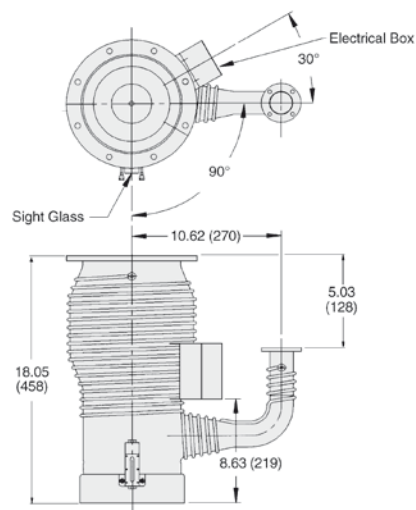

Dimensions: inches (millimeters)

Technical Specifications

Pumping speed*, operating range	750 l/s air, 940 l/s He/H ₂
Pumping speed*, AVS 4.1 (1963)	1,200 l/s air
Maximum throughput	1.5 T-l/s (2.0 mbar-l/s) in operating range, 2.5 T-l/s (3.2 mbar-l/s) @ 0.01 Torr
Operating range	2×10^{-3} to $<5 \times 10^{-9}$ Torr (2.7×10^{-3} to $<6.5 \times 10^{-9}$ mbar)
Maximum forepressure	No load: 0.65 Torr (0.86 mbar) Full load: 0.55 Torr (0.73 mbar)
Recommended backing pump	≥ 10 cfm (17 m ³ /hr)
Backstreaming rate**, standard cold cap	$<5 \times 10^{-4}$ mg/cm ² /min
Warmup time	10 minutes
Cooldown time	10 minutes (with quick cool coil)
Fluid charge	300 cc
Electrical requirements	1 ph, 50/60 Hz, 120/208/240 VAC
Pump power	1450 watts
Cooling water requirements	0.15 gpm (30 l/hr) at 60-80 °F (15-26 °C)
Water connections	1/8 in. FPT Tee

* For an explanation of pumping speed measurements, please see page 34.

** Refer to page 32 for a description of test methods.

DIFFUSION PUMPS

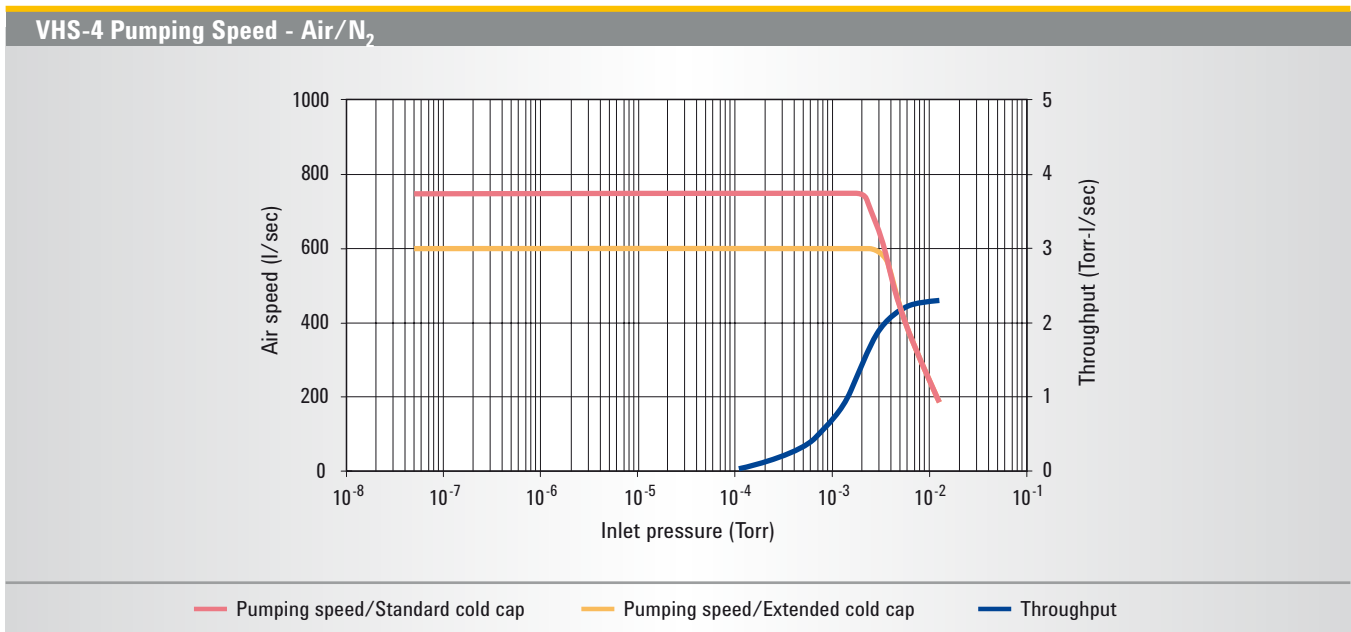

Ordering Information

Description	Voltage	Weight kg (lbs)	Part Number	
			Flange Type	ISO
VHS-4 Pump			ASA	ISO
VHS-4 with standard cold cap	120 V	25.0 (55.0)	86460301	L6256301
VHS-4 with extended cold cap	120 V	25.0 (55.0)	86460311	L6256311
VHS-4 with standard cold cap	208 V	25.0 (55.0)	86460306	L6256306
VHS-4 with extended cold cap	208 V	25.0 (55.0)	86460316	L6256316
VHS-4 with standard cold cap	240 V	25.0 (55.0)	86460302	L6256302
VHS-4 with extended cold cap	240 V	25.0 (55.0)	86460312	L6256312
Accessories				
	Page	Weight kg (lbs)	Part Number	
Water-cooled baffle with ASA flanges	31	4.5 (10.0)	F8286304	
Water-cooled baffle with ISO flanges	31	4.5 (10.0)	F8286305	
Centering ring for ISO inlet flange, 160K		0.5 (1.0)	IC160SV	
Centering ring for ISO foreline flange, KF40		0.2 (0.5)	KC40SV	
Santovac 5 diffusion pump fluid, 500 cc	30	1.1 (2.5)	695405005	
Installation and Operation Manual (download from www.agilent.com/chem/vacuum)			699901021	
Replacement Parts (one heater required per pump)				
1450 W, 120 V heater		0.5 (1.0)	647304205	
1450 W, 208 V heater		0.5 (1.0)	647304210	
1450 W, 240 V heater		0.5 (1.0)	647304250	
Heater clamp (one required per pump)		1.0 (2.0)	88164301	
VHS-4 heater wire, 10 AWG, 24 inches (3 per pump required)		0.5 (0.2)	X3901-68001	
Replacement o-ring kit (kit contains: 3 inlet flange o-rings (butyl 2-258), 10 fill and drain o-rings (Viton 2-113), sight glass o-ring and gasket)		0.5 (1.0)	K0377183	
Thermal switch (set at 300 °F – 147 °C)		0.5 (1.0)	642906025	
Extended cold cap	31	0.5 (1.0)	F6898301	
Sight glass repair kit			L8908301	

NOTE

- Inlet flange 4 in. ASA , foreline flange KF40
- Inlet flange ISO 160K, foreline flange ISO KF40
- Pumps with ISO flanges do not include required centering rings

PUMP MODELS

▶ Agilent VHS-6

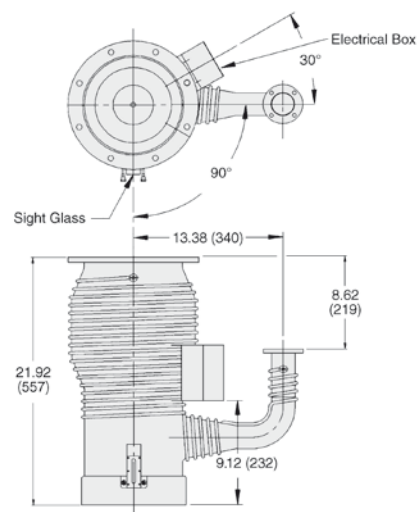

Dimensions: inches (millimeters)

Technical Specifications

Pumping speed, operating range	1,550 l/s air, 1,930 l/s He/H ₂
Pumping speed*, AVS 4.1 (1963)	2,400 l/s air
Maximum throughput	2.4 T-l/s (3.2 mbar-l/s) in operating range, 3.5 T-l/s (4.5 mbar-l/s) @ 0.01 Torr
Operating range	1.5×10^{-3} to $<5 \times 10^{-9}$ Torr (2×10^{-3} to $< 6.5 \times 10^{-9}$ mbar)
Maximum forepressure	No load: 0.65 Torr (0.85 mbar) Full load: 0.55 Torr (0.72 mbar)
Recommended backing pump	≥ 17 cfm (29 m ³ /hr)
Backstreaming rate**, standard cold cap	$<5 \times 10^{-4}$ mg/cm ² /min
Warmup time	10 minutes
Cooldown time	10 minutes (with quick cool coil)
Fluid charge	500 cc – exact fluid charge available
Electrical requirements	1 ph, 50/60 Hz, 120/208/240 VAC
Pump power	2200 watts
Cooling water requirements	0.25 gpm (50 l/hr) at 60-80 °F (15-26 °C)
Water connections	1/8 in. FPT Tee

* For an explanation of pumping speed measurements, please see page 34.

** Refer to page 32 for a description of test methods.

DIFFUSION PUMPS

VHS-6 Pumping Speed - Air/N₂

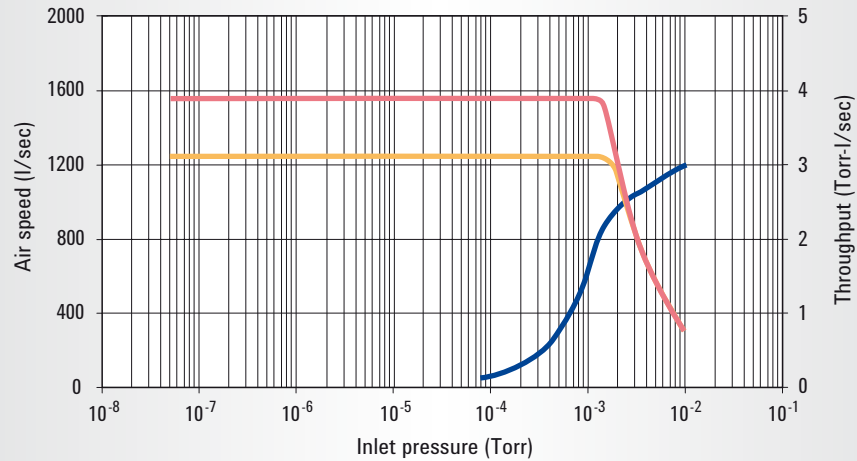

— Pumping speed/Standard cold cap — Pumping speed/Extended cold cap — Throughput

Ordering Information

Description	Voltage	Weight kg (lbs)	Part Number	
			Flange Type ASA	ISO
VHS-6 Pump				
VHS-6 with standard cold cap	120 V	34.0 (75.0)	85826301	L6193301
VHS-6 with extended cold cap	120 V	34.0 (75.0)	85826311	L6193311
VHS-6 with standard cold cap	208 V	34.0 (75.0)	85826306	L6193306
VHS-6 with extended cold cap	208 V	34.0 (75.0)	85826316	L6193316
VHS-6 with standard cold cap	240 V	34.0 (75.0)	85826302	L6193302
VHS-6 with extended cold cap	240 V	34.0 (75.0)	85826312	L6193312
Accessories				
Water-cooled baffle with ASA flanges	31	7.0 (15.0)	F8277306	
Water-cooled baffle with ISO flanges	31	7.0 (15.0)	F8277307	
Santovac 5 diffusion pump fluid, 500 cc (exact pump charge)	30	1.1 (2.5)	695405005	
Centering ring for ISO inlet flange, 200K		0.5 (1.0)	IC200SV	
Centering ring for ISO foreline flange, KF50		0.2 (0.5)	KC50SV	
Installation and Operation Manual (download from www.agilent.com/chem/vacuum)			699901022	
Replacement Parts (one heater required per pump)				
2200 W, 120 V heater		0.5 (1.0)	647306125	
2200 W, 208 V heater		0.5 (1.0)	647306175	
2200 W, 240 V heater		0.5 (1.0)	647306225	
Heater clamping assembly (includes clamping plate, cover plate, insulator)			86643301	
Heater cover plate (one required per pump)		1.0 (2.0)	86088001	
Heater insulator (one required per pump)		0.2 (0.5)	86087001	
Heater clamping plate (one required per pump)		0.5 (1.0)	86086301	
VHS-6/250 heater wire, 10 AWG, 36 inches (3 per pump required)		0.5 (2.0)	X3901-68002	
Replacement o-ring kit (kit contains: 3 inlet flange o-rings (butyl 2-267), 3 foreline flange o-rings (butyl 2-332), sight glass o-ring and gasket, 10 fill and drain o-rings (Viton 2-113))		0.5 (1.0)	K0377184	
Thermal switch (set at 300 °F – 147 °C)		0.5 (1.0)	642906025	
Extended cold cap	31	0.5 (1.0)	F6455001	

NOTE

- Inlet flange 6 in. ASA , foreline flange 1.5 in. ASA
- Inlet flange ISO 200K, foreline flange ISO KF50
- Pumps with ISO flanges do not include required centering rings

PUMP MODELS

▶ Agilent VHS-250

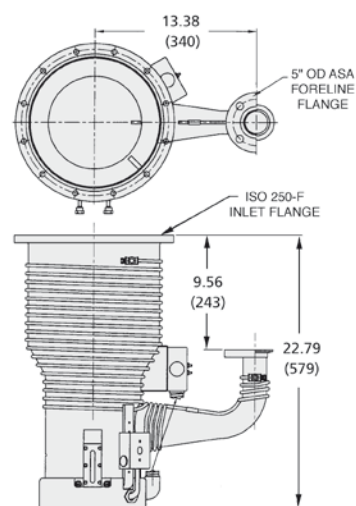

Dimensions: inches (millimeters)

Technical Specifications

Pumping speed, operating range	2,125 l/s air, 2,660 l/s He/H ₂
Pumping speed*, AVS 4.1 (1963)	3,700 l/s air
Maximum throughput	2.6 T-l/s (3.5 mbar-l/s) in operating range, 3.5 T-l/s (4.5 mbar l/s) @ 0.01 Torr
Operating range	1.2×10^{-3} to $<5 \times 10^{-9}$ Torr (1.6×10^{-3} to $<6.5 \times 10^{-9}$ mbar)
Maximum forepressure	No load: 0.65 Torr (0.85 mbar) Full load: 0.55 Torr (0.72 mbar)
Recommended backing pump	≥ 17 cfm (29 m ³ /hr)
Backstreaming rate**, standard cold cap	$< 5.0 \times 10^{-4}$ mg/cm ² /min
Warmup time	10 minutes
Cooldown time	10 minutes (with quick cool coil)
Fluid charge	500 cc – exact fluid charge available
Electrical requirements	1 ph, 50/60 Hz, 120/208/240 VAC
Pump power	2200 watts
Cooling water requirements	0.25 gpm (50 l/hr)
Water connections	1/8 in. FPT Tee

* For an explanation of pumping speed measurements, please see page 34.

** Refer to page 32 for a description of test methods.

DIFFUSION PUMPS

VHS-250 Pumping Speed - Air/N₂

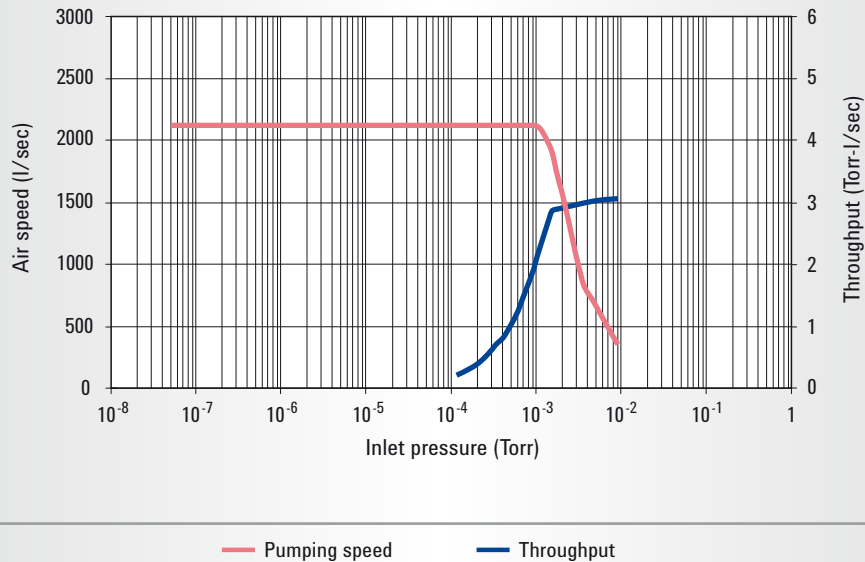

Ordering Information

Description	Voltage	Weight kg (lbs)	Part Number
VHS-250 pump			
VHS-250 with standard cold cap	120 V	34.0 (75.0)	K0543301
VHS-250 with standard cold cap	208 V	34.0 (75.0)	K0543306
VHS-250 with standard cold cap	240 V	34.0 (75.0)	K0543302

Accessories

Santovac 5 diffusion pump fluid, 500 cc (exact pump charge)		1.1 (2.5)	695405005
Installation and Operation Manual (download from www.agilent.com/chem/vacuum)			699901020

Replacement Parts (one heater required per pump)

2200 W, 120 V heater		0.5 (1.0)	647306125
2200 W, 208 V heater		0.5 (1.0)	647306175
2200 W, 240 V heater		0.5 (1.0)	647306225
Heater cover plate (one required per pump)		1.0 (2.0)	86088001
Heater insulator (one required per pump)		0.2 (0.5)	86087001
Heater clamping plate (one required per pump)		0.5 (1.0)	86086301
VHS-6/250 heater wire, 10 AWG, 36 inches (3 per pump required)		0.5 (2.0)	X3901-68002
Replacement o-ring kit (kit contains: 3 inlet flange o-rings (butyl 2-379), 3 foreline flange o-rings (butyl 2-332), sight glass o-ring and gasket, 10 fill and drain o-rings (Viton 2-113))		0.5 (1.0)	K0377178
Thermal switch (set at 300 °F – 147 °C)		0.5 (1.0)	642906025

NOTE • Inlet flange: ISO 250F (bolted, o-ring seal)
• Foreline flange: ASA with 5 in. OD

PUMP MODELS

▶ Agilent VHS-10

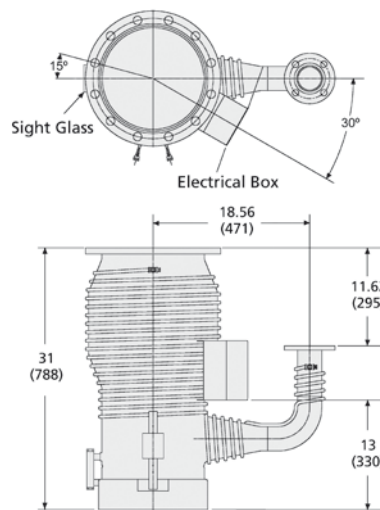

Dimensions: inches (millimeters)

Technical Specifications

Pumping speed, operating range	3,650 l/s air, 4,560 l/s He/H ₂
Pumping speed*, AVS 4.1 (1963)	5,300 l/s air
Maximum throughput	6.3 T-l/s (8.4 mbar l/s) in operating range, 7.5 T-l/s (10.0 mbar l/s) @ 0.01 Torr
Operating range	1.7 x 10 ⁻³ to <5 x 10 ⁻⁹ Torr at 4400 W (2.3 x 10 ⁻³ to <6.5 x 10 ⁻⁹ mbar)
Maximum forepressure	No load: 0.65 Torr (0.85 mbar) Full load: 0.55 Torr (0.72 mbar)
Recommended backing pump	≥ 30 cfm (51 m ³ /hr)
Backstreaming rate**, standard cold cap	<5.0 x 10 ⁻⁴ mg/cm ² /min
Warmup time	15 minutes
Cooldown time	25 minutes
Fluid charge	1,000 cc
Electrical requirements	3 ph, 50/60 Hz, 208/240/380/480 VAC
Pump power	4400 watts
Cooling water requirements	0.40 gpm (80 l/hr)
Water connections	1/8 in. FPT Tee

* For an explanation of pumping speed measurements, please see page 34.

** Refer to page 32 for a description of test methods.

DIFFUSION PUMPS

VHS-10 Pumping Speed - Air/N₂

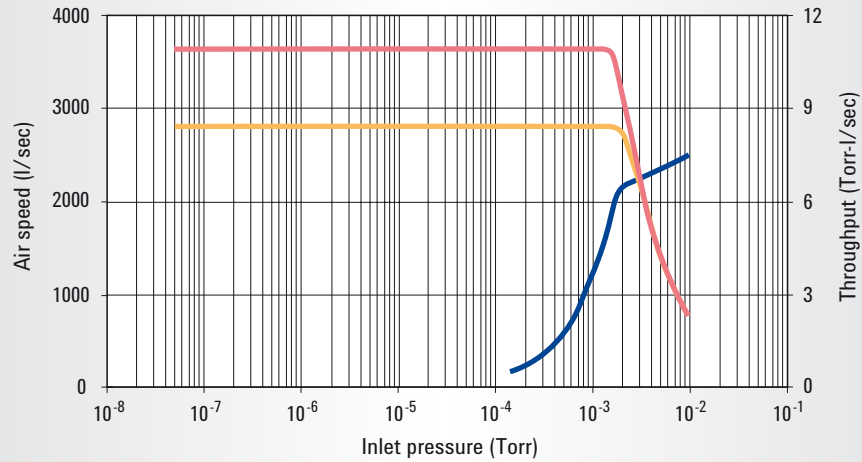

— Pumping speed/Standard cold cap — Pumping speed/Extended cold cap — Throughput

Ordering Information

Description	Wt. kg (lbs)	Part Number	
		ASA	ISO
VHS-10 with standard cold cap, 208 V	68 (150)	F0426307	L5920307
VHS-10 with extended cold cap, 208 V	68 (150)	F0426317	L5920317
VHS-10 with standard cold cap, 240 V	68 (150)	F0426308	L5920308
VHS-10 with extended cold cap, 240 V	68 (150)	F0426318	L5920318
VHS-10 with standard cold cap, 380 V	68 (150)	F0426326	L5920326
VHS-10 with extended cold cap, 380 V	68 (150)	F0426336	L5920336
VHS-10 with standard cold cap, 480 V	68 (150)	F0426309	L5920309
VHS-10 with extended cold cap, 480 V	68 (150)	F0426319	L5920319

Accessories	Wt. kg (lbs)	Part Number
Water-cooled baffle with ASA flanges	9.0 (20.0)	F8600310
Water-cooled baffle with ISO flanges	9.0 (20.0)	F8600311

NOTE

- Inlet flange 10 in. ASA, foreline flange 2 in. ASA
- Inlet flange ISO 320K, foreline ISO 63K
- See page 30 Santovac 5 diffusion pump fluid
- Baffles and extended cold caps can be found on page 31

Description	Wt. kg (lbs)	Part Number
Accessories (Cont'd)		
Centering ring for ISO foreline flange, 63K	0.5 (1.0)	IC063SV
Installation and Operation Manual (download from www.agilent.com/chem/vacuum)		699901023
Replacement Parts (two heaters required per pump)		
2200 W, 208 V heater	0.5 (1.0)	647310140
2200 W, 240 V heater	0.5 (1.0)	647310150
2200 W, 380 V heater	0.5 (1.0)	647310160
2200 W, 480 V heater	0.5 (1.0)	647310170
2550 W, 208 V heater	0.5 (1.0)	647310145
2550 W, 240 V heater	0.5 (1.0)	647310155
2550 W, 380 V heater	0.5 (1.0)	647310165
2550 W, 480 V heater	0.5 (1.0)	647310175
Heater crush plate (covers both heaters; one required for pump; replace when either heater is replaced)	1.0 (2.0)	K7667001
Heater clamping plate (one required per pump)	0.5 (1.0)	R2667301
VHS-10/400 heater wire, 10 AWG, 42 inches (3 per pump required)	1.0 (0.4)	X3901-68003
Replacement o-ring kit (kit contains: 1 inlet flange o-ring (butyl F0430001), 1 foreline flange o-ring (butyl 2-338), sight glass o-ring and gasket, 10 fill and drain o-rings (Viton 2-113))	1.0 (0.5)	K0377185
Thermal switch (set at 300 °F – 147 °C)	0.5 (1.0)	642906025
Extended cold cap	2.0 (0.9)	L8917301

PUMP MODELS

▶ Agilent VHS-400

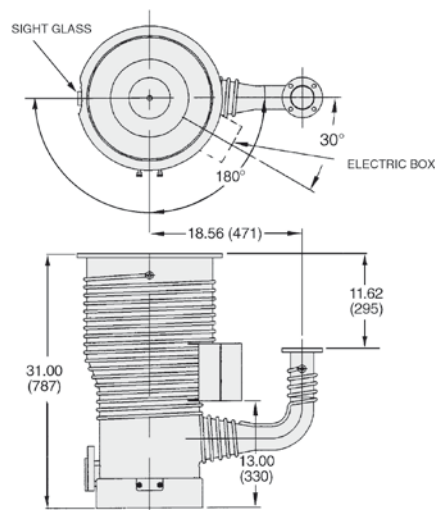

Dimensions: inches (millimeters)

Technical Specifications

Pumping speed, operating range	4,500 l/s air, 5,625 l/s He/H ₂
Pumping speed*, AVS 4.1 (1963)	8,000 l/s air
Maximum throughput	6.3 T-l/s (8.4 mbar l/s) in operating range, 7.5 T-l/s (10.0 mbar l/s) @ 0.01 Torr
Operating range	1.4 x 10 ⁻³ to <5 x 10 ⁻⁹ Torr (1.9 x 10 ⁻³ to <6.5 x 10 ⁻⁹ mbar)
Maximum forepressure	No load: 0.65 Torr (0.85 mbar) Full load: 0.55 Torr (0.72 mbar)
Recommended backing pump	≥30 cfm (51 m ³ /hr)
Backstreaming rate**, standard cold cap	<1.0 x 10 ⁻³ mg/cm ² /min
Warmup time	15 minutes
Cooldown time	25 minutes
Fluid charge	1,000 cc
Electrical requirements	3 ph, 50/60 Hz, 208/380/480 VAC
Pump power	4400 watts
Cooling water requirements	0.40 gpm (80 l/hr)
Water connections	1/8 in. FPT Tee

* For an explanation of pumping speed measurements, please see page 34.

** Refer to page 32 for a description of test methods.

DIFFUSION PUMPS

VHS-400 Pumping Speed - Air/N₂

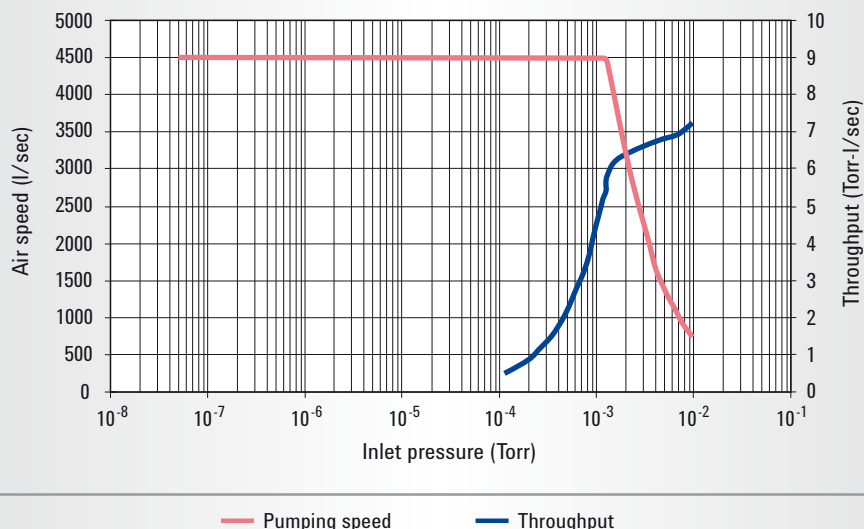

Ordering Information

Description	Voltage	Weight kg (lbs)	Part Number	
			Flange Type	
			ASA	ISO
VHS-400 Pump				
VHS-400 with standard cold cap	208 V	75.0 (180.0)	K4816307	L9767307
VHS-400 with standard cold cap	380 V	75.0 (180.0)	K4816326	L9767326
VHS-400 with standard cold cap	480 V	75.0 (180.0)	K4816309	L9767309
VHS-400 with standard cold cap	240 V	75.0 (180.0)	K4816308	L9767308
Accessories				
	Page	Weight kg (lbs)	Part Number	
Centering ring for ISO Inlet flange, 400K		0.5 (1.0)	IC400SV	
Centering ring for ISO foreline flange, 63K		0.5 (1.0)	IC063SV	
Installation and Operation Manual (download from www.agilent.com/chem/vacuum)			699901023	
Replacement Parts (two heaters required per pump)				
2200 W, 208 V heater		1.0 (0.5)	647310140	
2200 W, 240 V heater		1.0 (0.5)	647310150	
2200 W, 380 V heater		1.0 (0.5)	647310160	
2200 W, 480 V heater		1.0 (0.5)	647310170	
2550 W, 208 V heater		1.0 (0.5)	647310145	
2550 W, 240 V heater		1.0 (0.5)	647310155	
2550 W, 380 V heater		1.0 (0.5)	647310165	
2550 W, 480 V heater		1.0 (0.5)	647310175	
Heater crush plate (one required per pump; replace when either heater is replaced)		2.0 (1.0)	K7667001	
Heater clamping plate (one required per pump)		1.0 (0.5)	R2667301	
VHS-10/400 heater wire, 10 AWG, 42 inches (3 per pump required)		1.0 (0.4)	X3901-68003	
Replacement o-ring kit (kit contains: 1 inlet flange o-ring (butyl 2-385), foreline flange o-ring (butyl 2-338), sight glass o-ring and gasket, 10 fill and drain o-rings (Viton 2-113))		1.0 (0.5)	K0377189	
Thermal switch (set at 300 °F – 147 °C)		1.0 (0.5)	642906025	

NOTE

- Inlet flange ISO 400K, foreline flange ISO 63-K.
- Inlet flange non-standard ASA, foreline flange 2 in. ASA.
- Pumps with ASA flanges include O-Rings for inlet and foreline flanges
- Pumps with ISO flanges do not include centering rings required for inlet and foreline flanges.

PUMP MODELS

▶ Agilent HS-16

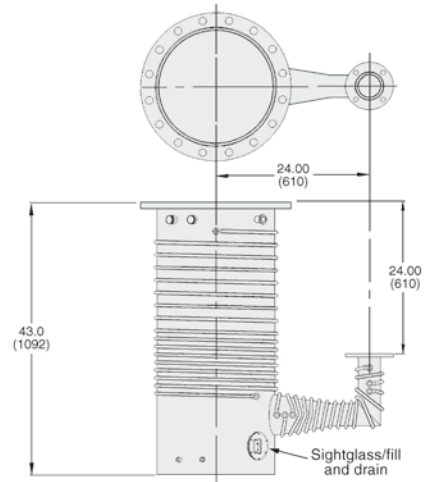

Dimensions: inches (millimeters)

HS-16 Pumping Speed - Air/N₂

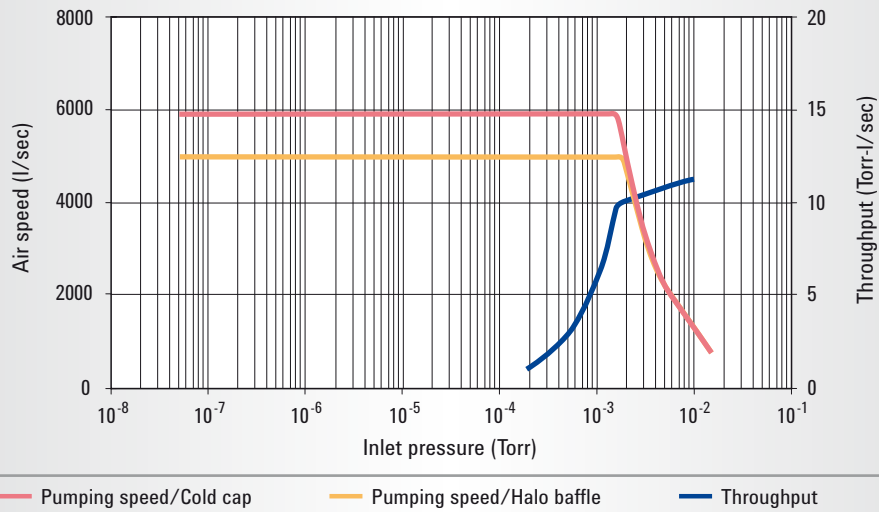

Technical Specifications

Pumping speed, operating range	6,000 l/s air, 7,500 l/s He and H ₂
Pumping speed*, AVS 4.1 (1963)	10,000 l/s air
Maximum throughput	8,100 W – 9.5 T-l/s (12.7 mbar l/s) in operating range 13.5 T-l/s (18.0 mbar-l/s) @ 0.01 Torr 9,600 W – 12.0 T-l/s (16 mbar l/s) in operating range 11.5 T-l/s (15.3 mbar-l/s) @ 0.01 Torr
Operating range	2 x 10 ⁻³ to <5 x 10 ⁻⁸ Torr at 9,600 W (1.3 x 10 ⁻³ to <6.5 x 10 ⁻⁸ mbar)
Maximum forepressure	No load – 0.65 Torr (0.85 mbar), Full Load – 0.55 Torr (0.72 mbar)
Pump power	8100/9600 watts
Recommended backing pump	≥ 80 cfm (136 m ³ /hr)
Backstreaming rate**, standard cold cap	<1.5 x 10 ⁻³ mg/cm ² /min
Warmup time	30 minutes
Cooldown time	48 minutes (30 minutes with optional quick cool coil)
Fluid charge	3 quarts (2.8 liters)
Electrical requirements	3 ph, 50/60 Hz, 240/415/480 VAC
Cooling water requirements	1.5 gpm (300 l/hr) at 60-80 °F (15-26 °C)
Water connections	¼ in. FPT Tee
Recommended fluid	DC-704 or equivalent (see page 30)

* For an explanation of pumping speed measurements, please see page 34.

** Refer to page 32 for a description of test methods.

DIFFUSION PUMPS

Ordering Information

Description	Voltage	Weight kg (lbs)	Part Number	
			Flange Type ASA	ISO
HS-16 Pump				
HS-16 with standard cold cap	240 V	218.0 (480.0)	79292308	L5921308
HS-16 with halo baffle	240 V	218.0 (480.0)	79292318	L5921318
HS-16 with standard cold cap	415 V	218.0 (480.0)	79292326	L5921326
HS-16 with halo baffle	415 V	218.0 (480.0)	79292336	L5921336
HS-16 with standard cold cap	480 V	218.0 (480.0)	79292309	L5921309
HS-16 with halo baffle	480 V	218.0 (480.0)	79292319	L5921319

NOTE • The HS-16 can be ordered with 9600 W heaters by increasing the middle number of the 3-digit suffix by two; eg 79292328

Accessories	Page	Weight kg (lbs)	Part Number
Water-cooled halo baffle	31	9.0 (20.0)	K0143316
Centering ring for ISO foreline flange, 100K		0.5 (1.0)	IC100SV
Quick cool coil – must be installed in the factory			Factory Special
Installation and Operation Manual (download from www.agilent.com/chem/vacuum)			699901140

Replacement Parts (three heaters required per pump)

2700 W, 240 V/415 V with leads		0.5 (1.0)	647316020
2700 W, 480 V with leads		0.5 (1.0)	647316030
2700 W, 240 V/415 V no leads – used on pumps built before May '90		0.5 (1.0)	647316035
2700 W, 480 V no leads – used on pumps built before May '90		0.5 (1.0)	647316045
3200 W, 240 V/415 V with leads		0.5 (1.0)	647316023
3200 W, 480 V with leads		0.5 (1.0)	647316033
Heater crush plate (replace one with each new heater)		0.5 (1.0)	K4919001
Heater insulator (three required per pump)		0.5 (1.0)	79309001
Heater clamping plate (three required per pump)		4.0 (8.0)	K4917001
HS-16/20/Dalton heater wire, 10 AWG, 120 inches (2 per heater required)		1.0 (0.4)	X3900-68000
Replacement o-ring kit for ASA pumps (kit contains: 1 inlet flange o-ring (buna 48214001), 1 foreline flange o-ring (buna 2-348), sight glass o-ring and gasket, 8 fill and drain o-rings (Viton 2-213))		0.5 (1.0)	K0377164
Sight glass service kit (pumps built before Oct. '95)		1.5 (3.0)	F6097301
Upper (water) thermal switch (set at 185 °F/85 °C)		0.5 (1.0)	K9050001
Lower (boiler) thermal switch (set at 390 °F/199 °C)		0.5 (1.0)	K9050002
Cold cap gasket/grommet (kit of 4)		0.5 (1.0)	L8839301
Cold cap nut and follower (2 each)		0.5 (1.0)	L8840301

NOTE • Inlet flange 16 in. ASA, foreline flange 3 in. ASA
 • Inlet flange ISO 500K, foreline flange ISO 100K
 • Not recommended for use with Santovac 5
 • Pumps with ASA flanges include o-rings for inlet and foreline flanges
 • Pumps with ISO flanges do not include centering rings required for foreline and inlet flanges

PUMP MODELS

▶ Agilent HS-20

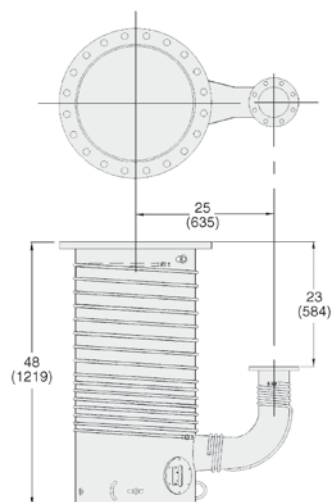

Dimensions: inches (millimeters)

HS-20 Pumping Speed - Air/N₂

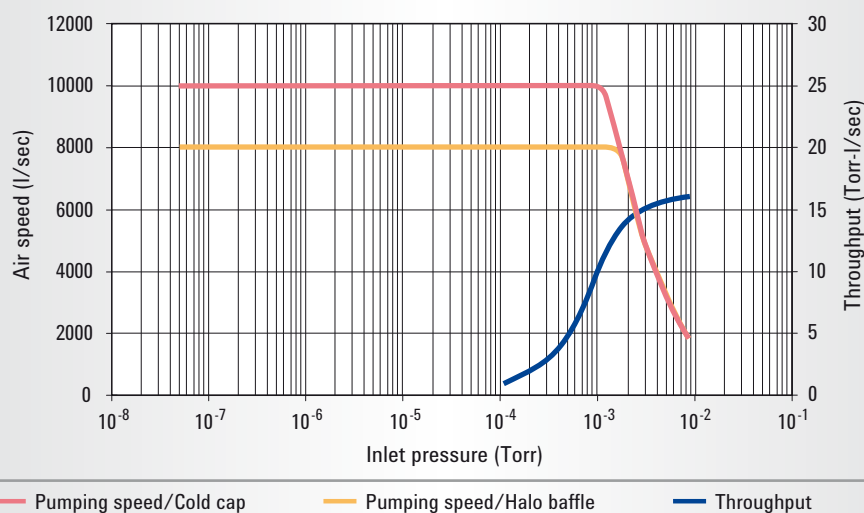

Technical Specifications

Pumping speed, operating range	10,000 l/s air, 12,500 l/s He and H ₂
Pumping speed*, AVS 4.1 (1963)	17,500 l/s air
Maximum throughput	12.5 T-l/s (16.7 mbar l/s) in operating range, 18 T-l/s (23 mbar-l/s) @ 0.01 Torr
Operating range	1.3 x 10 ⁻³ to 5 x 10 ⁻⁸ Torr (1.7 x 10 ⁻³ to 6.5 x 10 ⁻⁸ mbar)
Maximum forepressure	No load: 0.65 Torr (0.85 mbar) Full load: 0.55 Torr (0.72 mbar)
Recommended backing pump	≥100 cfm (170 m ³ /hr)
Backstreaming rate**, standard cold cap	<1.5 x 10 ⁻³ mg/cm ² /min
Warmup time	45 minutes
Cooldown time	85 minutes
Fluid charge	5 quarts (4.7 liters)
Electrical requirements	3 ph, 50/60 Hz, 240/415/480 VAC
Pump power	12,000 watts
Cooling water requirements	1.5 gpm (300 l/hr) at 60-80 °F (15-26 °C)
Water connections	¼ in. FPT Tee
Recommended fluid	DC-704 or equivalent (see page 30)

* For an explanation of pumping speed measurements, please see page 34.

** Refer to page 32 for a description of test methods.

DIFFUSION PUMPS

Ordering Information

Description	Voltage	Weight kg (lbs)	Part Number	
			ASA	ISO
HS-20 Pump				
HS-20 with standard cold cap	240 V	264.0 (580.0)	84341308	L5922308
HS-20 with halo baffle	240 V	264.0 (580.0)	84341318	L5922318
HS-20 with standard cold cap	415 V	264.0 (580.0)	84341326	L5922326
HS-20 with halo baffle	415 V	264.0 (580.0)	84341336	L5922336
HS-20 with standard cold cap	480 V	264.0 (580.0)	84341309	L5922309
HS-20 with halo baffle	480 V	264.0 (580.0)	84341319	L5922319
Accessories				
Water-cooled halo baffle	31	11.0 (25.0)	K1855320	
Centering ring for ISO foreline flange, 160K		0.5 (1.0)	IC160SV	
Quick cool coil – must be installed in the factory			Factory Special	
Installation and Operation Manual (download from www.agilent.com/chem/vacuum)			699901140	
Replacement Parts (six heaters required per pump)				
Heater, 2000 W, 240 V/415 V with leads		0.5 (1.0)	647320020	
Heater, 2000 W, 480 V with leads		0.5 (1.0)	647320030	
Heater, 2000 W, 240 V/415 V no leads – used on pumps built before May '90		0.5 (1.0)	647320060	
Heater, 2000 W, 480 V no leads – used on pumps built before May '90		0.5 (1.0)	647320070	
Heater crush plate (replace one with each new heater)		0.5 (1.0)	K7108001	
Heater clamping plate (six required per pump)		4.0 (8.0)	K7107001	
Heater insulator (one required per pump)		0.5 (1.0)	L6514001	
HS-16/20/Dalton heater wire, 10 AWG, 120 inches (2 per heater required)		1.0 (0.4)	X3900-68000	
Replacement o-ring kit for ASA pumps (kit contains 1 inlet flange o-ring (butyl 84349002), 1 foreline flange o-ring (buna 2-432), sight glass o-ring and gasket, 8 fill and drain o-rings (Viton 2-213))		0.5 (1.0)	K0377165	
Sight glass service kit (pumps built before Oct. '95)		1.5 (3.0)	F6097301	
Upper (water) thermal switch (set at 185 °F/85 °C)		0.5 (1.0)	K9050001	
Lower (boiler) thermal switch (set at 390 °F/199 °C)		0.5 (1.0)	K9050002	
Cold cap gasket/grommet (kit of 4)		0.5 (1.0)	L8839301	
Cold cap nut and follower (2 each)		0.5 (1.0)	L8840301	

- NOTE**
- Inlet flange 20 in. ASA, foreline flange 4 in. ASA
 - Inlet flange ISO 630K, foreline flange ISO 160K
 - Not recommended for use with Santovac 5
 - Pumps with ASA flanges include o-rings for inlet and foreline flanges
 - Pumps with ISO flanges do not include centering rings required for foreline and inlet flanges

PUMP MODELS

▶ Agilent HS-32

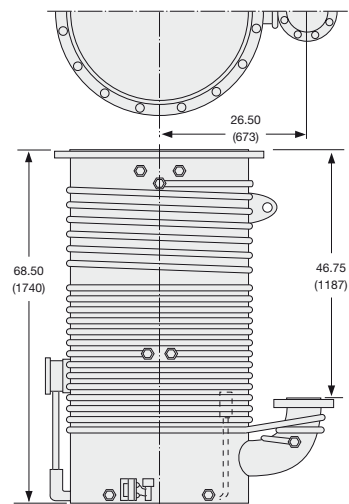

Dimensions: inches (millimeters)

Technical Specifications

Pumping speed, operating range	17,300 l/s air, 21,625 l/s He and H ₂
Pumping speed*, AVS 4.1 (1963)	32,000 l/s air
Maximum throughput	30 T-l/s (40 mbar l/s) in operating range, 35 T-l/s (45 mbar-l/s) @ 0.01 Torr
Operating range	1.7 x 10 ⁻³ to <5 x 10 ⁻⁸ Torr (2.3 x 10 ⁻³ to <6.5 x 10 ⁻⁸ mbar)
Maximum forepressure	No load: 0.50 Torr (0.65 mbar) Full load: 0.35 Torr (0.45 mbar)
Recommended backing pump	≥300 cfm (510 m ³ /hr)
Backstreaming rate**, standard cold cap	<7 x 10 ⁻⁴ mg/cm ² /min
Warmup time	60 minutes
Cooldown time	180 minutes
Fluid charge	3 U.S. gallons (11.3 liters)
Electrical requirements	3 ph, 50/60 Hz, 240/415/480 VAC
Pump power	24,000 watts
Cooling water requirements	4 gpm (800 l/hr) at 60-80 °F (15-26 °C)
Water connections	3/8 in. FPT Tee
Recommended fluid	DC-704 or equivalent (see page 30)

* For an explanation of pumping speed measurements, please see page 34.

** Refer to page 32 for a description of test methods.

DIFFUSION PUMPS

HS-32 Pumping Speed - Air/N₂

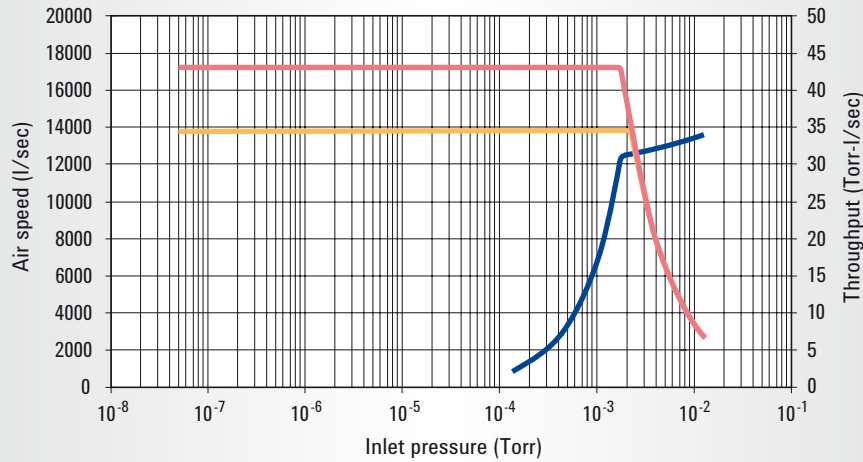

— Pumping speed/Cold cap — Pumping speed/Halo baffle — Throughput

Ordering Information

Description HS-32 Pump	Wt. kg (lbs)	Part Number	
		ASA	ISO
HS-32 with standard cold cap, 240 V	612 (1,350)	76134308	L5923308
HS-32 with halo baffle, 240 V	612 (1,350)	76134318	L5923318
HS-32 with standard cold cap, 415 V	612 (1,350)	76134326	L5923326
HS-32 with halo baffle, 415 V	612 (1,350)	76134336	L5923336
HS-32 with standard cold cap, 480 V	612 (1,350)	76134309	L5923309
HS-32 with halo baffle, 480 V	612 (1,350)	76134319	L5923319

Accessories	Wt. kg (lbs)	Part Number
Water-cooled halo baffle	16 (35)	K1856332
Quick cool coil – must be installed in the factory		Factory Special
Centering ring for ISO foreline flange, 200K	0.5 (1.0)	IC200SV
Installation and Operation Manual (download from www.agilent.com/chem/vacuum)		699901140

- NOTE**
- Inlet flange 32 in. ASA, foreline flange 6 in. ASA
 - Inlet flange ISO 800F (bolted), foreline flange ISO 200K (clamped)
 - Not recommended for use with Santovac 5
 - ASA pump versions include o-rings for both inlet and foreline flanges
 - ISO pump versions include inlet flange o-ring, but does not include foreline flange centering ring

Description	Wt. kg (lbs)	Part Number
Replacement Parts (six heaters required per pump)		
Heater*, 4000 W, 240 V/415 V/480 V with leads	0.5 (1.0)	647332010
Heater*, 4000 W, 240 V/415 V/480 V no leads – used on pumps built before May '90	0.5 (1.0)	647332075
<i>*One heater consists of 2-120V heaters, right and left</i>		
Heater crush plate (replace one with each new heater)	0.5 (1.0)	K7246001
Heater insulator (one required per pump)	0.5 (1.0)	75792001
Heater clamping plate (six required per pump)	4 (8)	K7247001
HS-32/35 heater wire, 10 AWG, 196 inches (2 per heater required)	1.0 (0.4)	X3900-68003
Replacement o-ring kit for ASA pumps (kit contains: 1 inlet flange o-ring (buna 45390001), 1 foreline flange o-ring (butyl 2-443), sight glass o-ring and gasket, 8 fill and drain o-rings (Viton 2-213))	0.5 (1.0)	K0377167
Sight glass service kit (pumps built before Oct. '95)	1.5 (3.0)	F6097301
Sight glass service kit (pumps built after Oct. '95)	1.5 (3.0)	L9223001
ISO inlet flange o-ring	0.5 (1.0)	78536002
Upper (water) thermal switch (set at 220 °F/104 °C)	0.5 (1.0)	K9050005
Lower (boiler) thermal switch (set at 550 °F/288 °C)	0.5 (1.0)	K9050004
Cold cap gasket/grommet (kit of 4)	0.5 (1.0)	L8839301
Cold cap nut and follower (2 each)	0.5 (1.0)	L8840301

Please note that this item is controlled for export by the Nuclear Suppliers Group. Accordingly, you may be required to obtain export licenses, including from US government authorities prior to exporting this diffusion pump from the United States. Please contact Agilent Vacuum Products, and the U.S. Export Administration regulations ECCN 2B231 for further guidance.

PUMP MODELS

▶ Agilent NHS-35

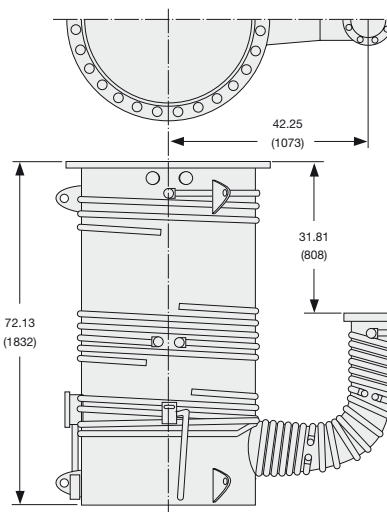

Dimensions: inches (millimeters)

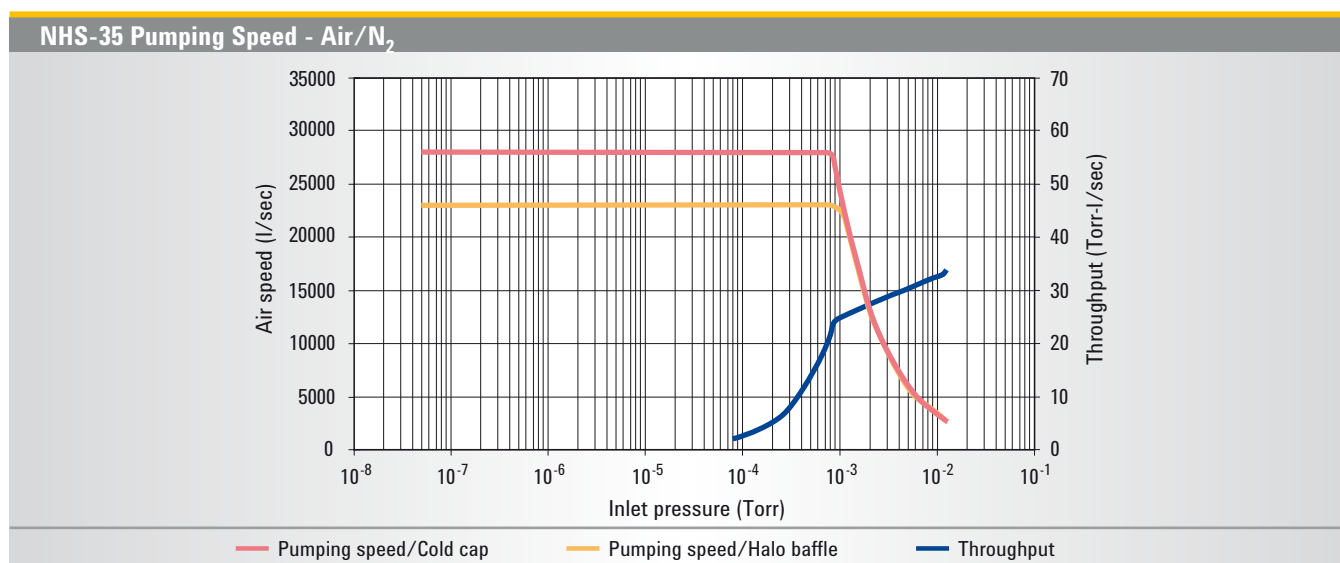

Technical Specifications

Pumping speed, operating range	28,000 l/s air, 35,000 l/s He and H ₂
Pumping speed*, AVS 4.1 (1963)	50,000 l/s air
Maximum throughput	25 T-l/s (33 mbar l/s) in operating range, 35 T-l/s (45 mbar-l/s) @ 0.01 Torr
Operating range	9 x 10 ⁻⁴ to < 5 x 10 ⁻⁸ Torr (1.2 x 10 ⁻³ < 6.5 x 10 ⁻⁸ mbar)
Maximum forepressure	No load – 0.55 Torr (0.71 mbar), Full Load – 0.40 Torr (0.52 mbar)
Recommended backing pump	≥300 cfm (510 m ³ /hr)
Backstreaming rate**, standard cold cap	<5 x 10 ⁻⁴ mg/cm ² /min
Warmup time	60 minutes
Cooldown time	180 minutes
Fluid charge	3 U.S. gallons (11.3 liters)
Electrical requirements	3 ph, 50/60 Hz, 240/415/480 VAC
Pump power	24,000 watts
Cooling water requirements	4 gpm (800 l/hr) at 60-80 °F (15-26 °C)
Recommended fluid	DC-704 or equivalent (see page 30)

* For an explanation of pumping speed measurements, please see page 34.

** Refer to page 32 for a description of test methods.

DIFFUSION PUMPS

Ordering Information

Description	Voltage	Weight kg (lbs)	Part Number	
			ASA	ISO
NHS-35 Pump				
NHS-35 with standard cold cap	240 V	680.0 (1,550.0)	F1730308	L5924308
NHS-35 with halo baffle	240 V	680.0 (1,550.0)	F1730318	L5924318
NHS-35 with standard cold cap	415 V	680.0 (1,550.0)	F1730326	L5924326
NHS-35 with halo baffle	415 V	680.0 (1,550.0)	F1730336	L5924336
NHS-35 with standard cold cap	480 V	680.0 (1,550.0)	F1730309	L5924309
NHS-35 with halo baffle	480 V	680.0 (1,550.0)	F1730319	L5924319

Accessories	Page	Weight kg (lbs)	Part Number
Water-cooled halo baffle	31	20.0 (45.0)	K1857335
Quick cool coil – must be installed in the factory, can not ship separately			Factory Special
Centering ring for ISO foreline flange, 200K		0.5 (1.0)	IC200SV
O-ring, ISO Inlet flange		0.5 (1.0)	78536002
Installation and Operation Manual (download from www.agilent.com/chem/vacuum)			699901140

Replacement Parts (six heaters required per pump)

Heater 4000 W, 240 V/480 V with leads		0.5 (1.0)	647335010
Heater 4000 W, 240 V/480 V no leads – used on pumps built before May '90		0.5 (1.0)	647235248
Heater, 4000 W, 200 V		0.5 (1.0)	647335020
Heater, 4000 W, 400 V		0.5 (1.0)	L6383010
Heater, 4000 W, 440 V		0.5 (1.0)	L6383011
Heat shield (reusable)		0.5 (1.0)	L6370001
Heater clamping plate (six required per pump)		4.0 (8.0)	F1749001
Heater insulator (one required per pump)		0.5 (1.0)	L9699001
HS-32/35 heater wire, 10 AWG, 196 inches (2 per heater required)		1.0 (0.4)	X3900-68003
Replacement o-ring kit for ASA pumps (kit contains: 1 inlet flange o-ring (buna 78536001), 1 foreline flange o-ring (butyl 2-267), sight glass o-ring and gasket, 8 fill and drain o-rings (Viton 2-213))		0.5 (1.0)	K0377169
Sightglass service kit (pumps built before Oct. '95)		1.5 (3.0)	F6097301
Upper (water) thermal switch (set at 200 °F/93 °C)		0.5 (1.0)	K9050005
Lower (boiler) thermal switch (set at 600 °F/316 °C)		0.5 (1.0)	K9050006
Cold cap gasket/grommet (kit of 4)		0.5 (1.0)	L8839301
Cold cap nut and follower (2 each)		0.5 (1.0)	L8840301

- NOTE**
- Inlet flange 35 in. ASA, foreline flange 6 in. ASA
 - Inlet flange ISO 1000F (bolted), foreline flange ISO 200K (clamped)
 - Not recommended for use with Santovac 5
 - ASA pump versions include o-rings for both inlet and foreline flanges
 - ISO pump versions include inlet flange o-ring, but does not include foreline flange centering ring

Please note that this item is controlled for export by the Nuclear Suppliers Group. Accordingly, you may be required to obtain export licenses, including from US government authorities prior to exporting this diffusion pump from the United States. Please contact Agilent Vacuum Products, and the U.S. Export Administration regulations ECCN 2B231 for further guidance.

FLUIDS

Agilent offers NeoVac SY and Santovac 5 diffusion pump fluids in a variety of container sizes for your convenience.

	NEOVAC SY	DC-704*	SANTOVAC 5**
Chemical description	Synthetic hydrocarbon	Single-component silicone	Mixed 5-ring polyphenyl ether
Chemical composition	Mono-N alkylidiphenylether	Tetramethyltetraphenyltrisiloxane cyclosiloxane	Mixed 5-ring polyphenyl Ether
Ultimate pressure Untrapped (Torr)	Low 10^{-8} range	10^{-7} to 10^{-8} range	10^{-10}
Trapped (Torr)	1×10^{-11} range	to 10^{-11} range	–
Vapor pressure at 25 °C (Torr)	1×10^{-8}	2×10^{-8}	1×10^{-9} at 20 °C
Viscosity (cst) at 25 °C	25 at 40 °C	39	2400
Average molecular weight	405	484	446
Boiling temperature (°C) at 0.5 Torr	220 at 0.8 Torr	215	275
Flash point	230	221	288
Ultimate pressure	Very good	Very good	Excellent
Thermal stability	Good	Excellent	Very good
Oxidation resistance	Good	Excellent	Very good
System cleanliness	Very good	Very good	Excellent

* DC-704 specification values are included here for reference only. Not available for sale.

** Santovac 5 is the only recommended fluid for leak detectors.

NEOVAC SY is a high quality, low cost synthetic organic compound (alkylidiphenylether) that performs as well as DC-704. With its low vapor pressure, it will achieve base pressures in the low 10^{-8} Torr range untrapped and will not produce inorganic deposits which can cause electrostatic charge buildup on electrodes of sensitive instruments.

Santovac 5 is a five-ring polyphenylether for use in ultrahigh vacuum applications. With ultra low vapor pressure and backstreaming rates, this fluid is very clean and often eliminates the need for traps and baffles. Ultimate pressures in the 10^{-10} Torr range can be achieved and will not produce inorganic deposits which can cause electrostatic charge buildup on electrodes of sensitive instruments.

Ordering Information

Description	Diffusion Pump Exact Charge	Weight kg (lbs)	Part Number
NEOVAC SY			
1 liter/1,000 cc	VHS-10, VHS-400	3.0 (1.4)	K6948301
U.S. gallon (3.8 liters)		10.6 (4.8)	K6948305
5 U.S. gallons (18.9 liters)		53.0 (23.9)	K6948315
Santovac 5			
40 cc		1.0 (0.5)	695405001
65 cc		2.0 (0.9)	695405002
500 cc	VHS-6, VHS-250	2.5 (1.1)	695405005

BAFFLES

▶ Extended Cold Caps for VHS-4, -6, and -10 Diffusion Pumps

The Extended Cold Cap is an option that fits inside the VHS-4, VHS-6, and VHS-10 pumps in place of the standard cold cap. It stops backstreaming as effectively as an optically dense baffle, yet it retains 80% of the pump's speed. Residual backstreaming is so low that it cannot be measured by the American Vacuum Society's standard collection method.

Technical Specifications

Speed with Extended Cold Cap	≈ 80% of pump speed
Materials	Nickel-plated copper
Cooling	Conduction (no water)

DIFFUSION PUMPS



Ordering Information

Description	Weight kg (lbs)	Part Number
VHS-4	0.5 (1.0)	F6898301
VHS-6	0.5 (1.0)	F6455001
VHS-10	0.9 (2.0)	L8917301

▶ Halo Baffles for Large Diffusion Pumps for HS-16, -20, -32 and NHS-35 Diffusion Pumps

Agilent's Halo Baffles provide nearly twice the speed at the pump inlet as that achieved with conventional chevron baffles, while adding no height to the system. These water-cooled baffles are very economical compared to other opaque chevron baffles.

Technical Specifications

Net speed with Halo Baffle	Approximately 60% of pump speed*
Backstreaming reduction	Approximately 90%*
Materials	Nickel-plated copper (16 in., 20 in.) Nickel-plated mild steel (32 in., 35 in.)
Cooling: recommended Water flow	In series with diffusion pumps; see specific diffusion pump technical specs HS16 – NHS-35



Ordering Information

Baffle Size	Weight kg (lbs)	Part Number
16 in.	9.0 (20.0)	K0143316
20 in.	11.0 (25.0)	K1855320
32 in.	16.0 (35.0)	K1856332
35 in.	20.0 (45.0)	K1857335

* Values are estimates. Actual speed and backstreaming rate will vary depending on the application conditions.

TECHNICAL NOTES

Diffusion pumps were first conceived and constructed by W. Gaede (1915-Germany) and I. Langmuir (1916-U.S.A). They operate on the principle of transferring momentum from high velocity vapor molecules to the gas molecules that are to be moved out of the system. The vapor molecules are formed by heating a suitable condensable fluid. The early pumps used mercury for this purpose.

In the late 1920s, C.R. Burch (England) and K.C. Hickman (U.S.A.) found that certain high molecular weight oils having high boiling points and low vapor pressures could be used as pumping fluids. These oils were useful because they remained in the pump indefinitely and allowed lower pressures to be attained without the use of a cold trap (see section on Baffles and Traps). Today, with the exception of a few isolated applications like some analytical instruments, all diffusion pumps use some form of oil. For additional information in this area, see the discussion on pumping fluids below.

As industrial and scientific requirements for rarefied atmospheres increased, research and development into the nature and production of high vacuum increased. By the early 1940s, a well-developed vacuum technology existed and was intensified both during World War II and by the space effort of the 1960s. Engineering has continued in the vacuum field, and in 1965 Agilent's M.H. Hablanian, et al. made a significant contribution to diffusion pump design that markedly increased pumping speeds.

Applications

Due to its simplicity, high performance, and low initial cost, the diffusion pump remains a primary industrial high vacuum pumping mechanism. Applications for this type of pump are found in such diverse areas as:

1. Analytical instruments
2. Coating, functional
3. Coating, ornamental
4. Electron tube manufacture
5. Metallurgy
6. Optics
7. Outer space simulation
8. Particle accelerators
9. Petrochemicals
10. Pharmaceuticals
11. R&D laboratories
12. Semiconductor manufacture

Used in combination with the proper choice of motive fluids, traps, baffles, and valves, diffusion pumps can be used in a wide variety of applications and over pressure ranges from 1×10^{-3} Torr to 2×10^{-11} Torr.

Basic Performance Factors

1. Pumping speed is volume per unit time. It is generally specified in liters/second and is an important parameter in determining the ultimate pressure of a system.

This is expressed by the relationship

$$Q = PS$$

Where:

Q is the system gas load in Torr-liters/second

P is the attainable pressure in Torr

S is the effective pump speed at the system

"Q" is the total leakage of the system which includes vapors given off by dirt and outgassing of internal surfaces as well as holes to the outside world. Ultimate pressure is also affected by such factors as the compression ratio for light gases and the nature of the pumping fluid.

2. **Maximum throughput** is the pump's maximum gas mass transfer capability – pressure x volume per unit time. It is generally specified in Torr-liters/second or mbar l/s.
3. **Tolerable forepressure** is the maximum allowable pressure in the foreline. It is maintained at or below this value by a suitably-sized mechanical foreline (backing) pump. If this pressure increases above that specified for a given pump, gas will diffuse back through the pump and pumping will stop. It should be noted that the size of this mechanical pump can affect the maximum throughput value.
4. **Backstreaming rate** is the rate at which the pumping fluid vapor leaves the inlet opening of the pump, moving back in the direction of the system being pumped. It is measured in milligrams per cm^2 per unit time and will vary with the type of motive fluid employed.

Operation

Diffusion pumps are vapor jet pumps that work on the basis of momentum transfer from a heavy high speed vapor molecule to a gas molecule. This results in the gas molecules being moved through the pump.

In Figure 1, the bottom of the pump contains an electric heater that is used to produce the vapor by heating the pumping (motive) fluid to its boiling point at reduced pressure.

Figure 1 Typical Cross-sectional View of a Diffusion Pump

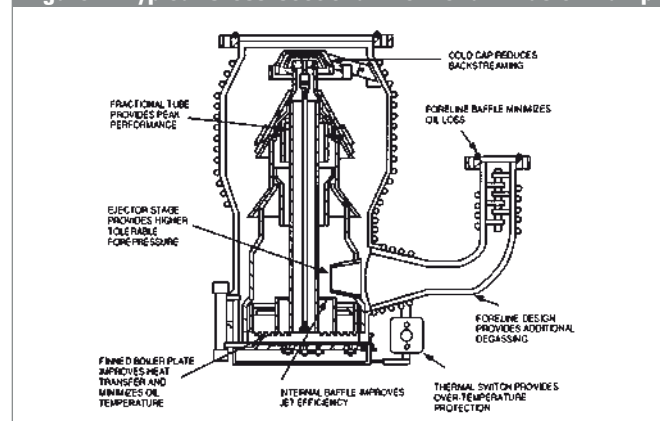

DIFFUSION PUMPS

This means that before the pump is started, it must be “rough pumped” down to and held at an acceptable pressure, typically 10⁻¹ Torr. (For information on rough pumping, see section on Primary Pumps.) To do otherwise will result in no pumping action and possible damage to the pumping fluids. Once boiling of the fluid has begun, the vapor is forced up the central columns of the jet assembly. It then exits at each downward-directed jet in the form of a molecular curtain that impacts the water-cooled pump body. Here, the vapor condenses and runs back down to the boiler. This refluxing action continues as long as proper heat and forepressure are maintained.

As gas molecules from the system randomly enter the pump (molecular flow conditions), they encounter the top jet. Some of them are correctly impacted and driven on to the next jet. Subsequently, they reach the foreline where they are exhausted to the atmosphere by the mechanical backing pump.

The diffusion pump is similar in character to other compression pumps in that it develops a relatively high exhaust pressure compared to the inlet pressure. This compression ratio for an inlet pressure of 2×10^{-7} Torr and a foreline pressure of 2×10^{-1} would be ten million to one for most gases. Figure 2 shows how the pumping speed varies with pressure. Note that the speed remains constant from the 10⁻³ Torr scale to the X⁻¹⁰ Torr scale and then falls off as a result of the compression ratio for hydrogen and helium plus the vapor pressure contribution of the pumping fluid.

In the same way that the pump must be rough pumped before starting, so must the system to be evacuated by rough pumping prior to exposure to the pump. Exposing a hot pump to a rush of air at atmospheric pressure could be catastrophic for the equipment and possibly explosive, depending upon the

pump fluid being used. For further information in this area, see the discussion on pumping fluids, below.

Design Features

Design features unique to Agilent diffusion pumps provide positive benefits to the customer, such as:

1. Agilent oil diffusion pumps incorporate an ejector stage as well as the full fractionation jets. This feature assures the user of constantly purified pumping fluid and the capability of maintaining low pressures.
2. Agilent oil diffusion pumps incorporate insulated jet drip shields which prevent re-boiling of oil droplets outside the jet assembly. This feature assures the user of the lowest backstreaming rates attainable.
3. Agilent water cooling coils are attached by a proprietary weld/brace technique. This special technique means excellent thermal contact and no chance for coils to “melt” away from the pump body in cases of accidental overheating.
4. Agilent pumps incorporate a water-cooled cold cap that reduces 98 percent of the backstreaming common to most diffusion pumps and the user is assured of a cleaner system.
5. Agilent water-cooled pumps incorporate the quick cool boiler coils, allowing faster shutdown of the system with no damage to the oil.
6. Agilent pumps use standard ASA flanges. This feature permits wide flexibility formatting with systems and other hardware.
7. Agilent (4-inch and larger) pumps have a thermal protection switch as a standard feature. This device prevents damage to the pump and surroundings due to overheating.

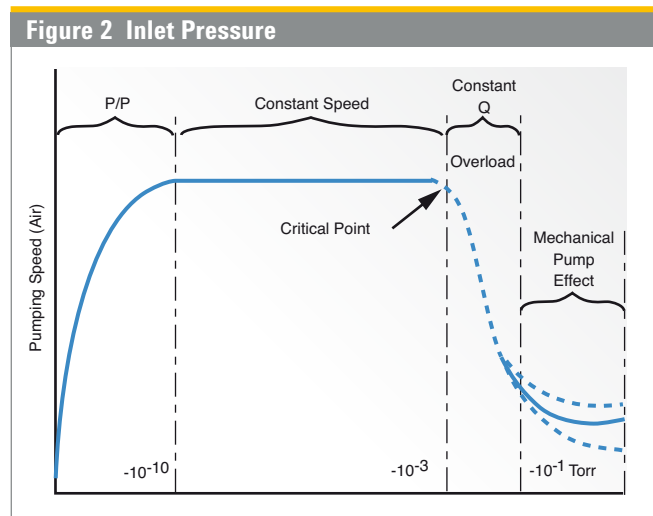

Typical plot of diffusion pump performance. Four regions are evident: 1) Effect of the pressure ratio limit; 2) Normal operating range with constant speed; 3) Throughput limited condition; 4) Effect of backing pump.

Pumping Fluids

In an oil diffusion pump, high speed heated oil vapor provides the kinetic energy that moves gas molecules to the foreline and prevents their back-migration. These oils may be derived from a petroleum base but more typically are synthesized from phthalates, sebacates, phenyl groups, or siloxanes.

To be an effective pumping fluid, the compound must have a relatively high molecular weight and a low vapor pressure at elevated temperatures. Other desirable properties are inertness and stability in order to resist chemical reaction and disintegration into undesirable fractions.

Phenyl ethers such as Neovac-SY and Santovac-5 are fairly resistant to oxidation and are used successfully around electronic devices. These oils polymerize into a conducting film when bombarded with electrons and thus do not promote static charge build-up. In addition, they are quite soluble and “clean up” easily. Neovac-SY has the advantage of economy while Santovac-5 is more durable and has a lower vapor pressure.

TECHNICAL NOTES

For additional oxidation resistance, many applications lend themselves to the use of silicone fluids. These are phenyl siloxane compounds that polymerize as a non-conducting film that can allow static charge build-up and are difficult to clean up. There are many silicone fluids on the market, so Agilent recommends using those equivalent to DC-704 (see page 30) or their variants, depending on application.

Another extremely stable fluid under reactive conditions is the fluorinated polyphenyl ether (Fomblin® or Krytox). This oil is widely used in mechanical oil-sealed pumps where large amounts of oxygen are pumped. It is also suitable as a diffusion pump fluid where large quantities of oxygen or other reactive gases may be encountered.

Speed Measurements

Note: *The speed values in this catalog have been measured according to ISO Standard 1608/1. They differ from the values published in previous catalog editions strictly due to the change in testing methods. The design and performance of the pumps have not changed in any way – only the speed test method.*

For reference, the speed values from the previous catalog editions are included in the technical specifications table for each pump. The data is labeled “Pumping Speed”, AVS 4.1 (1963).

The pressure gage mounted in the test dome is located at a distance of 1/2 the diameter of the pump from the inlet plane, versus 1/4 the diameter in previous tests. Also, total pressure gages were used to measure the pressure and calculate speed, versus partial pressure gages.

Combined, these two changes in test method result in a measured speed approximately 40% lower than previously published values. The changes in test method do not affect maximum throughput measurements.

Pumping speed is measured by introducing a known, steady state flow of gas into a measuring dome of specified geometry and measuring the resulting pressure established in the dome. Figure 1 shows the experimental setup used by Agilent as recommended by the American Vacuum Society (Standard 4.1). Speed is determined by the AVS Standard as:

$$S = Q / (P - P_0),$$

where Q is the flow rate (throughput) and P₀ is the ultimate pressure prior to the experiment. All diffusion pump curves shown in the catalog are based on the use of DC704 diffusion pump fluid and the standard cold cap (unless otherwise noted). The speed curves are created by calculating the speed at increasing levels of gas throughput, allowing time between readings to ensure steady state conditions are reached.

Diffusion pumps exhibit different speeds for different gases. Thus, the speed of each gas is obtained by dividing the throughput of the gas by the partial pressure of the same gas in the dome. Unless otherwise noted, the speeds shown in this catalog are for air.

Measuring the speed of a diffusion pump installed in a vacuum system often gives different results since the geometry, surface area, construction materials, and most importantly, pressure measurement locations differ from the measuring dome.

Backstreaming Measurements

Primary backstreaming can be measured by relatively simple means for pumps without baffles or traps. AVS Standard 4.5 (Journal of Vacuum Science and Technology, Volume 8, Number 5.) recommends the test dome configuration shown in Figure 2. The backstreaming rates published in Agilent’s catalog are measured using this technique. Any molecules which cross the pump inlet in the upward direction and condense in the dome may be said to be backstreaming.

The condensed pumping fluid collects in the trough around the periphery of the dome and drains into a measuring tube. Usually, it takes several days to collect sufficient fluid for satisfactory measurements. Regular volumetric measurements are taken and recorded on a volume versus time graph until the rate is observed to be steady ($\pm 10\%$) for at least 72 hours. The backstreaming rate is the average slope of the Volume-Time curve in the 72 hour time period. Note that this test will ignore “spikes” in the backstreaming rate, which may occur during startup, since only the volume collected during the steady-state, 72-hour

Figure 1

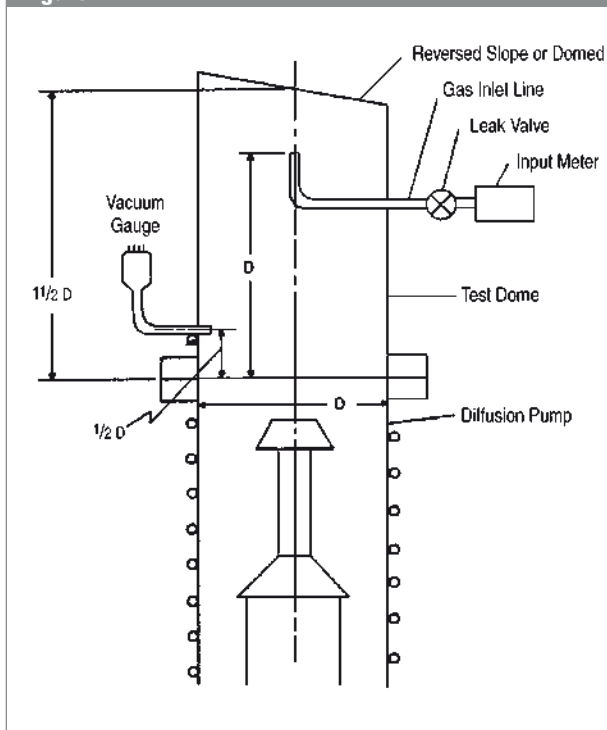

DIFFUSION PUMPS

period is considered. All backstreaming tests were performed using DC-704 pumping fluid (no longer available).

The measured backstreaming rate is very dependent on the test method used. If any method other than the dome method described above is used, the results can differ significantly from published values. Note also that the reported backstreaming values are valid for the normal operating range of the pump, at a pressure well below the point at which the top jet starts to break down (i.e. below the “knee” of the speed curve, where the speed is no longer constant with pressure). Above this critical pressure the backstreaming rate may rise markedly.

Backstreaming measurements above the baffle cannot be made with the standard test apparatus. The rates are so low that the collecting surfaces must be refrigerated to prevent re-evaporation, and the collection surface must be designed to collect smaller amounts of fluid.

Using Baffles to Reduce Backstreaming

If the vacuum system has intolerance to backstreaming, a baffle or trap should be considered. Too often a system designer will forego the use of baffles to reduce system cost, only to find the normal amount of backstreaming from the diffusion pumps is too high for the application. This is usually the case for high quality coating applications. The choice of baffle type is a trade-off between backstreaming level, net

pumping speed, size, and cost. The designer can choose a water-cooled halo baffle, water-cooled optically dense baffle, or a cryotrap. A diffusion pump can be ordered with a cold cap or a halo baffle (which has an integral cold cap). If an external baffle is to be used, the diffusion pump is typically ordered with a cold cap.

A water-cooled halo baffle is designed to intercept a majority of the primary backstreaming which escapes the cold cap. A cooled ring, or halo, is strategically placed where most of the backstreaming occurs. The rate is reduced by approximately 90% with a corresponding reduction in speed of roughly 40%. The actual reduction in backstreaming and speed depends on the type of pump and the application conditions. A water-cooled, optically tight baffle is designed to intercept 100% of the primary backstreaming, so what remains is secondary backstreaming. The temperature of the baffle surface, rather than the baffle geometry, determines the secondary backstreaming rate. Thus the choice of baffle becomes a trade-off between size (height), conductance, and cost.

A cryotrap, or liquid nitrogen trap, has a liquid nitrogen reservoir and various baffling surfaces. The reservoir is insulated from the environment by an evacuated space. The LN2 boils off to atmosphere through a vent port. Since LN2 boils at $-196\text{ }^{\circ}\text{C}$, the trap’s internal surfaces are extremely cold. In systems with liquid nitrogen traps, the backstreaming level can be controlled at such a low level that contaminants from sources other than the diffusion pump will predominate.

Estimating the Effect a Baffle Has on the Speed of the Pump

The degree to which a baffle will reduce the effective pumping speed of a diffusion pump depends on its conductance, which is a function of its geometry. Manufacturers either publish conductance values in L/s or provide an estimate of the retained pumping speed (e.g. “Retains 50% of pumping speed”). When a conductance value for the baffle, C_{baffle} , is published, an estimate of the effective pumping speed, S_{eff} , is given by:

$$S_{\text{eff}} = (C_{\text{baffle}} * S_{\text{pump}}) / (C_{\text{baffle}} + S_{\text{pump}})$$

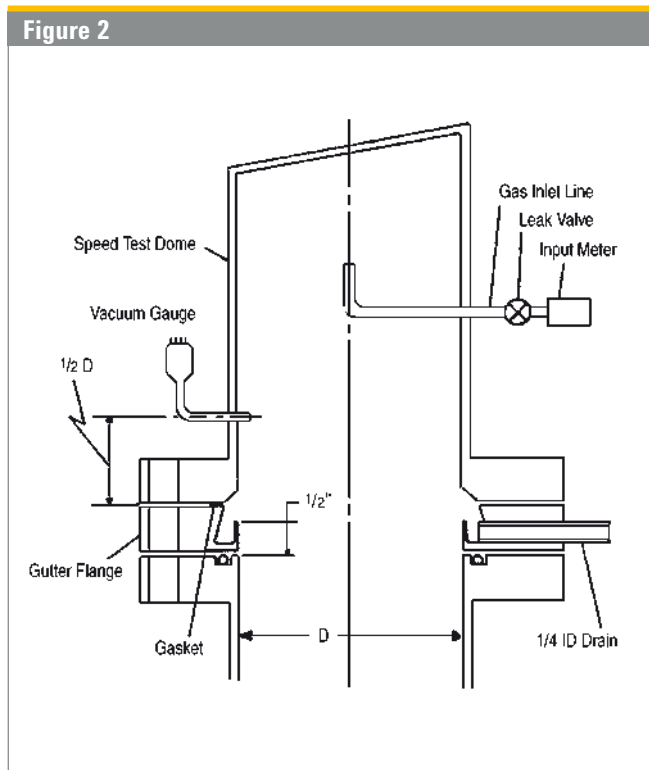



AGILENT ION PUMPS

2-3	Ion Pumps Features and Benefits
4,5	Controllers Features and Benefits
6,7	SEM Pump Controller Features and Benefits
8-11	Typical Applications
12-40	Pump Models and Controllers
41-51	Technical Notes
52-53	Service and Support Plan



Agilent Technologies

AGILENT ION PUMPS FEATURES AND BENEFITS

Ion Pump Evolution

- Since the late 1950's, when the ion pump was invented at Varian, now Agilent Technologies, many changes and technical improvements have taken place.

Virtually all of the major innovations have come from us, from the first Diode Vaclon pump to the Triode, then to the StarCell series pumps, and the Vaclon *Plus*.



Vaclon *Plus*

- Vaclon *Plus* is a complete family of ion pumps, controllers, options, and accessories, designed to provide solutions to every application. Parameters such as operating pressure, the gas mixture to be pumped, the starting pressure, etc. can vary so dramatically that Varian, today Agilent, decided to develop dedicated ion pump solutions (including controllers and all other accessories) for different applications.
- The Vaclon *Plus* family includes Diode, Noble Diode, and StarCell pump versions that allow Agilent to provide the best technology for each field of application. The family is complemented by the new 4UHV Ion Pump controllers, that provide different power levels and interface capabilities.

Titanium Sublimation Combination Pumps (TSP)

- The titanium sublimation creates extra high getterable gas pumping speed while the ion pumping mechanisms handle the non-getterable gases such as argon and methane. The combination pump includes the cylindrical cryopanel and TSP source mounted to the extra port. Customized pump configurations are also available.



Wide Pumping Speed Range

- Miniature/Appendage pumps from 0.2 to 10 l/s
- Small/Medium pumps from 20 to 75 l/s
- Large size pumps from 150 to 2500 l/s
- TSP/Combi pumps
- Custom solutions with special pumping speed, size, magnetic field



Vacuum Processing

In order to ensure cleanliness, all pumps are:

- Factory processed at high temperature (450°) in ultra-high vacuum for a thorough outgassing of the body and all internal components
- Shipped under vacuum, and an RGA spectrum can be provided with each pump
- HE-Leak check



Application Specific Solutions

for SEM: a complete line of ion getter pumps dedicated to Electron Microscopy.



Element Cells and Insulators

- Cells' sizes and geometries are optimized in order to:
 - maximize the discharge intensity
 - maximize the pumping speed
- The special design of the ceramic insulators allows:
 - no buildup of sputtered conductive coating
 - longer pump life

ION PUMPS



Custom Design

The pump body can be configured to meet optional requirements including:

- Cryopanel and TSP side or bottom mounted
- Integral heaters
- Additional roughing ports

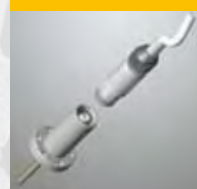

Feedthroughs

- Eliminate corrosion
- Implement the "High Voltage Cable Interlock"
- Provide an easy connection
- Prevent unintentional extraction
- Minimize overall dimensions



Pumping Elements

Three different types of pumping elements are available to cover all possible gas mixtures and optimize the application specific performances:

- Diode
- Noble Diode
- Our unique StarCell

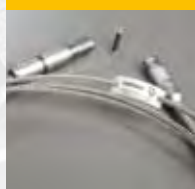

Cables

- Agilent cables have an "HV Safety Interlock" that prevents any chance of electrical shock
- If the cable is disconnected from the pump, the voltage is automatically cut off
- Available in different lengths
- Robust, flexible metal-shielded cable
- 10^7 Gy radiation tolerance



Heaters

- The pump can be supplied with heaters designed to perform the pump baking
- Minimize operational costs

THE NEW AGILENT 4UHV ION PUMP CONTROLLER FEATURES AND BENEFITS

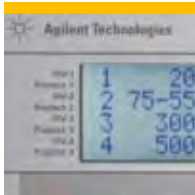

Versatility

The 4UHV is available in different configurations, in order to independently power, control and monitor any combination of multiple pumps of different sizes, from one to four pumps, from 10 to 2500 l/s. For each number of pumps to be operated several options are available, 120 W or 200 W for a single pump, 2 x 80 W or 2 x 200 W for two pumps, 2 x 80 + 200 W for three pumps, 4 x 80 W for four pumps.



Intelligence

To access the unit you can use analog or RS232/485 ports. The controller uses the same protocol as our other intelligent vacuum devices (Navigator turbo pump Controller and Inverter scroll & rotary vane pumps), giving you fast, convenient access to all elements of the vacuum system. Profibus and Ethernet communications available on request, please call Agilent for details.

More Choice and Flexibility

- The Vaclon *Plus* pump family is complemented by the new 4UHV Ion Pump controller, that provides different power levels and interface capabilities.
- The compact MiniVac controller and a dedicated TSP controller are also available.
- The new series of IPCU controller units completes Agilent's offer (see next pages).
- The existing range of ion pump controllers offers more choice and flexibility than ever before. With the latest in design features, they are simple and easy to operate; just select the right controller to fit your specific application.

4UHV - For Ultra High Vacuum

The new state-of-the-art Agilent 4UHV Ion Pump Controller operates up to four pumps simultaneously and independently. The 4UHV starts and controls ion pumps of any type (Diode, Noble Diode, StarCell) and size (from 10 to 2500 l/s). A large four-line LCD display allows simultaneous reading of individual pump voltage, current and pressure. The variable voltage feature ensures optimum pumping speed and pressure reading throughout the operating pressure range. Built-in set points, remote operation and RS232/485 computer interface are standard. Ethernet and Profibus are options.

Optimized Pumping Speed

The 4UHV will select the right operating voltage to optimize the pumping speed of your ion pumps. By applying High Voltage in accordance with operating pressure, pumping speed performance is improved. This is because the energy with which the ion bombards the cathode is the nominal

applied HV, reduced by the space charge effect due to the electron cloud present in the ion pump cell. Since the space charge effect is pressure related, a variable HV is applied to maintain optimum bombardment energy, resulting in the best possible pumping performance at any pressure.

Pumping Speed vs Pressure at Different Voltages

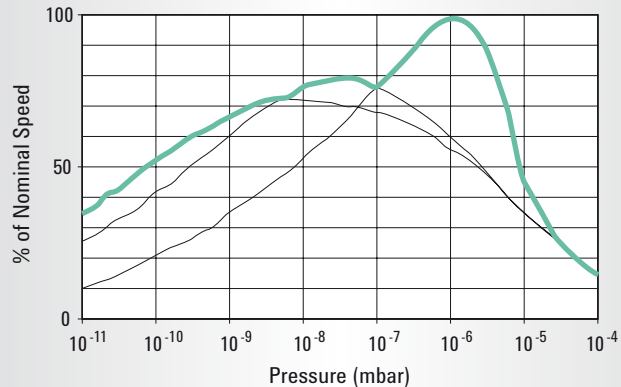

ION PUMPS



Low Noise

For SEM applications especially, the remaining AC component of the HV output was reduced to a minimum. It is much lower than in any other existing unit, eliminating the need for additional filters completely in many cases.

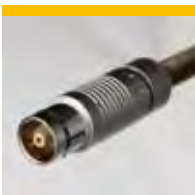

Safety

To protect you against high voltage the cable is equipped with an interlock system which immediately shuts down the high voltage when the plug is removed from the pump. The protect mode limits the current to protect the pump and the controller.



Pressure Reading

The 4UHV is preprogrammed to automatically convert current reading of any Vaclon Plus pump into pressure. Thanks to its ability to detect ion current as low as 10 nA, it allows pressure measurement in the 10^{-10} mbar range. To ensure reliable pressure reading down to the UHV region, the 4UHV optimizes the applied high voltage as a function of pressure. As a result, the leakage current of the ion pump is eliminated, thereby providing more accurate pressure readings.

Typical Current vs Pressure Curve

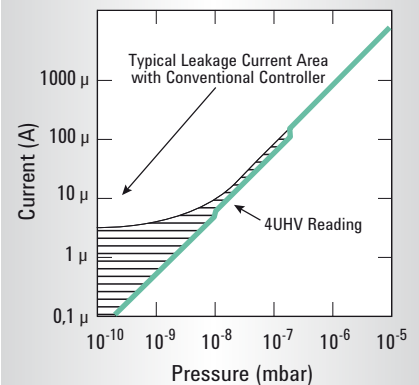

AGILENT SEM ION PUMPS FEATURES AND BENEFITS

The Agilent Advantage: Dedicated Solutions for SEM Applications

- Agilent is the only manufacturer to offer specially designed SEM ion pumps. These pumps are ideal for the high vacuum guns where stable vacuum and low leakage current is required to control and preserve the charged particle filament.
- The key to this superior performance is Agilent's patented anode design which uses contoured cells and simplified electrical elements. This insures stable current readings and lower particle generation.
- When combining the SEM ion pump on the gun with a StarCell ion pump on the lower column, Agilent ion pumps can offer a powerful combination optimised for modern E-beam columns.

SEM Ion Pumps are available on request; please ask Agilent for technical details.



Wide, Dedicated Range

- A complete range of SEM ion pumps from 10 to 75 l/s, tailored to your specific vacuum needs
- Small footprint for easier system integration



Dedicated Heaters

- Dedicated Heater for every pump size
- The new heaters are designed to perform a more effective pump baking
- Lower power and operational costs



Innovative SEM Anode Geometry

- Better current stability
- Lowest leakage current in the industry (< 10 nA)
- Double Shielded Ceramics
- Longer pump life
- Longer pressure stability
- Maximum uptime



Very Compact Design

Improved design for:

- Lighter pump weight
- Fast magnets replacement
- Easy maintenance



IPC3 / IPCU 2 Power Supplies

Two versions: 3 or 2 supply channels

- Special low noise electronics for better SEM imaging
- Battery backup (optional): up to 30 days 24/7 of battery life
- Optional display and front panel

New 4UHV Controller

- Special low noise electronics for better SEM imaging

ION PUMPS

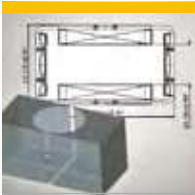

Dedicated Magnetic Stray Shields

- External magnetic shields for stray magnetic field reduction available individually on request

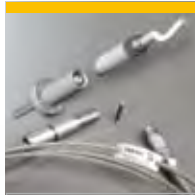

Agilent Feedthrough and Cables

- The HV Safety Interlock prevents any chance of electrical shock
- The voltage is automatically cut off as soon as the cable is disconnected from the pump
- Safer pump operation

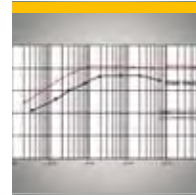

Higher Pumping Speed

- Optimized magnetic circuit for max. performance in a very compact package
- Faster pump down



Available in Round Shape

Integrated ion pump/column allows:

- Optimum mass balancing
- Improved pumping conductance
- Compact and modular design
- Symmetric weight distribution for rugged column integration



RGA Guaranteed Ultimate Vacuum

- The pump is vacuum processed at 450 °C to outgas most of gases out of the pump body
- The pump is shipped under vacuum
- An RGA (Residual Gas Analysis) spectrum is available for each pump, to guarantee its performance and the cleanliness of the manufacturing process

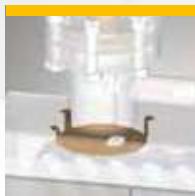

Optical Baffle

Built-in Optical Baffle (optional) for:

- Minimized particle emission
- Minimum conductance reduction
- Total column protection
- Maximum e-gun life



Battery Power Supply

- Enables service without breaking vacuum
- Allows for column shipping under vacuum

Ion Pumps

TYPICAL APPLICATIONS FOR AGILENT VACLON *PLUS* PUMPS



Courtesy: LBNL Advanced Light Source.



Courtesy PSI SLS.

Research and Development

Particle Accelerators & Synchrotron Light Sources

In these machines, electrically charged particles (electrons for the production of synchrotron light or ions for particle accelerators) are forced to follow a curved trajectory in a ring called a storage ring. Charged particles circulate for hours in the storage ring, at constant energy, in an ultra-high vacuum environment.

Before their injection into the storage ring, the particles first have to be accelerated inside an injection system composed of one or two accelerators (the Linac and the Booster). All along their path within the machine, the particles (electrons or ions) have to circulate inside a vacuum chamber. Otherwise, they would collide with the air molecules and would be absorbed very rapidly.

- **Linac**

The linac is a linear accelerator. The charged particles enter into a first RF cavity which accelerates them and at the same time groups them into bunches. They are then accelerated by a succession of RF cavities throughout the length of the linac. Vacuum within the linac can be created by Agilent Vaclon *Plus* pumps from 20 l/s to 70 l/s.

- **Booster**

Charged particles, which have already been accelerated in the linac, are accelerated even more strongly by the booster. The acceleration is produced by RF cavities through which the charged particles pass many times, gaining in energy at each pass. Once the level of maximum energy has been reached, the beam of particles is transferred from the booster to the storage ring. Vacuum in the booster is generally produced by small pumps. Small Agilent Vaclon *Plus* pumps fit this application perfectly.

- **Storage Ring**

Charged particles circulate inside the storage ring at constant energy. All along the ring there are curved sections as well as straight sections. The storage ring is placed inside a tunnel with very thick concrete walls in order to contain emitted radiation in case of beam loss. Ultra high vacuum is an absolute necessity in this part of the machine since the particles travel through the storage ring for hours. The less residual gas there is, the more focused the beam remains. Large Agilent Vaclon *Plus* pumps, in the 300 - 500 l/s range are used for this demanding application.

- **Front Ends**

The front end is the pipe work which transports the particles under a vacuum from the extraction zone up to the beamline outside of the tunnel of the ring. There you can find a beam shutter as well as devices allowing the isolation of the vacuum of the ring from that of the beamline, which is often of lower pressure. Agilent large pumps, as in for the storage ring, can be used in this part of the machine.



Courtesy of MedAustron.

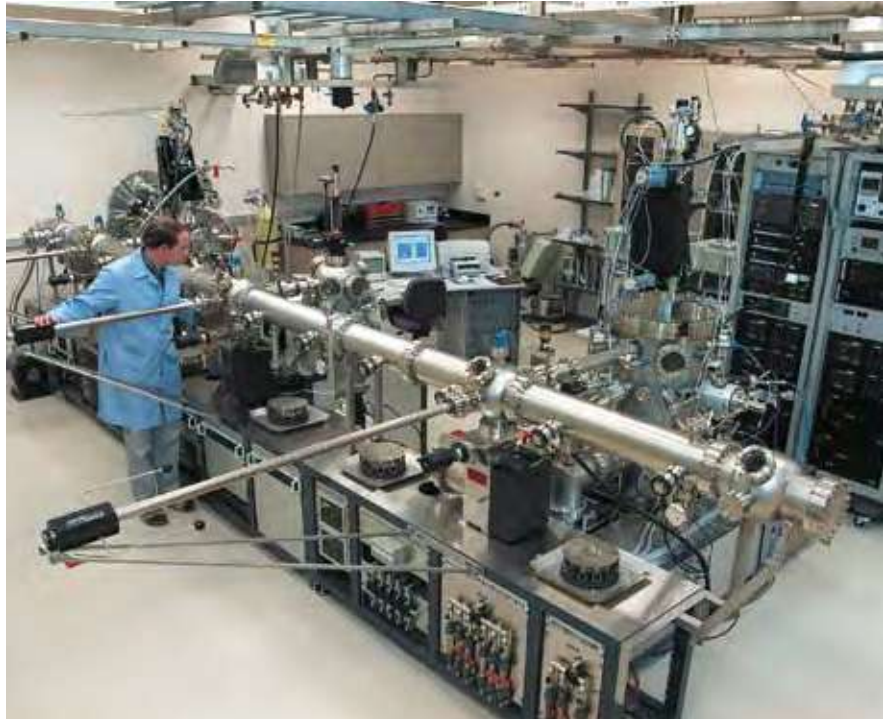

Courtesy Pacific Northwest National Laboratory.

- **Beam Lines**

The experimental hall, around the storage ring, houses the beamlines built tangentially to the ring. The beamlines are usually specialized in a field of research (such as biology, polymers, and magnetism) or an experimental method (such as diffraction, EXAFS, and imaging). Some of the longest beamlines are built outside the experimental hall. Generally, large pumps are used in this part, from 300 l/s to 500 l/s. They can be combined with TSP and cryopanel in order to pump even the lightest molecules.

- **Miscellaneous Projects**

Some fundamental research projects that use very sensitive equipment (necessitating ultra-high vacuum with no mechanical vibration) will find the solution in Agilent Vaclon *Plus* pumps. The new gravitational waves detectors (GWD) such as VIRGO in Italy and LIGO in the USA use Agilent pumps to produce and maintain the required vacuum.



Courtesy P. Ginter - ESRF Grenoble.



Courtesy P. Ginter - ESRF Grenoble.

AGILENT ION PUMPS TYPICAL APPLICATIONS

Mass Spectrometry

- Analytical systems that use focused charged particle beams (CPB) and certain types of mass spectrometers such as magnetic sector or Fournier Transfer often require ultra-high vacuum.
- These applications have very stringent performance requirements for sensitivity, resolution, sample throughput and measurement repeatability. These requirements are driven by the need to analyze ever-smaller samples, especially in semiconductor, manufacturing, and other high-tech applications.
- In general these applications require very clean vacuum pumping, and only Vaclon pumps can certify the required level of cleanliness because Agilent is the only ion pump manufacturer that bakes each pump in a vacuum furnace, and supply each pump with an RGA scan.
- Agilent offers a full range of pumps, from 0.2 l/s up to 2500 l/s, as well as combination and custom pumps so analytical system designers can meet all their vacuum requirements from one supplier.
- Over 50 years of ion pump experience makes Agilent uniquely qualified to supply customized solutions for special applications.



Nanotechnologies

- Agilent's line of high performance Vaclon ion pumps are well suited for the vacuum requirements of Transmission Electron Microscopes (TEM), Scanning Electron Microscopes (SEM), Focused Ion Beam (FIB) and Surface Analysis equipments.
- **Agilent is the only manufacturer to offer SEM application-specific ion pumps with unique anode design**
- The Diode SEM pump with its extremely low leakage current is ideal for the gun section of the column.
- The StarCell pump element with its unique design is the ideal solution for the high pressure operation of the columns. StarCell is also the best pump for noble gases or hydrogen.
- Agilent completes its offering to the microscope manufacture with a full line of controller/power supplies including the low cost power supplies and the full feature, multiple controllers.
- With the addition of Agilent complete line of oil-free, low vibration turbo pumps - ideal for sample chamber vacuum requirements – roughing pumps and vacuum gauges, Agilent can supply all the vacuum components required for electron microscopes.



Industrial Vacuum Processes

Different applications in industrial sectors such as telecommunication, defense, medical and others make use of Vaclon pumps to process and maintain essential components under vacuum. Most of the core equipment in these sectors requires the use of different electron devices including:

- **Microwave tubes and devices**
- **Power grid tubes**
- **X-ray imaging tubes and devices**
- **X-ray sources**

In the processing cycle of these types of electron devices, small ion pumps from 10 l/s to 50 l/s are being used. Special tube sizes or special applications may require even bigger ion pumps up to 300-500 l/s. Vaclon pumps are often being used in combination with Turbo Molecular Pumps, backing pumps and other components out of the wide range of Agilent products.

After processing, frequently these electron devices are being equipped with so-called appendage ion pumps in the range of 0.2 l/s to 10 l/s for the purpose of maintaining the electron tube under vacuum for its operational lifetime.

The first ion pump was invented in the late 1950's, for the production of high-quality vacuum tubes used in radar technology. From this point on, Vaclon pumps set the pace in

ION PUMPS

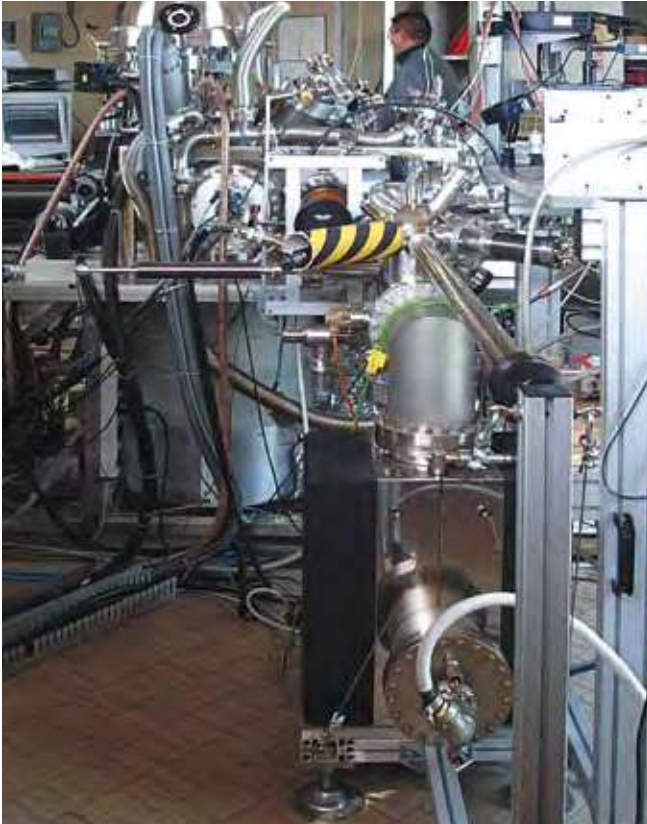

Courtesy University of Modena.



Courtesy CPI.

the industrial field for a wide range of applications using vacuum processed electron devices used worldwide in:

- **Space**

Electron devices are essential to various space programs, from satellite services and earth observation satellites to space probes. Microwave tubes and devices are vital tools, which link people and satellites in order to enable global communications. Spaceborne tubes are the power generators for the transponders carried on satellites. They retransmit TV or telecommunication signals back to the ground. The electron tubes used for this application are Travelling Wave Tubes. In these tubes, amplification is produced under vacuum by the interaction between a beam of electrons and the Radio-Frequency (RF) wave.

- **Telecommunications**

Microwave tubes, devices like Traveling Wave Tubes (TWTs) and Klystrons (powerful radio vacuum tubes) are widely used in civil and military telecommunication networks and equipment used for:

- Satellite and terrestrial communication
- High data-rate transmissions for High Speed Internet and Wireless Cable
- Broadband high speed data
- Point-to-point and point-to-multipoint microwave links.

- **Broadcast**

Radio and TV broadcasters and transmitter manufacturers use electron devices in their equipment to enable high power transmission or digital broadcasting. Power grid tubes or microwave tubes are being used in AM radio, FM radio, VHF TV, UHF TV or digital TV transmitters and amplifiers.

- **Medical**

Radiological equipment manufacturers use electron devices for critical components in the radiological chain, such as X-ray image intensifiers and radiological imaging units for diagnostics, as well as medical linear accelerators for radiation therapy. Typical fields of application include:

- Medical Imaging (X-ray image tubes and devices)
- Radiation Therapy (high power Klystrons, LINAC)
- Magnetic Resonance Imaging.

- **Defense**

Microwave tubes and devices are key components in equipment and systems used for different defense applications:

- Radar (ground based or airborne)
- Electronic Countermeasures (ECM)
- Smart Weapons & Electronic Warfare
- Missile guidance & Missile seekers

- **Industrial and Others**

Several industrial processes make use of RF & Microwave tubes. Some examples are heat treating, Plastic welding, Food processing, Textile manufacturing, Film curing & drying. Other applications make use of X-ray tubes for non-destructive testing methods.

AGILENT ION PUMP MODELS

	Miniature Pump	2 l/s Pump	10 l/s Pump	Vaclon Plus 20		
Inlet flange				2 3/4" OD CFF (NW 35)		
Element type	Diode	Diode	Diode	Star Cell	Noble Diode	Diode
Pumping speed (l/s) (saturated pump at 1 ⁻⁶ mbar) Nitrogen	0.2	2	10	20	22	27
Operating life (hours) (at 1 ⁻⁶ mbar)	N/A	8,000	40,000	80,000	50,000	50,000
Maximum starting pressure (mbar)	1 x 10 ⁻⁴	1 x 10 ⁻⁴	≤ 1 x 10 ⁻⁴	<10 ⁻²	<10 ⁻³	<10 ⁻³
Maximum baking temperature (°C)	400 (without magnet) 150 (with magnet)	400 (without magnet) 150 (with magnet)	350	350	350	350
Weight kg (lbs)	Net 0.3 (0.66) Shipping 0.6 (1.33)	Net 0.3 (0.66) Shipping 0.6 (1.33)	Without magnet 4 (9)	Net 7 (15) Shipping 11 (24)		
SEM version available on request	-	-	+	+		



ION PUMPS

Vaclon Plus 40			Vaclon Plus 55			Vaclon Plus 75			Vaclon Plus 150			Vaclon Plus 300			Vaclon Plus 500		
2 ¾" OD CFF (NW 35)			4 ½" OD CFF (NW 63)			6" OD CFF (NW 100)			6" OD CFF (NW 100)			8" OD CFF (NW 150)			8" OD CFF (NW 150)		
Star Cell	Noble Diode	Diode	Star Cell	Noble Diode	Diode	Star Cell	Noble Diode	Diode	Star Cell	Noble Diode	Diode	Star Cell	Noble Diode	Diode	Star Cell	Noble Diode	Diode
34	36	40	50	53	55	65	68	75	125	135	150	240	260	300	410	440	500
80,000	50,000	50,000	80,000	50,000	50,000	80,000	50,000	50,000	80,000	50,000	50,000	80,000	50,000	50,000	80,000	50,000	50,000
<10 ⁻²	<10 ⁻³	<10 ⁻³	<10 ⁻²	<10 ⁻³	<10 ⁻³	<10 ⁻²	<10 ⁻³	<10 ⁻³	<10 ⁻²	<10 ⁻³	<10 ⁻³	<10 ⁻²	<10 ⁻³	<10 ⁻³	<10 ⁻²	<10 ⁻³	<10 ⁻³
350	350	350	350	350	350	350	350	350	350	350	350	350	350	350	350	350	350
Net 17 (37) Shipping 21 (46)			Net 18 (39) Shipping 22 (48)			Net 19 (42) Shipping 23 (51)			Net 43 (94) Shipping 53 (110)			Net 69 (149) Shipping 84 (185)			Net 120 (264) Shipping 135 (297)		
+			+			+			-			-			-		



Ion Pumps

AGILENT ION PUMP MODELS

▶ Agilent Vaclon Plus 20

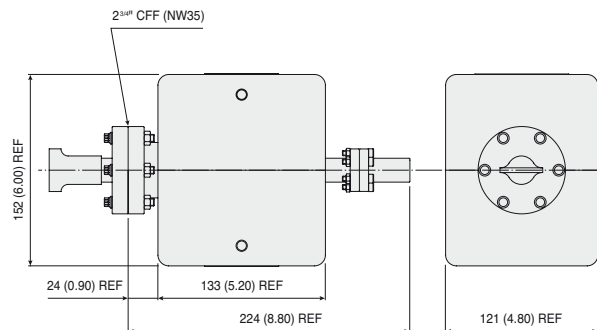

Dimensions: millimeters (inches)

Technical Specifications

	StarCell	Noble Diode	Diode
Nominal pumping speed for Nitrogen (*) (l/s)	20	22	27
Operating life at 1×10^{-6} mbar (hours)	80,000	50,000	50,000
Maximum starting pressure (mbar)	$\leq 5 \times 10^{-2}$	$\leq 1 \times 10^{-3}$	$\leq 1 \times 10^{-3}$
Ultimate pressure	Below 10^{-11}		
Inlet flange	2 3/4" CFF (NW 35) AISI 304 ESR SST		
Maximum baking temperature (°C)	350		
Weight, kg (lbs) (with ferrite magnet)	Net 7 (15), Shipping 11 (24)		

(*) Tested according to ISO/DIS 3556-1-1992

SEM version available on request

Vaclon Plus 20 - Pumping Speed vs Pressure

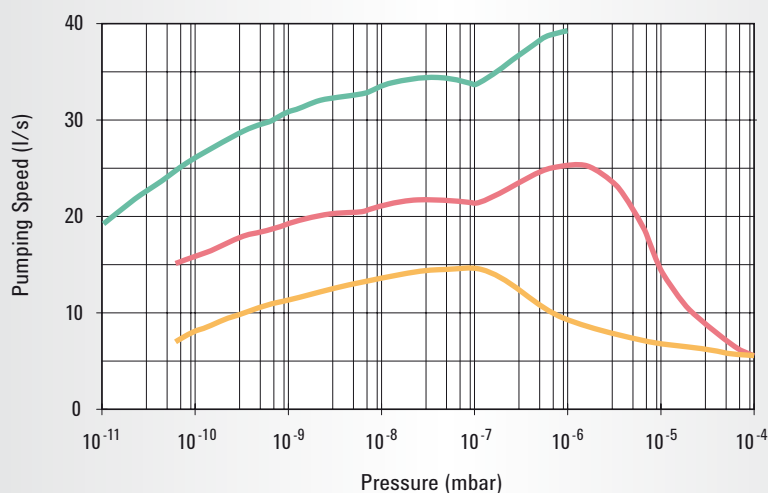

— Nitrogen unsaturated Diode — Nitrogen saturated Diode — Argon saturated StarCell

Ordering Information

Description	Part Number
Pumps	
Diodewith Ferrite magnets	9191115
Diode without magnets	9191114
StarCell with Ferrite magnets	9191145
StarCell with Sm-Co magnets	9191146
StarCell without magnets	9191144
<i>Noble Diode versions available on request</i>	
4UHV Controller	
120 W negative	9299100
120 W positive	9299101
200 W neg	9299010
200 W pos	9299011
2 x 80 W neg	9299200
2 x 80 W pos	9299201
2 x 200 W neg	9299020
2 x 200 W pos	9299021
1 x 200 W pos & 1 x 200 W neg	9299022
4 x 80 W neg	9299400
4 x 80 W pos	9299401
2 x 80 W pos & 2 x 80 W neg	9299402
2 x 80 W neg & 1 x 200 W neg	9299210
2 x 80 W pos & 1 x 200 W pos	9299211
2 x 80 W pos & 1 x 200 W neg	9299212
2 x 80 W neg & 1 x 200 W pos	9299213

Description	Part Number
HV Cables	
HV Bakeable cable, radiation resistant, 4 m (13 ft.) long, with interlock	9290705
HV Bakeable cable, radiation resistant, 7 m (23 ft.) long, with interlock	9290707
HV Bakeable cable, radiation resistant, 10 m (33 ft.) long, with interlock	9290708
HV Bakeable cable, radiation resistant, 20 m (66 ft.) long, with interlock	9290709

Replacement Parts		
HV Feedthrough with interlock		9595125
Vaclon Plus 20 Diode Ferrite magnet assembly		9191001
Vaclon Plus 20 Noble Diode Ferrite magnet assembly		9191002
Vaclon Plus 20 StarCell Ferrite magnet assembly		9191004
Heaters* (Input Power 140 W)	120 V	9191110
Heaters* (Input Power 140 W)	220 V	9191111

* To order heaters for replacement or upgrading of existing pumps, please contact your local Agilent Vacuum Technologies representative.

Diode, Noble Diode	positive
StarCell, Triode	negative
(see page 42)	

AGILENT ION PUMP MODELS

▶ Agilent Vaclon Plus 40

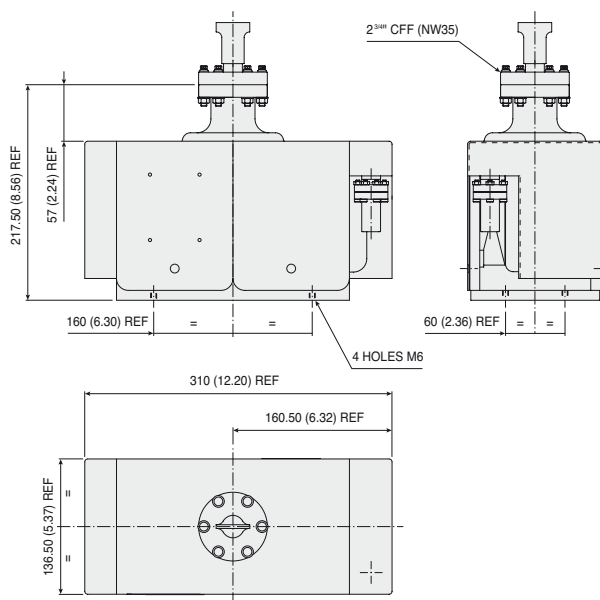

Dimensions: millimeters (inches)

Technical Specifications

	StarCell	Noble Diode	Diode
Nominal pumping speed for Nitrogen (*) (l/s)	34	36	40
Operating life at 1×10^{-6} mbar (hours)	80,000	50,000	50,000
Maximum starting pressure (mbar)	$\leq 5 \times 10^{-2}$	$\leq 1 \times 10^{-3}$	$\leq 1 \times 10^{-3}$
Ultimate pressure		Below 10^{-11}	
Inlet flange	2 3/4" CFF (NW 35) AISI 304 ESR SST		
Maximum baking temperature (°C)		350	
Weight, kg (lbs)		17 (37)	

(*) Tested according to ISO/DIS 3556-1-1992

SEM version available on request

Vaclon Plus 40 - Pumping Speed vs Pressure

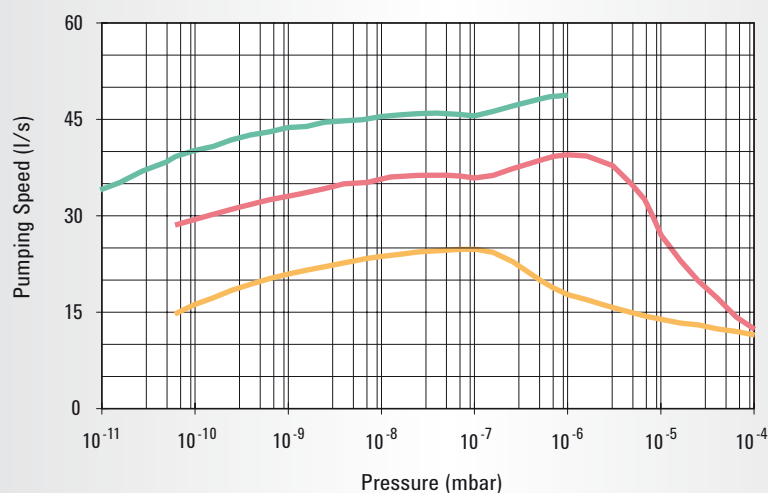

— Nitrogen unsaturated Diode — Nitrogen saturated Diode — Argon saturated StarCell

Ordering Information

Description	Part Number
Pumps	
Diode	9191210
Diode with additional 2 ¼" CFF port	9191213
Diode without magnets	9191214
StarCell	9191240
StarCell with additional 2 ¼" CFF port	9191243
StarCell without magnets	9191244

Noble Diode versions available on request

4UHV Controller	
120 W negative	9299100
120 W positive	9299101
200 W neg	9299010
200 W pos	9299011
2 x 80 W neg	9299200
2 x 80 W pos	9299201
2 x 200 W neg	9299020
2 x 200 W pos	9299021
1 x 200 W pos & 1 x 200 W neg	9299022
4 x 80 W neg	9299400
4 x 80 W pos	9299401
2 x 80 W pos & 2 x 80 W neg	9299402
2 x 80 W neg & 1 x 200 W neg	9299210
2 x 80 W pos & 1 x 200 W pos	9299211
2 x 80 W pos & 1 x 200 W neg	9299212
2 x 80 W neg & 1 x 200 W pos	9299213

Description	Part Number
HV Cables	
HV Bakeable cable, radiation resistant, 4 m (13 ft.) long, with interlock	9290705
HV Bakeable cable, radiation resistant, 7 m (23 ft.) long, with interlock	9290707
HV Bakeable cable, radiation resistant, 10 m (33 ft.) long, with interlock	9290708
HV Bakeable cable, radiation resistant, 20 m (66 ft.) long, with interlock	9290709

Replacement Parts		
HV Feedthrough with interlock		9595125
Heaters*/** (Input Power 250 W)	120 V	9190071
Heaters*/** (Input Power 250 W)	220 V	9190070

* To order heaters for replacement or upgrading of existing pumps, please contact your local Agilent Vacuum Technologies representative.

** cCSAus marked version available on request.

Diode, Noble Diode	positive
StarCell, Triode	negative
(see page 42)	

AGILENT ION PUMP MODELS

▶ Agilent Vaclon Plus 55

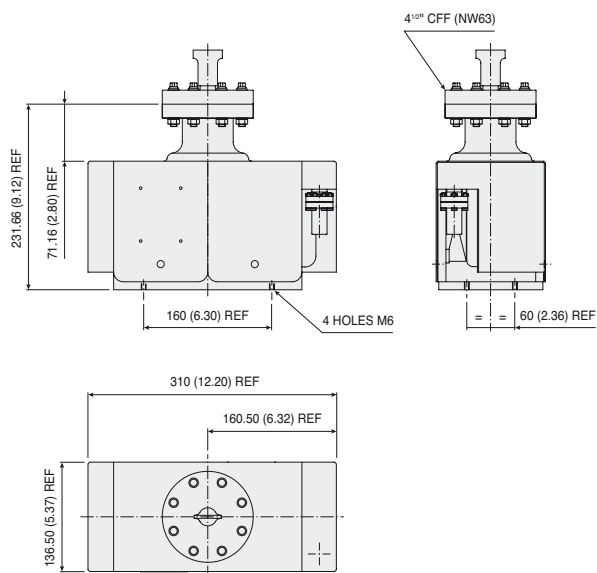

Dimensions: millimeters (inches)

Technical Specifications

	StarCell	Noble Diode	Diode
Nominal pumping speed for Nitrogen (*) (l/s)	50	53	55
Operating life at 1×10^{-6} mbar (hours)	80,000	50,000	50,000
Maximum starting pressure (mbar)	$\leq 5 \times 10^{-2}$	$\leq 1 \times 10^{-3}$	$\leq 1 \times 10^{-3}$
Ultimate pressure		Below 10^{-11}	
Inlet flange	4 3/4" CFF (NW 63) AISI 304 ESR SST		
Maximum baking temperature (°C)		350	
Weight, kg (lbs)		18 (39)	

(*) Tested according to ISO/DIS 3556-1-1992

SEM version available on request

Vaclon Plus 55 - Pumping Speed vs Pressure

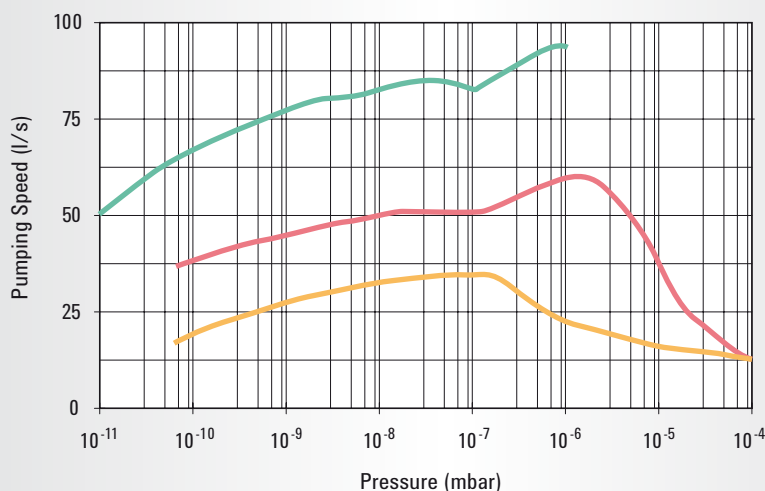

— Nitrogen unsaturated Diode — Nitrogen saturated Diode — Argon saturated StarCell

Ordering Information

Description	Part Number
Pumps	
Diode	9191310
Diode with additional 2 ¼" CFF port	9191313
Diode without magnets	9191314
StarCell	9191340
StarCell with additional 2 ¼" CFF port	9191343
StarCell without magnets	9191344

Noble Diode versions available on request

4UHV Controller	
120 W negative	9299100
120 W positive	9299101
200 W neg	9299010
200 W pos	9299011
2 x 80 W neg	9299200
2 x 80 W pos	9299201
2 x 200 W neg	9299020
2 x 200 W pos	9299021
1 x 200 W pos & 1 x 200 W neg	9299022
4 x 80 W neg	9299400
4 x 80 W pos	9299401
2 x 80 W pos & 2 x 80 W neg	9299402
2 x 80 W neg & 1 x 200 W neg	9299210
2 x 80 W pos & 1 x 200 W pos	9299211
2 x 80 W pos & 1 x 200 W neg	9299212
2 x 80 W neg & 1 x 200 W pos	9299213

Description	Part Number
HV Cables	
HV Bakeable cable, radiation resistant, 4 m (13 ft.) long, with interlock	9290705
HV Bakeable cable, radiation resistant, 7 m (23 ft.) long, with interlock	9290707
HV Bakeable cable, radiation resistant, 10 m (33 ft.) long, with interlock	9290708
HV Bakeable cable, radiation resistant, 20 m (66 ft.) long, with interlock	9290709

Replacement Parts		
HV Feedthrough with interlock		9595125
Heaters*/** (Input Power 250 W)	120 V	9190071
Heaters*/** (Input Power 250 W)	220 V	9190070

* To order heaters for replacement or upgrading of existing pumps, please contact your local Agilent Vacuum Technologies representative.

** cCSAus marked version available on request.

Diode, Noble Diode	positive
StarCell, Triode	negative
(see page 42)	

AGILENT ION PUMP MODELS

▶ Agilent Vaclon Plus 75

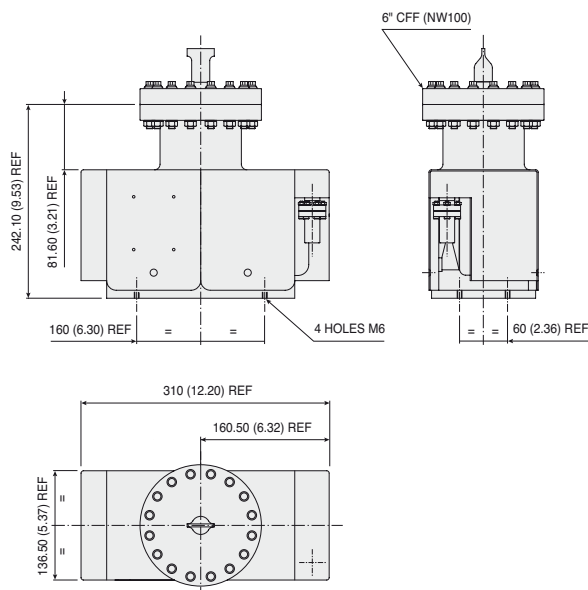

Dimensions: millimeters (inches)

Technical Specifications

	StarCell	Noble Diode	Diode
Nominal pumping speed for Nitrogen (*) (l/s)	65	68	75
Operating life at 1×10^{-6} mbar (hours)	80,000	50,000	50,000
Maximum starting pressure (mbar)	$\leq 5 \times 10^{-2}$	$\leq 1 \times 10^{-3}$	$\leq 1 \times 10^{-3}$
Ultimate pressure		Below 10^{-11}	
Inlet flange		6" CFF (NW 100) AISI 304 ESR SST	
Maximum baking temperature (°C)		350	
Weight, kg (lbs)		19 (42)	

(*) Tested according to ISO/DIS 3556-1-1992

SEM version available on request

Vaclon Plus 75 - Pumping Speed vs Pressure

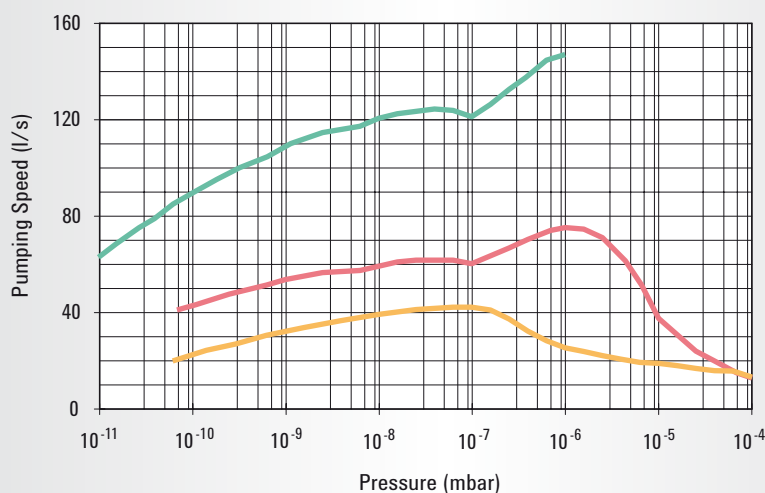

— Nitrogen unsaturated Diode — Nitrogen saturated Diode — Argon saturated StarCell

Ordering Information

Description	Part Number
Pumps	
Diode	9191410
Diode with additional 2 ¼" CFF port	9191413
Diode without magnets	9191414
StarCell	9191440
StarCell with additional 2 ¼" CFF port	9191443
StarCell without magnets	9191444

Noble Diode versions available on request

4UHV Controller	
120 W negative	9299100
120 W positive	9299101
200 W neg	9299010
200 W pos	9299011
2 x 80 W neg	9299200
2 x 80 W pos	9299201
2 x 200 W neg	9299020
2 x 200 W pos	9299021
1 x 200 W pos & 1 x 200 W neg	9299022
4 x 80 W neg	9299400
4 x 80 W pos	9299401
2 x 80 W pos & 2 x 80 W neg	9299402
2 x 80 W neg & 1 x 200 W neg	9299210
2 x 80 W pos & 1 x 200 W pos	9299211
2 x 80 W pos & 1 x 200 W neg	9299212
2 x 80 W neg & 1 x 200 W pos	9299213

Description	Part Number
HV Cables	
HV Bakeable cable, radiation resistant, 4 m (13 ft.) long, with interlock	9290705
HV Bakeable cable, radiation resistant, 7 m (23 ft.) long, with interlock	9290707
HV Bakeable cable, radiation resistant, 10 m (33 ft.) long, with interlock	9290708
HV Bakeable cable, radiation resistant, 20 m (66 ft.) long, with interlock	9290709

Replacement Parts		
HV Feedthrough with interlock		9595125
Heaters*/** (Input Power 250 W)	120 V	9190071
Heaters*/** (Input Power 250 W)	220 V	9190070

* To order heaters for replacement or upgrading of existing pumps, please contact your local Agilent Vacuum Technologies representative.

** cCSAus marked version available on request.

Diode, Noble Diode	positive
StarCell, Triode	negative
(see page 42)	

AGILENT ION PUMP MODELS

▶ Agilent Vaclon Plus 150

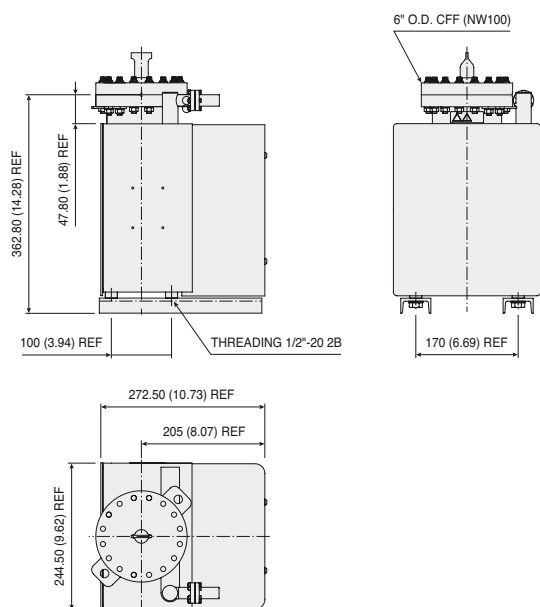

Dimensions: millimeters (inches)

Technical Specifications

	StarCell	Noble Diode	Diode
Nominal pumping speed for Nitrogen (*) (l/s)	125	135	150
Operating life at 1×10^{-6} mbar (hours)	80,000	50,000	50,000
Maximum starting pressure (mbar)	$\leq 5 \times 10^{-2}$	$\leq 1 \times 10^{-3}$	$\leq 1 \times 10^{-3}$
Ultimate pressure	Below 10^{-11}		
Inlet flange	6" CFF (NW 100) AISI 304 ESR		
Maximum baking temperature (°C)	350		
Weight, kg (lbs)	43 (94)		

(*) Tested according to ISO/DIS 3556-1-1992

Vaclon Plus 150 - Pumping Speed vs Pressure

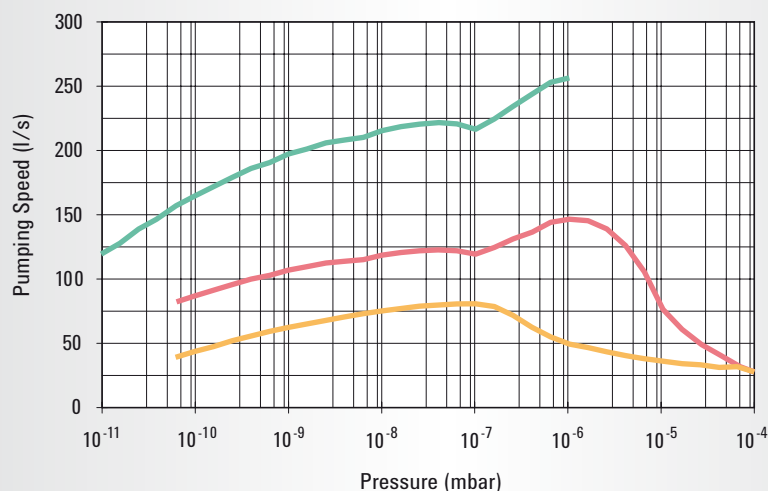

— Nitrogen unsaturated Diode — Nitrogen saturated Diode — Argon saturated StarCell

Ordering Information

Description	Part Number
Pumps	
Diode	9191510
Diode with heaters installed 120 V	9191511
Diode with heaters installed 220 V	9191512
Diode double-ended	9191550
Diode double-ended with heaters installed 120 V	9191551
Diode double-ended with heaters installed 220 V	9191552
StarCell	9191540
StarCell with heaters installed 120 V	9191541
StarCell with heaters installed 220 V	9191542
StarCell double-ended	9191580
StarCell double-ended with heaters installed 120 V	9191581
StarCell double-ended with heaters installed 220 V	9191582
<i>Noble Diode versions available on request</i>	
4UHV Controller	
120 W negative	9299100
120 W positive	9299101
200 W neg	9299010
200 W pos	9299011
2 x 80 W neg	9299200
2 x 80 W pos	9299201
2 x 200 W neg	9299020
2 x 200 W pos	9299021
1 x 200 W pos & 1 x 200 W neg	9299022
4 x 80 W neg	9299400
4 x 80 W pos	9299401
2 x 80 W pos & 2 x 80 W neg	9299402

Description	Part Number
4UHV Controller (cont'd)	
2 x 80 W neg & 1 x 200 W neg	9299210
2 x 80 W pos & 1 x 200 W pos	9299211
2 x 80 W pos & 1 x 200 W neg	9299212
2 x 80 W neg & 1 x 200 W pos	9299213
HV Cables	
HV Bakeable cable, radiation resistant, 4 m (13 ft.) long, with interlock	9290705
HV Bakeable cable, radiation resistant, 7 m (23 ft.) long, with interlock	9290707
HV Bakeable cable, radiation resistant, 10 m (33 ft.) long, with interlock	9290708
HV Bakeable cable, radiation resistant, 20 m (66 ft.) long, with interlock	9290709
Replacement Parts	
HV Feedthrough with interlock	9595125
Pumping element* Diode	9199040
Pumping element* Noble Diode	9199045
Pumping element* StarCell	9199030
Heaters** (Input Power 480 W) 120 V	9190073
Heaters** (Input Power 480 W) 220 V	9190072

* Quantity required: 2.

** To order heaters for replacement or upgrading of existing pumps, please contact your local Agilent Vacuum Technologies representative.

Diode, Noble Diode	positive
StarCell, Triode	negative
(see page 42)	

AGILENT ION PUMP MODELS

▶ Agilent Vaclon Plus 300

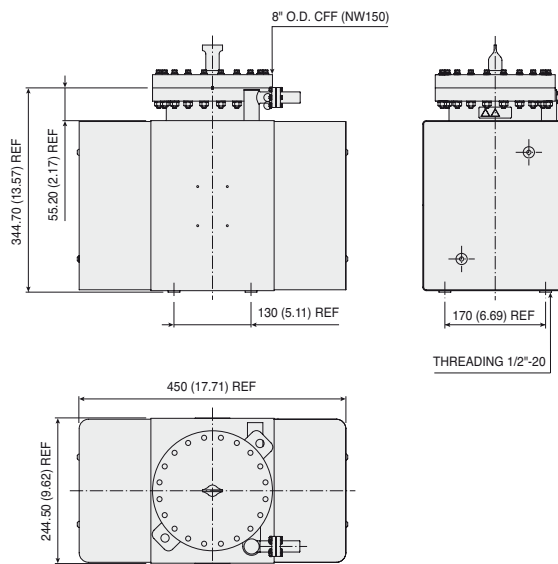

Dimensions: millimeters (inches)

Technical Specifications

	StarCell	Noble Diode	Diode
Nominal pumping speed for Nitrogen (*) (l/s)	240	260	300
Operating life at 1×10^{-6} mbar (hours)	80,000	50,000	50,000
Maximum starting pressure (mbar)	$\leq 5 \times 10^{-2}$	$\leq 1 \times 10^{-3}$	$\leq 1 \times 10^{-3}$
Ultimate pressure	Below 10^{-11}		
Inlet flange	8" CFF (NW 150) AISI 304 ESR		
Maximum baking temperature (°C)	350		
Weight, kg (lbs)	69 (149)		

(*) Tested according to ISO/DIS 3556-1-1992

Vaclon Plus 300 - Pumping Speed vs Pressure

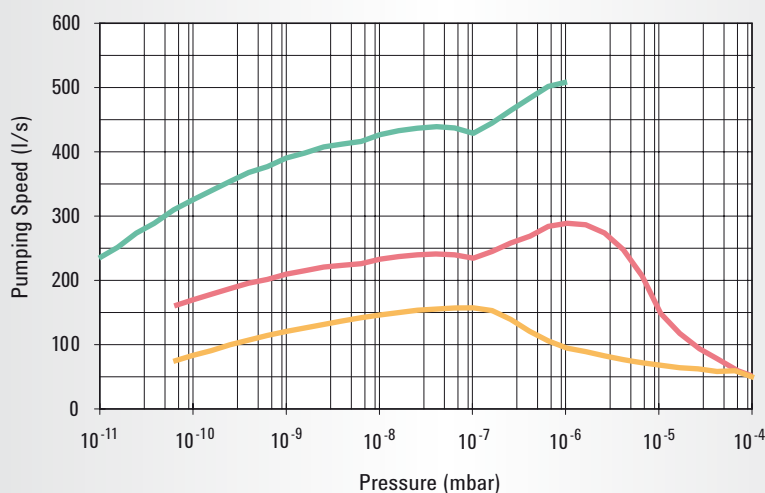

— Nitrogen unsaturated Diode — Nitrogen saturated Diode — Argon saturated StarCell

Ordering Information

Description	Part Number
Pumps	
Diode	9191610
Diode with heaters installed 120 V	9191611
Diode with heaters installed 220 V	9191612
Diode double-ended	9191650
Diode double-ended with heaters installed 120 V	9191651
Diode double-ended with heaters installed 220 V	9191652
StarCell	9191640
StarCell with heaters installed 120 V	9191641
StarCell with heaters installed 220 V	9191642
StarCell double-ended	9191680
StarCell double-ended with heaters installed 120 V	9191681
StarCell double-ended with heaters installed 220 V	9191682
<i>Noble Diode versions available on request</i>	
4UHV Controller	
120 W negative	9299100
120 W positive	9299101
200 W neg	9299010
200 W pos	9299011
2 x 80 W neg	9299200
2 x 80 W pos	9299201
2 x 200 W neg	9299020
2 x 200 W pos	9299021
1 x 200 W pos & 1 x 200 W neg	9299022
4 x 80 W neg	9299400
4 x 80 W pos	9299401
2 x 80 W pos & 2 x 80 W neg	9299402

Description	Part Number
4UHV Controller (cont'd)	
2 x 80 W neg & 1 x 200 W neg	9299210
2 x 80 W pos & 1 x 200 W pos	9299211
2 x 80 W pos & 1 x 200 W neg	9299212
2 x 80 W neg & 1 x 200 W pos	9299213
HV Cables	
HV Bakeable cable, radiation resistant, 4 m (13 ft.) long, with interlock	9290705
HV Bakeable cable, radiation resistant, 7 m (23 ft.) long, with interlock	9290707
HV Bakeable cable, radiation resistant, 10 m (33 ft.) long, with interlock	9290708
HV Bakeable cable, radiation resistant, 20 m (66 ft.) long, with interlock	9290709
Replacement Parts	
HV Feedthrough with interlock	9595125
Pumping element* Diode	9199040
Pumping element* Noble Diode	9199045
Pumping element* StarCell	9199030
Heaters** (Input Power 580 W) 120 V	9190075
Heaters** (Input Power 580 W) 220 V	9190074

* Quantity required: 4.

** To order heaters for replacement or upgrading of existing pumps, please contact your local Agilent Vacuum Technologies representative.

Diode, Noble Diode	positive
StarCell, Triode	negative
(see page 42)	

AGILENT ION PUMP MODELS

▶ Agilent Vaclon Plus 500

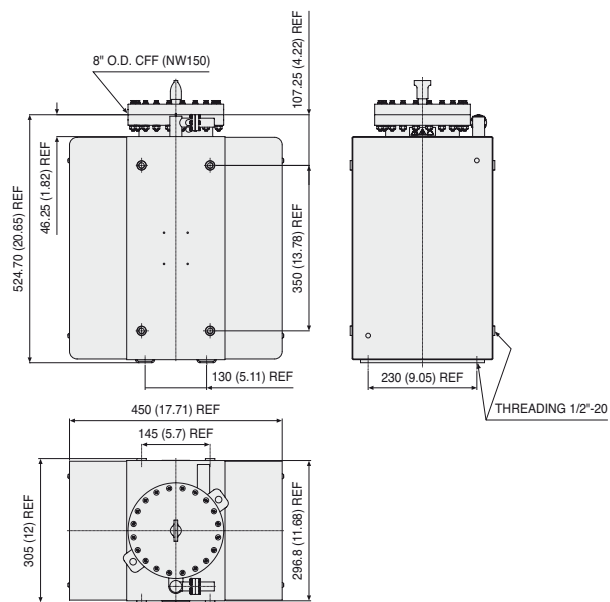

Dimensions: millimeters (inches)

Technical Specifications

	StarCell	Noble Diode	Diode
Nominal pumping speed for Nitrogen (*) (l/s)	410	440	500
Operating life at 1×10^{-6} mbar (hours)	80,000	50,000	50,000
Maximum starting pressure (mbar)	$\leq 5 \times 10^{-2}$	$\leq 1 \times 10^{-3}$	1×10^{-3}
Ultimate pressure	Below 10^{-11}		
Inlet flange	8" CFF (NW 150) AISI 304 ESR		
Maximum baking temperature (°C)	350		
Weight, kg (lbs)	120 (264)		

(*) Tested according to ISO/DIS 3556-1-1992

Vaclon Plus 500 - Pumping Speed vs Pressure

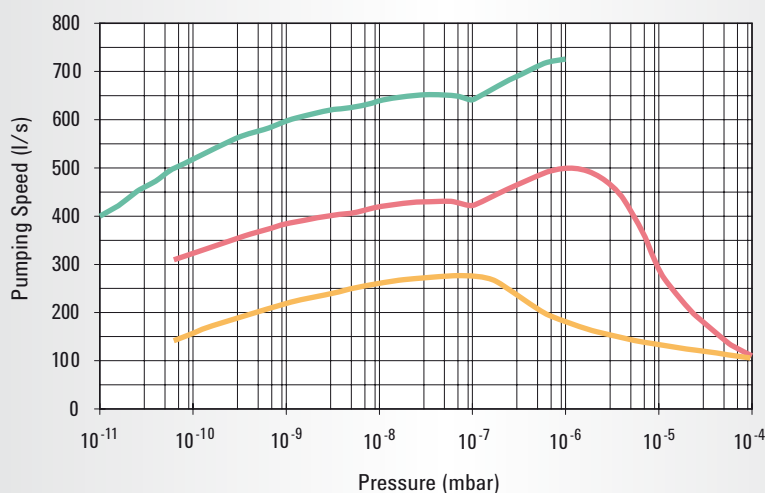

— Nitrogen unsaturated Diode — Nitrogen saturated Diode — Argon saturated StarCell

Ordering Information

Description	Part Number
Pumps	
Diode	9191710
Diode with heaters installed 120 V	9191711
Diode with heaters installed 220 V	9191712
Diode double-ended	9191750
Diode double-ended with heaters installed 120 V	9191751
Diode double-ended with heaters installed 220 V	9191752
StarCell	9191740
StarCell with heaters installed 120 V	9191741
StarCell with heaters installed 220 V	9191742
StarCell double-ended	9191780
StarCell double-ended with heaters installed 120 V	9191781
StarCell double-ended with heaters installed 220 V	9191782
<i>Noble Diode versions available on request</i>	
4UHV Controller	
120 W negative	9299100
120 W positive	9299101
200 W neg	9299010
200 W pos	9299011
2 x 80 W neg	9299200
2 x 80 W pos	9299201
2 x 200 W neg	9299020
2 x 200 W pos	9299021
1 x 200 W pos & 1 x 200 W neg	9299022
4 x 80 W neg	9299400
4 x 80 W pos	9299401
2 x 80 W pos & 2 x 80 W neg	9299402

Description	Part Number
4UHV Controller (cont'd)	
2 x 80 W neg & 1 x 200 W neg	9299210
2 x 80 W pos & 1 x 200 W pos	9299211
2 x 80 W pos & 1 x 200 W neg	9299212
2 x 80 W neg & 1 x 200 W pos	9299213
HV Cables	
HV Bakeable cable, radiation resistant, 4 m (13 ft.) long, with interlock	9290705
HV Bakeable cable, radiation resistant, 7 m (23 ft.) long, with interlock	9290707
HV Bakeable cable, radiation resistant, 10 m (33 ft.) long, with interlock	9290708
HV Bakeable cable, radiation resistant, 20 m (66 ft.) long, with interlock	9290709
Replacement Parts	
HV Feedthrough with interlock	9595125
Pumping element* Diode	9199040
Pumping element* Noble Diode	9199045
Pumping element* StarCell	9199030
Heaters** (Input Power 780 W) 120 V	9190077
Heaters** (Input Power 780 W) 220 V	9190076

* Quantity required: 8.

** To order heaters for replacement or upgrading of existing pumps, please contact your local Agilent Vacuum Technologies representative.

Diode, Noble Diode	positive
StarCell, Triode	negative
(see page 42)	

AGILENT ION PUMP MODELS

▶ Agilent Vaclon *Plus* Large Size Pumps



Agilent Vaclon *Plus* 2500 I/s

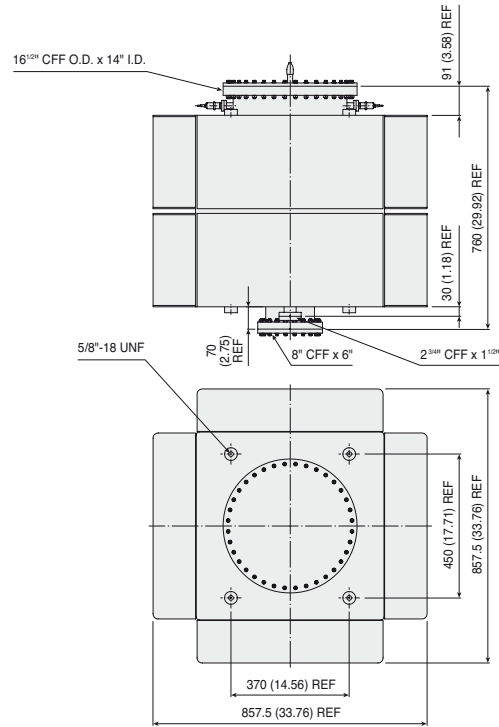

Larger Ion Pumps up to 2500 I/s, in StarCell and Diode versions, are available on request. Please contact Agilent for technical specifications and ordering information.

Agilent Vaclon *Plus* 960 I/s

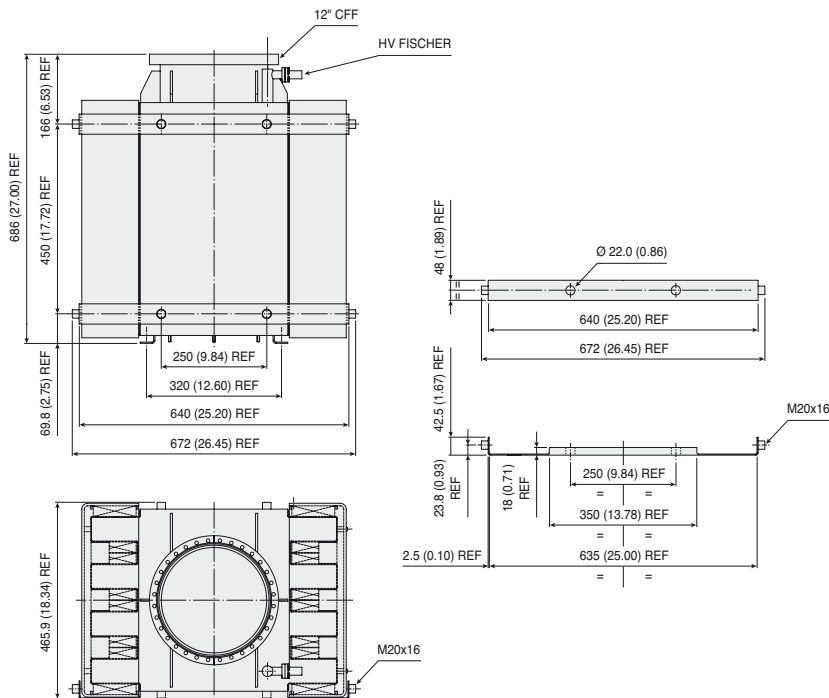

Dimensions: millimeters (inches)

▶ Agilent Vaclon *Plus* Combination Pumps



Titanium Sublimation Combination Pumps

- Ion-Sublimation combination pumps have been a popular choice for many years for creating ultra high vacuum environments. The titanium sublimation creates extra high getterable gas pumping speed while the ion pumping mechanisms handle the non-getterable gases such as argon and methane.
- This combination pump is a Vaclon *Plus* 150, 300, or 500 with an extra side or bottom-mounted 8" ConFlat port. The combination pump includes the cylindrical cryopanel and TSP source mounted to the extra port. Getterable gases enter the end of the cylindrical cryopanel and are pumped by being combined with the freshly-deposited titanium there. Liquid nitrogen cooling the cryopanel increases the efficiency of the gettinger process and adds greatly to the water pumping speed.
- The Agilent Vaclon *Plus* series combination pumps allow addition of a cryopanel from the bottom of the pump or from the side. This can be a significant advantage in situations where height restrictions are present. Customized pump configurations are also available.

Technical Specifications

Nominal net pumping speed at 20 °C (l/s) with StarCell elements (water cooled cryopanel)

Vaclon <i>Plus</i> 150	N ₂ – 610 H ₂ – 1,380
Vaclon <i>Plus</i> 300	N ₂ – 720 H ₂ – 1,580
Vaclon <i>Plus</i> 500	N ₂ – 880 H ₂ – 1,930

Vaclon *Plus* 150 Combination Pump (side-mounted TSP)

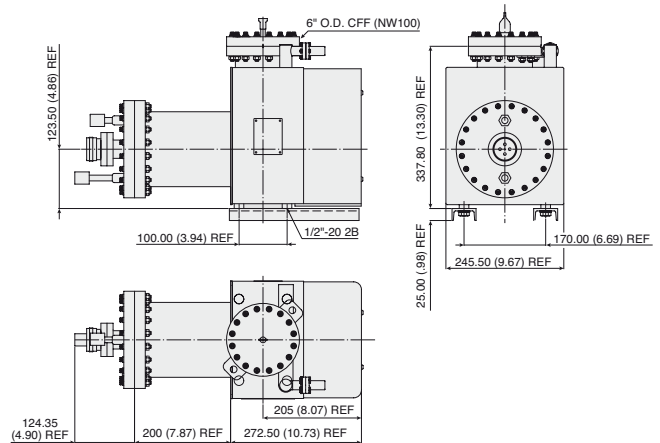

Vaclon *Plus* 300 Combination Pump (side-mounted TSP)

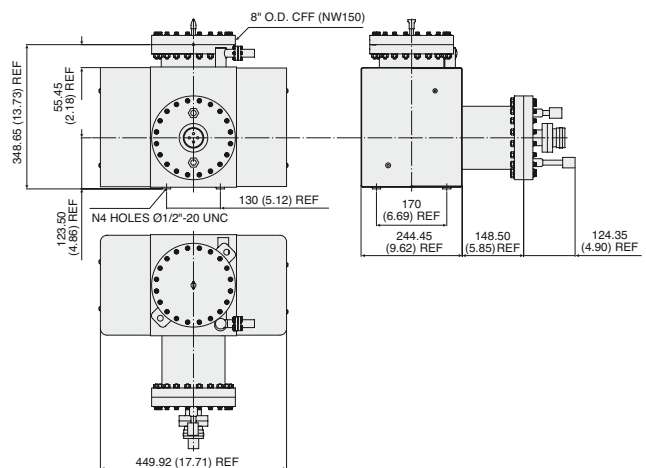

Vaclon *Plus* 500 Combination Pump (side-mounted TSP)

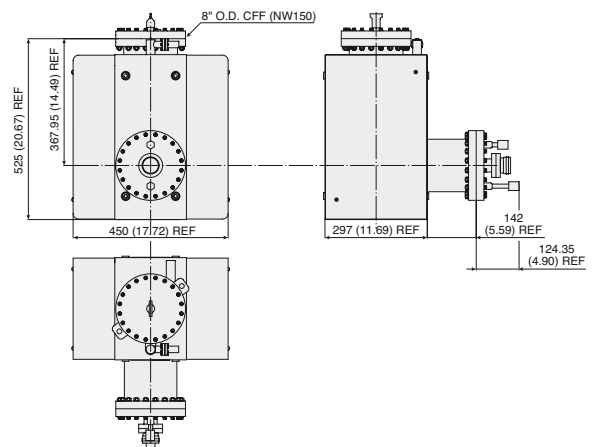

AGILENT ION PUMP MODELS

▶ Agilent Vaclon Plus Combination Pumps

Vaclon Plus 300 Combination Pump (bottom-mounted TSP)

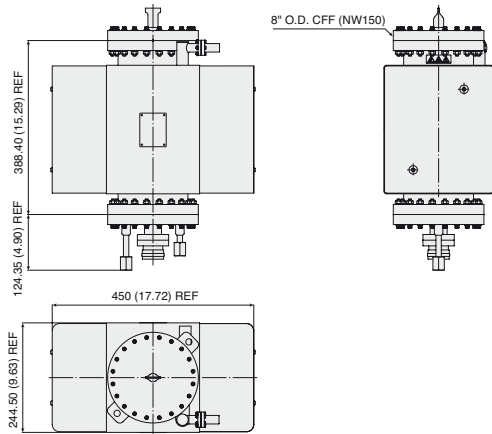

Vaclon Plus 500 Combination Pump (bottom-mounted TSP)

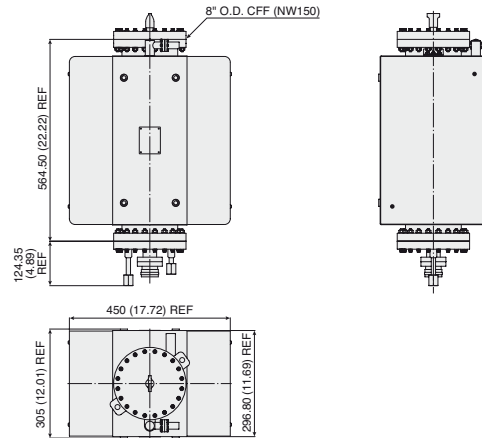

Combination Pumps Pumping Speed

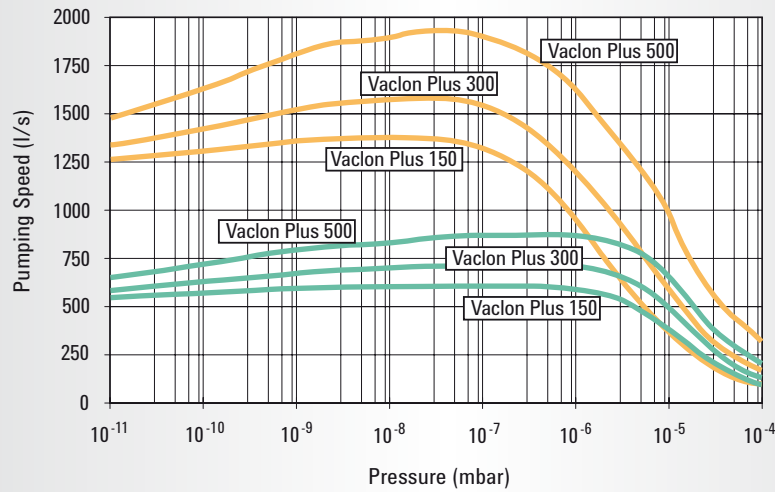

— Nitrogen StarCell — Hydrogen StarCell

Ordering Information

The Vaclon *Plus* 500, 300, and 150 pumps can be supplied with the sublimation cryopanel factory-installed and TSP cartridge included. Cables and controllers are to be ordered separately. For basic pump part number, see pages 22 - 27.

Description		Part Number
Vaclon <i>Plus</i> 500, 300, or 150 combination pump		
Vaclon <i>Plus</i> 150 Diode, with Side-Mounted Cryopanel, with TSP Cartridge and with Installed Heater	120V	9192510
Vaclon <i>Plus</i> 150 Diode, with Side-Mounted Cryopanel, with TSP Cartridge and with Installed Heater	220V	9192511
Vaclon <i>Plus</i> 150 Noble Diode, with Side-Mounted Cryopanel, with TSP Cartridge and with Installed Heater	120V	9192520
Vaclon <i>Plus</i> 150 Noble Diode, with Side-Mounted Cryopanel, with TSP Cartridge and with Installed Heater	220V	9192521
Vaclon <i>Plus</i> 150 Starcell, with Side-Mounted Cryopanel, with TSP Cartridge and with Installed Heater	120V	9192540
Vaclon <i>Plus</i> 150 Starcell, with Side-Mounted Cryopanel, with TSP Cartridge and with Installed Heater	220V	9192541
Vaclon <i>Plus</i> 300 Diode, with Side-Mounted Cryopanel, with TSP Cartridge and with Installed Heater	120V	9192610
Vaclon <i>Plus</i> 300 Diode, with Side-Mounted Cryopanel, with TSP Cartridge and with Installed Heater	220V	9192611
Vaclon <i>Plus</i> 300 Noble Diode, with Side-Mounted Cryopanel, with TSP Cartridge and with Installed Heater	120V	9192620
Vaclon <i>Plus</i> 300 Noble Diode, with Side-Mounted Cryopanel, with TSP Cartridge and with Installed Heater	220V	9192621
Vaclon <i>Plus</i> 300 Starcell, with Side-Mounted Cryopanel, with TSP Cartridge and with Installed Heater	120V	9192640
Vaclon <i>Plus</i> 300 Starcell, with Side-Mounted Cryopanel, with TSP Cartridge and with Installed Heater	220V	9192641
Vaclon <i>Plus</i> 300 Diode, with Bottom-Mounted Cryopanel, with TSP Cartridge and with Installed Heater	120V	9192612
Vaclon <i>Plus</i> 300 Diode, with Bottom-Mounted Cryopanel, with TSP Cartridge and with Installed Heater	220V	9192613
Vaclon <i>Plus</i> 300 Noble Diode, with Bottom-Mounted Cryopanel, with TSP Cartridge and with Installed Heater	120V	9192622
Vaclon <i>Plus</i> 300 Noble Diode, with Bottom-Mounted Cryopanel, with TSP Cartridge and with Installed Heater	220V	9192623
Vaclon <i>Plus</i> 300 Starcell, with Bottom-Mounted Cryopanel, with TSP Cartridge and with Installed Heater	120V	9192642
Vaclon <i>Plus</i> 300 Starcell, with Bottom-Mounted Cryopanel, with TSP Cartridge and with Installed Heater	220V	9192643
Vaclon <i>Plus</i> 500 Diode, with Side-Mounted Cryopanel, with TSP Cartridge and with Installed Heater	120V	9192710
Vaclon <i>Plus</i> 500 Diode, with Side-Mounted Cryopanel, with TSP Cartridge and with Installed Heater	220V	9192711
Vaclon <i>Plus</i> 500 Noble Diode, with Side-Mounted Cryopanel, with TSP Cartridge and with Installed Heater	120V	9192720
Vaclon <i>Plus</i> 500 Noble Diode, with Side-Mounted Cryopanel, with TSP Cartridge and with Installed Heater	220V	9192721
Vaclon <i>Plus</i> 500 Starcell, with Side-Mounted Cryopanel, with TSP Cartridge and with Installed Heater	120V	9192740
Vaclon <i>Plus</i> 500 Starcell, with Side-Mounted Cryopanel, with TSP Cartridge and with Installed Heater	220V	9192741
Vaclon <i>Plus</i> 500 Diode, with Bottom-Mounted Cryopanel, with TSP Cartridge and with Installed Heater	120V	9192712
Vaclon <i>Plus</i> 500 Diode, with Bottom-Mounted Cryopanel, with TSP Cartridge and with Installed Heater	220V	9192713
Vaclon <i>Plus</i> 500 Noble Diode, with Bottom-Mounted Cryopanel, with TSP Cartridge and with Installed Heater	120V	9192722
Vaclon <i>Plus</i> 500 Noble Diode, with Bottom-Mounted Cryopanel, with TSP Cartridge and with Installed Heater	220V	9192723
Vaclon <i>Plus</i> 500 Starcell, with Bottom-Mounted Cryopanel, with TSP Cartridge and with Installed Heater	120V	9192742
Vaclon <i>Plus</i> 500 Starcell, with Bottom-Mounted Cryopanel, with TSP Cartridge and with Installed Heater	220V	9192743

Description		Weight kg (lbs)	Part Number
Replacement Parts and Accessories			
TSP Filament Cartridge on 2 3/4" CFF		2.7 (6.0)	9160050
Replacement filaments, package of 12 each		0.4 (2.0)	9160051
Titanium Sublimation Pump Control Unit (Order cables separately)	120V	17.7 (39.0)	9290022
Titanium Sublimation Pump Control Unit (Order cables separately)	220V	17.7 (39.0)	9290023
TSP Cartridge cable, 3.5 m (12 ft.)		9.1 (20.0)	9240730
Sublimation Cryopanel on 8" CFF		10.5 (23.0)	9190180

AGILENT ION PUMP CONTROLLERS

▶ Agilent Mini Vac Controller

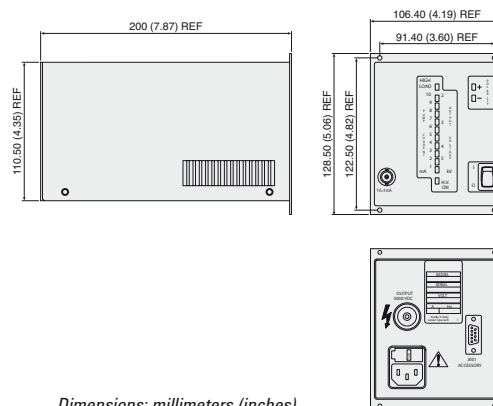

The MiniVac Ion Pump Controller is designed to economically operate any Vaclon Plus type and size: Diode, Noble Diode, and StarCell, from Miniature to 500 l/s pumps. The MiniVac is very compact and light, can be operated in local or remote mode, and is suitable for high radiation environments.

Medium pumps (Vaclon Plus 20 to 75) can be operated at any pressure below 1×10^{-5} mbar (continuous operation).

Large pumps (Vaclon Plus 150 to 500) can be operated at any pressure below 2×10^{-6} mbar (continuous operation).

The MiniVac is designed to withstand continuous operation at short circuit conditions, without damaging the ion pump or itself. A 24 V battery-operable version is available for portable applications.

Technical Specifications

Input

90 to 130 VAC or 180 to 240 VAC or 24 VDC

Output

Voltage: ± 5000 VDC (open load) (factory pre-set is negative)

Current: 15 mA (short circuit)

Maximum Power: 21 W (3 kV at 7 mA)

Front Panel

HV ON, HIGH LOAD, and POLARITY LEDs

LED bargraph linear scale for current and voltage indication

Recorder Output 0 to +10 VDC linear proportional to current (10 V = 10 mA)

Safety Marks

CE

Conformity to Norms

Safety: EN61010-1

EMI/EMC: EN61000-4-2, EN61000-4-3, EN61000-4-4

Rear Panel

Nine pin "D" type connector with following available signals and commands Recorder outputs:

- 0 to +5 VDC, linear proportional to HV (1 V = 1 kV)
- 0 to +10 VDC, linear proportional to current (10 V = 10 mA)
- 0 to +10 VDC, linear proportional to current (10 V = 1 mA)

HV ON confirm signal: Contact rating – 1 A at 250 VAC; 0.2 A at 30 VDC

Remote HV ON/OFF (interlock) command

HV connector: Fischer type 105 or King type, 10 kV

ION PUMPS

Ordering Information

Description		Weight kg (lbs)	Part Number
MiniVac Controller			
With any Vaclon Plus pump	MiniVac, FISCHER HV connector, US plug, 120 V preset	2.3 (5.0)	9290191
	MiniVac, FISCHER HV connector, European plug, 220 V preset	2.3 (5.0)	9290290
	MiniVac, FISCHER HV connector, 24 VDC	2.3 (5.0)	9290196
With small Vaclon pumps (2 and 10 l/s)	MiniVac, KING HV connector, US plug, 120 V preset	2.3 (5.0)	9290190
	MiniVac, KING HV connector, European plug, 220 V preset	2.3 (5.0)	9290291
	MiniVac, KING HV connector, 24 VDC	2.3 (5.0)	9290197
Accessories and Cables			
	19" Rack adapter	4.5 (10.0)	9699191
With any Vaclon Plus pump	HV bakeable cable, radiation resistant, 4 m (13 ft.) long, with Interlock	0.9 (2.0)	9290705
	HV bakeable cable, radiation resistant, 7 m (23 ft.) long, with Interlock	1.6 (3.5)	9290707
	HV bakeable cable, radiation resistant, 10 m (33 ft.) long, with Interlock	2.2 (5.0)	9290708
	HV bakeable cable, radiation resistant, 20 m (66 ft.) long, with Interlock	4.4 (10.0)	9290709
With small Vaclon pumps (2 and 10 l/s)	HV bakeable cable, radiation resistant, 4 m (13 ft.) long, with Interlock for 2 l/s pump	0.9 (2.0)	9290706
	HV cable, 3 m (10 ft.) long, for 8 l/s Vaclon pumps	0.9 (2.0)	9240741

Diode, Noble Diode	positive
StarCell, Triode (see page 42)	negative

AGILENT ION PUMP CONTROLLERS

▶ Agilent 4UHV Ion Pump Controller



How much power do I need for my ion pumps?

Power requirement depends on the pump size and starting pressure; the larger the pump and higher the starting pressure, the higher the power consumption.

The largest standard Ion Pump configuration, 500 l/s, can be easily started with 200W up to 10^{-5} mbar, while a medium size pump (75 l/s) needs less than 80 W to be started at the same pressure, and 80 W are sufficient to operate a 500 l/s in the typical Ion Pump operating range (below 2×10^{-6} mbar).

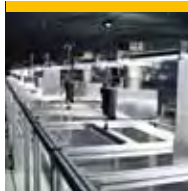

Why was the higher power rating necessary in the past?

In the past ion pumps were started with the aid of sorption pumps, able to reach 10^{-4} mbar only. As a consequence, much larger and more powerful Ion pumps controller were needed. The resulting life of Ion Pumps started at such high pressures was much shorter (1 minute of operation at 10^{-4} mbar is equivalent to 2 months at 10^{-9} mbar). Today's oil-free turbo pumps, backed by oil-free primary pumps, achieve lower pressures, thereby reducing the starting pressure of the ion pump. This reduces the maximum power requirement of the ion pump controller and extends the lifetime of the ion pump.



Negative or positive?

The requirement of negative or positive potential depends on the pumping element installed in the ion pump. Diode style elements (Diode & Noble Diode) need positive voltages, while Triode style elements (old style Triode & StarCell) need negative voltages for operation.

ION PUMPS

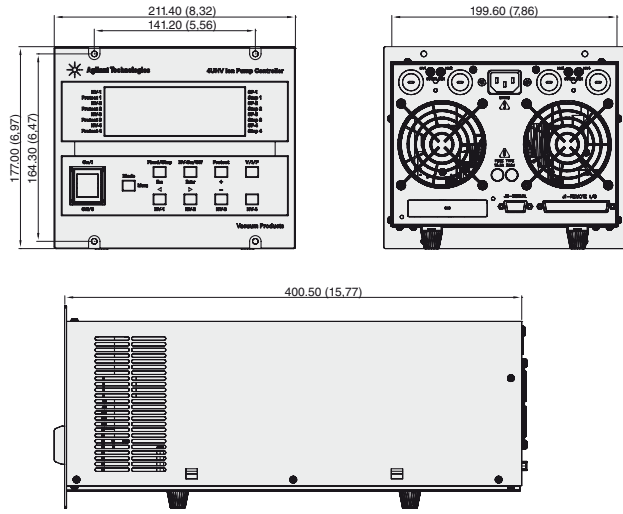

Technical Specifications

Input voltage	100 - 240 Vac (+/-10%)
Input frequency	50/60 Hz
Dimensions	400.5 x 211.4 x 177.0 mm (l x w x h)
Display	4 rows with 20 characters
Available configurations	1 x 120 W, 1 x 200 W, 2 x 80 W, 2 x 200 W, 4 x 80 W, 2 x 80 W + 1 x 200 W
Minimum configuration	One HV card with 120 W, 200 W or 2x80 W
Output voltage (Open Circuit)	3.5 and 7 kV
Output current (Short Circuit)	40 mA for 80 W channel, 100 mA for 200 W channel

Modes of operation	Local / Serial / Remote
Front panel readings	Voltage, Pressure, Current, Status
Safety marks	CE, C_GSA_US
Current measurement range	10 nA to 100 mA
Input signals	On/off; Protect; Step Mode;
Output signals	Analog Out; NC Set-point; NO Set-point
HV connector	Fischer Type 105
Output Power Maximum	400 W
Communications	RS232/485 standard Profibus or Ethernet optional

Ordering Information

Description	Part Number
4UHV Controller	
120 W negative	9299100
120 W positive	9299101
200 W neg	9299010
200 W pos	9299011
2 x 80 W neg	9299200
2 x 80 W pos	9299201
2 x 200 W neg	9299020
2 x 200 W pos	9299021
1 x 200 W pos & 1 x 200 W neg	9299022
4 x 80 W neg	9299400
4 x 80 W pos	9299401
2 x 80 W pos & 2 x 80 W neg	9299402
2 x 80 W neg & 1 x 200 W neg	9299210
2 x 80 W pos & 1 x 200 W pos	9299211
2 x 80 W pos & 1 x 200 W neg	9299212
2 x 80 W neg & 1 x 200 W pos	9299213

Description	Part Number
Accessories and Cables *	
HV Bakeable cable, radiation resistant, 4 m (13 ft.) long, with interlock	9290705
HV Bakeable cable, radiation resistant, 7 m (23 ft.) long, with interlock	9290707
HV Bakeable cable, radiation resistant, 10 m (33 ft.) long, with interlock	9290708
HV Bakeable cable, radiation resistant, 20 m (66 ft.) long, with interlock	9290709
Rack adapter 19"	9290064
Mains cable NEMA Plug, 3 m (10 ft.) long	9699958
Mains cable European Plug, 3 m (10 ft.) long	9699957

(*) The unit does not include the power cable, please order the cable separately.

Ion Pumps

AGILENT ION PUMP MODELS

▶ Agilent Miniature and Small Vaclon Pumps and Controllers

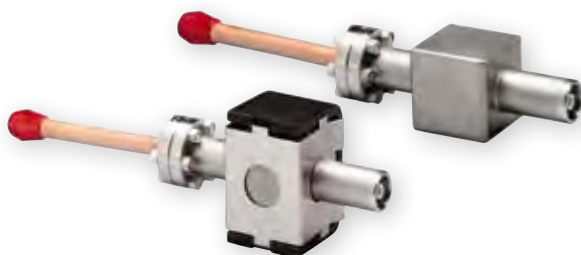

Agilent offers a wide variety of small size ion pumps designed especially for electron device and detector applications. The Miniature Vaclon pump is a diode configuration and provides approximately 0.4 l/s of nitrogen pumping speed. The 2 l/s model is a modified diode configuration to enhance starting at low pressure. The 10 l/s pump is a noble gas optimized diode configuration with high efficiency for residual gases such as hydrogen. The pumping speed for noble gases is about 20% of the nominal speed.

Pumps that are processed are baked to 400 °C and pinched

off under vacuum, which allows the vacuum integrity to be verified by the user just before use. Non-processed pumps are tested for no vacuum leaks and minimum leakage current.

Modified and Customized Versions

Modified versions of standard pumps can be provided when different inlet tube lengths, angles, and diameters are required. These pumps can also be customized with different high voltage feedthroughs, body geometries, and pumping cell arrangements. Special testing procedures can be quoted for customers who have specific requirements in this area.

Ordering Information

See pages 32 - 33 for controllers, cables, and accessories.

Description	Weight kg (lbs)	Part Number
Miniature Pump		
With 3/8" OD 180° stainless steel tube	0.5 (1.0)	9130038
With 3/8" OD 90° stainless steel tube	0.5 (1.0)	9130041
With 3/8" OD 180° copper tube, vacuum processed	0.5 (1.0)	9130049
With 3/8" OD 90° copper tube, vacuum processed	0.5 (1.0)	9130050
Magnet for Miniature pump	0.5 (1.0)	9130042
HV cable, 2.4 m (8 ft.) long, for Mini Vaclon pumps	0.9 (2.0)	9240122
2 l/s Pump		
With 3/4" OD 180° stainless steel tube	0.9 (2.0)	9190521
With 3/4" OD 180° copper tube, vacuum processed	0.9 (2.0)	9190522
With 3/4" OD 180° stainless steel tube, vacuum processed	0.9 (2.0)	9190523
With 3/4" OD 90° stainless steel tube, tee style	0.9 (2.0)	9190524
With 1 1/3" CFF 180° vacuum processed	0.9 (2.0)	9190520
Magnet for 2 l/s pump	0.9 (2.0)	9190038
HV bakeable cable, radiation resistant, 4 m (13 ft.) long with interlock for 2 l/s pump	0.9 (2.0)	9290706
10 l/s Pump		
10 l/s Vaclon pump, processed, with 2 3/4" CFF	3.6 (8.0)	9195005
Magnet assembly for 10 l/s Vaclon pump	5.0 (11.0)	9110030
HV cable, 3 m (10 ft.) long, for 10 l/s Vaclon pumps	0.9 (2.0)	9240741

Magnets must be ordered separately.

ION PUMPS

Miniature Pump (90 deg. config.)

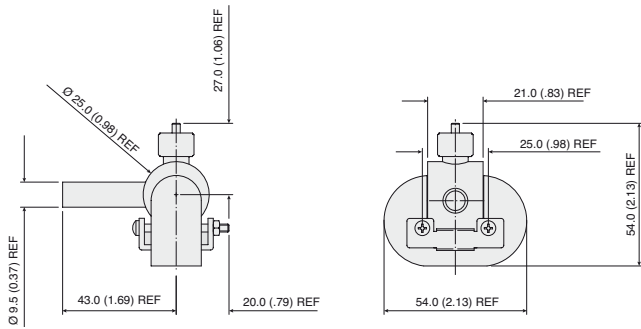

Miniature Pump (180 deg. config.)

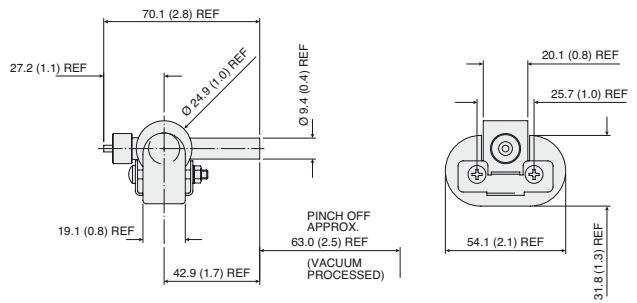

2 l/s Pump

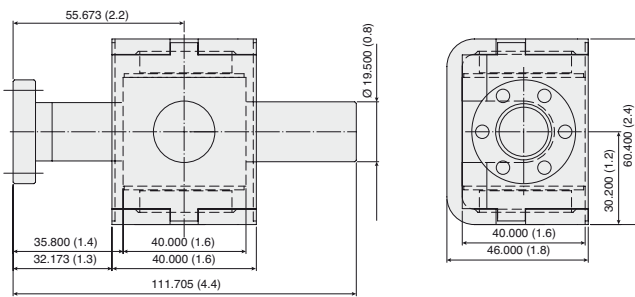

10 l/s Pump

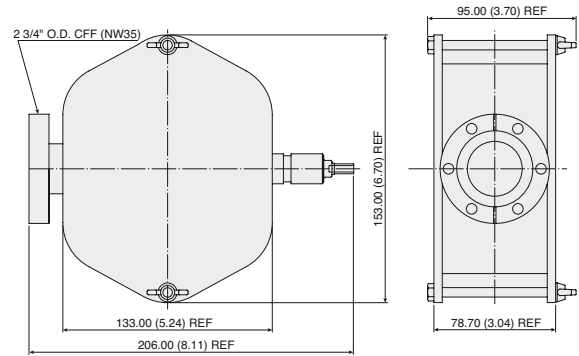

Dimensions: millimeters (inches)

The Miniature and 2 l/s pumps are available with copper or stainless steel inlet tubes in 90- or 180-degree configurations, relative to the high voltage feedthrough.

Ion Pumps

AGILENT TITANIUM SUBLIMATION PUMPS AND CONTROLLERS

► TSP Cartridge

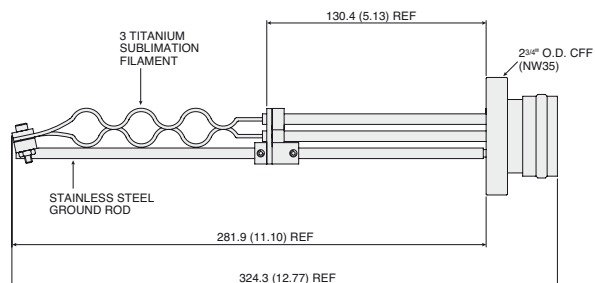

Dimensions: millimeters (inches)

Titanium sublimation pumps (TSPs) are typically used as an effective way to pump getterable gases such as hydrogen and nitrogen in UHV systems. TSPs are often combined with ion pumping, since the ion pump is effective with non-getterable UHV gases such as argon and methane. The TSP can be added to the inside of the ion pump, or as a separate pumping unit. If the TSP is used in conjunction with a liquid nitrogen-cooled cryopanel, extra high water pumping speed will be achieved.

Agilent offers two different types of titanium sublimation pumps: filament and titanium ball sources. Filament-type TSP sources are most popular with UHV systems since they can be turned off between sublimations and thus do not add thermally-induced outgassing. The ball-type sources contain larger amounts of titanium which means longer life when operated under conditions that use more titanium, such as higher operating pressures. However, the ball sources require standby power between sublimations to prevent cracks from forming in the titanium ball.

The factors affecting titanium sublimation pumping efficiency include sublimation rate, frequency, surface area, and temperature. Sublimation pumping speed is generally a constant value below 10^{-7} mbar.

TSP Cartridge Filament Source

The popular TSP cartridge is provided on a 2 3/4" OD ConFlat flange and contains three titanium-molybdenum filaments, each with 1.1 grams of usable titanium. The cartridge assembly is bakeable to 400 °C. Maximum sublimation is achieved at 300 watts of source power.

Technical Specifications

Usable titanium (per filament)	1.1 grams
Total usable	3.3 grams
Operating range	10^{-4} to 10^{-12} mbar

► Mini Ti-Ball

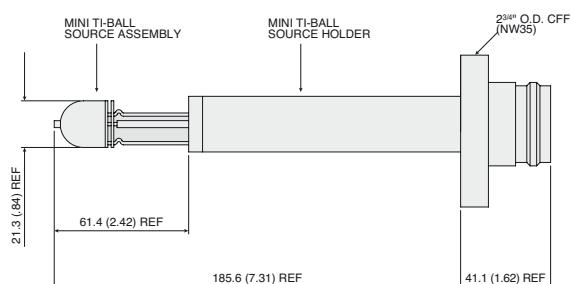

Dimensions: millimeters (inches)

Mini Ti-Ball Source

The Mini Ti-Ball source provides 15.2 grams of usable titanium and is mounted on a 2 3/4" OD ConFlat flange. Maximum sublimation is achieved at 300 watts of source power, while the Standby power requirement is 100 watts.

Technical Specifications

Usable titanium	15.2 grams
Operating range	10^{-4} to 10^{-12} mbar

▶ Agilent TSP Cryopanel

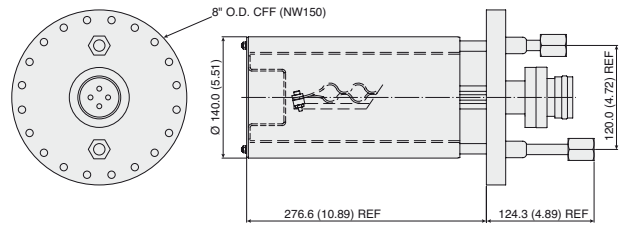

Dimensions: millimeters (inches)

TSP Cryopanel

Designed for use with the TSP cartridge source*, this sublimation cryopanel is mounted to an 8" OD ConFlat flange. It can operate with water cooling, liquid nitrogen, or uncooled if used at UHV. This cryopanel can be mounted to double-ended or side-ported ion pumps and can also be used independently in any 8" (NW 150) CFF port with 11 inch depth/clearance.

The Cryopanel does not include the cartridge.

Technical Specifications

	N ₂	H ₂	H ₂ O
Pumping speed at 20 °C water-cooled (l/s)	515	1200	575
Inner pumping surface (cm²)	826		
Main flange	8" CF (NW150)		
Reservoir volume (liters)	1.8		
Cooling connection	3/8" G		
Titanium source flange	2 3/4" CF		

Pumping Speed vs Pressure at different evaporation rates

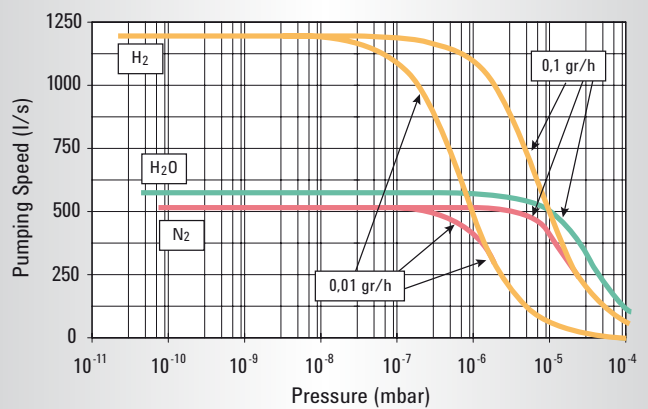

AGILENT TITANIUM SUBLIMATION PUMPS AND CONTROLLERS

▶ Agilent TSP Controller

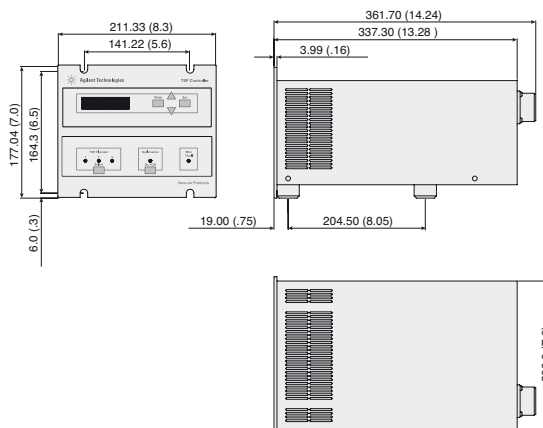

Dimensions: millimeters (inches)

- Pump cable lengths up to 50 m
- Compact design ½ standard rack
- Selectable for automatic or manual operation
- Remote control (standard) via RS232/485

- To operate Agilent TSP filament cartridge or Agilent Mini Ti-Ball
- Safety Marks: CE, cCSAus

Technical Specifications

Input	100, 120, 220, 240 Vac ±10% 1-phase
Voltage (selectable at the rear of the case)	<ul style="list-style-type: none"> • 90 to 110 Vac - 1 phase (use setting 100 Vac) • 110 to 130 Vac - 1 phase (use setting 120 Vac) • 190 to 230 Vac - 1 phase (use setting 220 Vac) • 230 to 265 Vac - 1 phase (use setting 240 Vac)
Frequency	47 to 63 Hz
Power	1400 VA (maximum, see note)
Fuse	<ul style="list-style-type: none"> 2 x T15A (slow blow) 250V 5x20 fuses (only for model 929-0032) 2 x T8A (slow blow) 250V 5x20 fuses (only for model 929-0033)
Temperature	0 to + 45 °C
Humidity	90 % maximum non condensing humidity
Storage temperature	-20 °C to +70 °C

In compliance with norms	EN 61010-1 (2001) EN 61326-1 (2006) - Class A (industrial application)
Protection category	IP 20
Internal use only	
Installation category	II
Pollution degree	2 3 meters long
Power cable	<ul style="list-style-type: none"> • 3 wires Ø AWG14, NEMA plug (only for model 929-0032) • 3 wires Ø 0.75 mm² European plug (only for model 929-0033)
Weight	12 kg (26.5 lbs)

NOTE • When the controller is powered by means of a transformer, the transformer power must be at least 3000 VA to avoid a distortion of the power waveform.

Ordering Information

Titanium Sublimation Pumps	Part Number
TSP Filament Cartridge on a 2 ¾" CFF	9160050
Replacement filaments, package of 12 each	9160051
Mini Ti-Ball Source with Holder on a 2 ¾" CFF	9160009
Replacement Mini Ti-Ball Source	9160008
Titanium Sublimation Cryopanel	Part Number
Sublimation Cryopanel on an 8" CFF	9190180
Controllers	Part Number
Sublimation Controller set for 220 Vac	9290033
Sublimation Controller set for 110 Vac	9290032

Accessories	Part Number
Cable for TSP pump (3.5 mt)	9240730
Cable for TSP pump (7 mt)	9240730M002
Cable for TSP pump (10 mt)	9240730M001
Cable for TSP pump (30 mt)	9240730M017
Cable for TSP pump (40 mt)	9240730M015
Cable for TSP pump (50 mt)	9240730M013
Cable for Mini Ti-Ball pump	9240752
Rack adapters	9290064

Historical Notes

Ion pumping is used to remove gases from systems in order to create ultra-high vacuum environments. The earliest evidence of ion pumping was reported by J. Plucker (1858 - Germany) who found that it took ever-increasing voltages to maintain a current in a gas discharge tube.

This, he rightly concluded, is due to a reduction of pressure in the tube by some mechanism involving the cathode.

Later, as an offshoot of his work on electrical discharge in gases, F. Penning (1937 - Holland) developed a cold cathode ionization gauge for measuring pressures in the range of 10^{-3} to 10^{-5} Torr. Due to the sputtering effect of the high voltage, ions were both buried in and “gettered” by the cathode material. (Gettering is the chemical combination of active gases with a suitably reactive substance).

The result of this pumping action was a noticeable pressure reduction. The Penning cell has been used as a commercially available vacuum gauge ever since, but it was not until the late 1950's that its pumping characteristics were exploited, resulting in the invention of the ion pump. This was done in order to improve the life and performance of microwave tubes by continuous pumping with “appendage” ion pumps.

The invention of the sputter ion pump ushered in the era of ultrahigh vacuum, just in time to make a large contribution to the space age.

The availability of vacuum systems that could routinely achieve pressures in the low 10^{-11} Torr range enhanced R&D efforts. Space hardware and space-compatible materials were tested by simulating many of the conditions they would encounter. Today, ion pumps are used in both research and industrial applications wherever a pristine, oil-free, vibration-free, cost-effective environment is required.

Operation

Vacuum pumps in general operate on the basis of maintaining a lower gas density within themselves than exists in the environment they are pumping. This results in a net gas migration into the pump due to the random motion of the molecules under molecular flow conditions. Once in the pumps, few escape and they are either displaced or captured, depending on the type of pump.

Rather than being a displacement pump that actually moves molecules of gas through it to the atmosphere, the ion pump instead captures and stores them. As a result, at some point in time the pump must be reconditioned or replaced. This is generally required only after many years of use.

The generic name Sputter Ion Pump (or Ion Getter Pump) comes from the fact that some of the gas molecules undergo ionization and cause sputtering of the gettering agent. This material chemically reacts with the active gases to form stable compounds that are deposited on the internal walls of the pump. The getter, usually titanium, is provided by a plate

or electrode of that material, which is in turn sputtered and eroded by gas ions formed under the influence of the high voltage. These electrical potentials are usually in the range of 3,000 to 7,000 Vdc.

Most ionization devices operate in the same way. Gas molecules are bombarded by high energy electrons when a collision occurs. A molecule may lose one or more of its own electrons and thereby is left as a positively charged ion. Under the influence of a strong electric field, the ion is accelerated into the titanium cathode. The force of this collision is sufficient to cause atoms to be ejected from the cathode and “sputtered” onto the adjacent walls of the pump. Freshly sputtered titanium is extremely reactive and will chemically react with active gases. The resulting compounds accumulate on surfaces of the pump elements and pump walls.

Active gases are those such as oxygen, nitrogen, CO, CO₂, and water, as opposed to the noble gases like helium, neon, argon, krypton, and xenon, which are nonreactive. The latter are pumped by “ion burial” (ion burial is the “plastering over” of inert gas atoms by the sputtered getter atoms).

The simplest form of ion pump is the Penning cell, which was originally conceived as a cold cathode vacuum gauge. It consists of a central anode wire which is at positive high voltage. In an ion pump the anode can either be a short section of metal tubing or a square, box-like structure, open at each end like a unit of an egg crate. Opposite each open end is a plate of titanium that is connected to the ground to form the cathode structure. An external permanent magnetic circuit generates a magnetic field, usually ranging from 800 to 2,000 G, parallel to the anode cell axis. A cell configured in this way is said to be a diode pump (Figure 1). It is then packaged in a suitable enclosure and the assembly becomes a pump.

To make a higher speed pump, it is now simply a matter of making a package containing more cells with a larger cathode (Figure 2).

The function of the anode cell structure is to contain a “cloud” of high energy electrons which are constrained by the magnetic field.

This field causes the electrons to move in oscillating spiral paths (Figure 3) that increase their chances of striking gas molecules and thereby create positive ions. These ions are accelerated away from the positive anode voltage and collide into the titanium cathode plates (Figure 3). This results in the removal of titanium atoms by “sputtering”.

The sputtered titanium is deposited on the internal surfaces of the pump where it reacts with absorbed active gases to form stable compounds.

In summary, the pumping efficiency depends on the electron “cloud” density (which determines the number of ions produced) and on the sputtering yield (which determines the quantity of active getter material produced).

The electron cloud density mainly depends on the Penning

AGILENT ION PUMP TECHNICAL NOTES

Figure 1

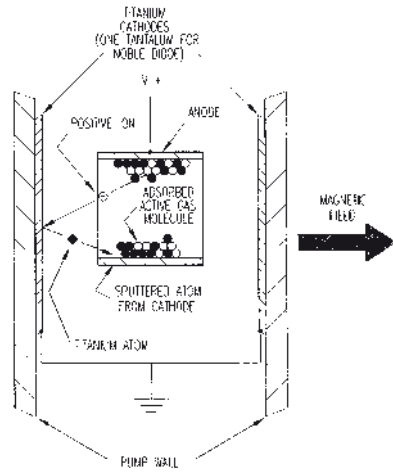

Ion pump cutaway



Figure 2

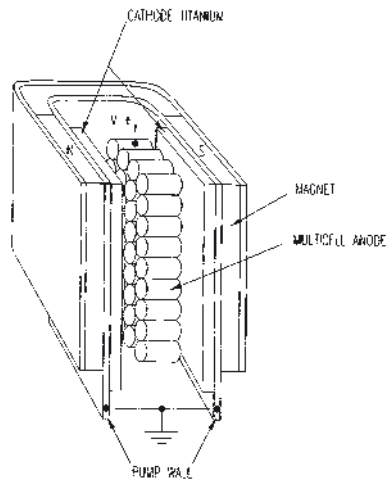

Figure 4

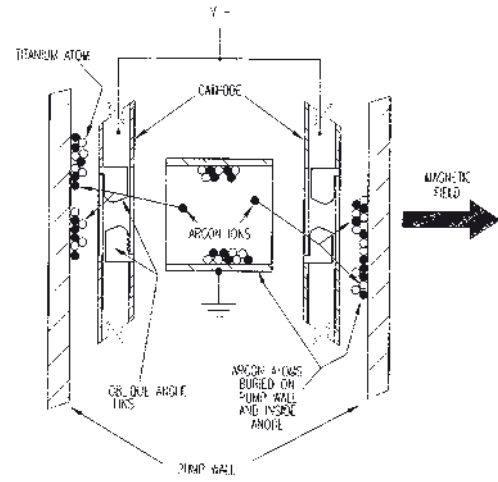

Figure 3

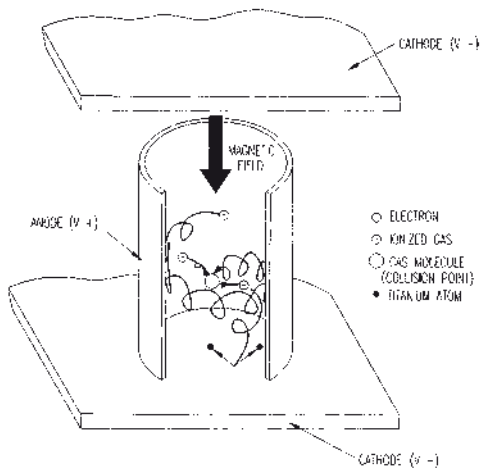
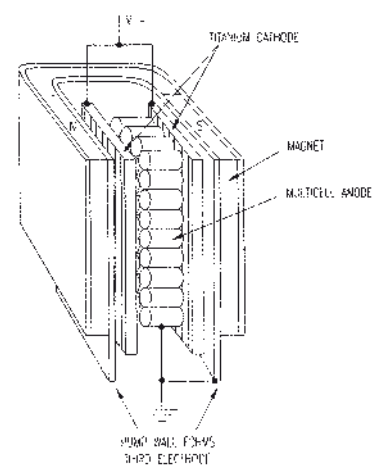

Figure 5



cell geometry and on the electric and magnetic field strengths. By adjusting these parameters, the pump performance can be modified according to the application. In particular, using an “intelligent” high voltage power supply, the right voltage can be automatically selected as the pressure changes.

The sputtering efficiency depends on the cathode geometry and material and on the gas species. Thus the cathode configuration can also be optimized for the gas used in the application.

Agilent offers three different cathode configurations that will satisfy a wide variety of applications involving different gases and operative pressures.

It should be noted that a few types of gases do not need to be ionized in order to be pumped. Hydrogen, for instance, forms a solid solution directly with the titanium cathode plates as well as the sputtered film.

It is the function of the ions to maintain a fresh supply of “gettering” material. In this regard, the ion pump is self-regulating; it only sputters as much getter material as is needed at that particular pressure.

In this way, at low pressures cathode plates are not wasted and electric power is conserved.

Some of the noble gas atoms are pumped as a result of being ionized.

In this case, they are implanted (at least temporarily) in the cathodes by the force of the accelerating voltage. Others are pumped by burial in the sputtered titanium film (Figure 4). Generally, pumping noble gases does not pose a problem because they are present in such small quantities. When it is necessary to deal with considerable amounts of noble gases, a pump of the triode configuration should be used (Figure 5). In the triode pump, the cathode is at negative potential and built with slits that permit grazing incidence sputtering. Thus, they tend not to be implanted to any appreciable extent and the un-sputtering of previously buried noble gases is largely eliminated. Instead, the gases either react with or are buried by the sputtered film on the walls of the pump body and on the anode.

Selecting Vaclon Plus Pumps

Ion pumps are commonly used to create Ultra High Vacuum (UHV), due to their cleanliness, ability to pump different gases, and maintenance- and vibration-free operation. Long operating life and ability to read pressure are other important features of ion pumps.

The Vaclon Plus family has been designed to enhance all of these characteristics, and thus offers the most advanced and valuable solution to any ion pumping requirement.

Cleanliness

To reach very low pressures (i.e. 10^{-11} mbar) in any system, both the chamber and pump outgassing must be minimized.

If not cleaned properly, the ion pump itself can be a source of gas at UHV.

In order to ensure cleanliness, Vaclon Plus Pumps are factory processed at high temperature in ultraclean vacuum for a thorough outgassing of the body and all internal components. The cleanliness of the ion pump element at high temperature (450 °C) in ultraclean is even more critical, due to the continuous cathode bombardment. Any gas trapped on the surface or in the bulk of the cathode will eventually be released.

Ion Pump Outgassing System

The ion pump outgassing system is a thermal process of the pump, completely computer controlled and able to provide an automatic final test of the achieved pump specifications.

The bake-out of the pump is done in a nitrogen-controlled atmosphere to protect the external pump body from oxidation. See Figure 6 for System outline.

Figure 6 - System outline

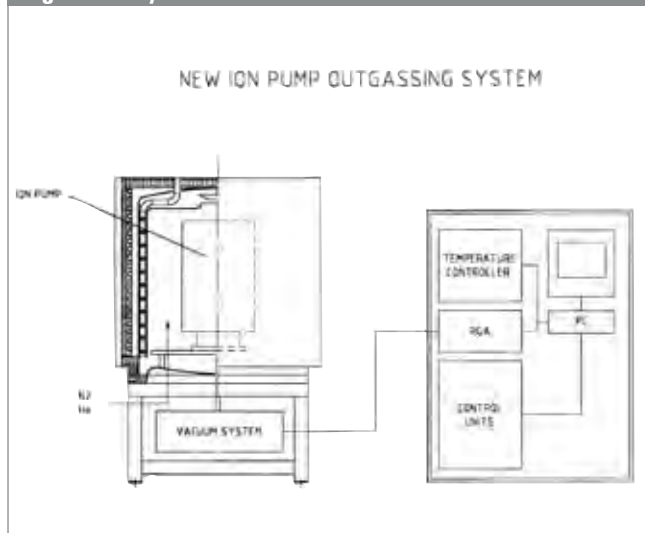

The system is based on the principle of thermal outgassing the ion pump internal surfaces through the control of their intrinsic outgassing. Therefore pressure, not time, is the driving factor of the overall process.

The bake-out time depends on the internal cleaning of the pump components and all the pumps will have, in this way, the same final outgassing rate and base pressure.

Figure 7 shows the working principle. The green curve represents the temperature and the yellow one the pressure read by the gauge located on the vacuum control system placed on the bottom of the outgassing station (see Fig. 6).

The temperature is maintained at the set point level until the pressure does not change any more, which means the outgassing of the pump for the defined bake-out temperature is completed.

At the end of the thermal process, once room temperature is achieved, an RGA is performed.

AGILENT ION PUMP TECHNICAL NOTES

Figure 7 - Thermal process working principle

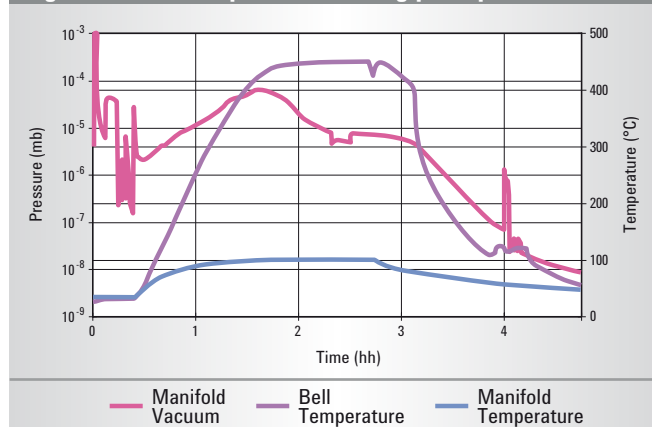

The gas analyser, placed on the vacuum system, provides the spectrum of the different gases degassed by the pump. If H₂ and the other peaks normally present in a well-baked vacuum system exceed the acceptance levels, the pump is baked again. Otherwise, it is pinched off and its base pressure monitored. The base pressure is evaluated through the ion current reading.

The current decrease is computer monitored, and the pump is ready to be shipped only after the base current is reached.

Figure 8 shows the result of the residual gas analysis performed at the end of the bake-out.

Figure 8 - Residual gas analysis

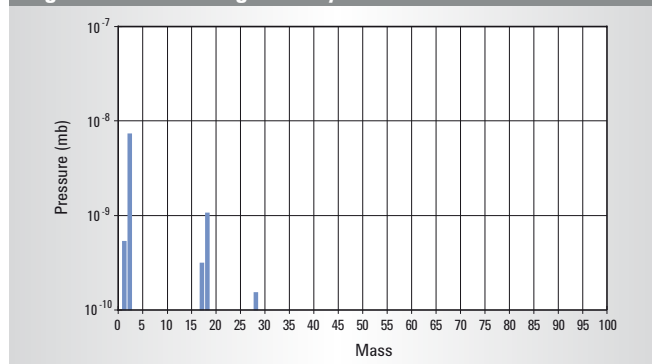

Pumping of Different Gases

In general, all ion pumps can pump all gases to some degree. To obtain the best performance and base pressure, different types of ion pumps have been developed with optimized performance in different pressure ranges and with different gases.

Agilent's Vaclon *Plus* is a complete product family that offers the choice among three different elements: Diode, Noble Diode and StarCell.

Whatever the application, there is a Vaclon *Plus* pump designed for it.

Long Operating Life

All Vaclon *Plus* pumps have rated lives in excess of many thousand of hours at a pressure of 1×10^{-6} mbar (50,000 hours for the Diode pump, and 80,000 hours for the StarCell).

With many ion pumps, maintenance may be required well before the rated life, due to metallization of insulators or pumping element distortion.

All Vaclon *Plus* elements are designed to minimize cathode distortion (even after repetitive bake-outs and starting at high pressure), and the insulators are protected from sputtered titanium by using a double re-entrant design and a cap shield.

Pressure Reading

The ability to read pressures using an ion pump is due to the direct proportionality between pump current and operating pressure.

The reliability of pressure readings at very low pressure is limited by leakage current, and the leakage current from field emission is heavily dependent on the voltage applied to the pump.

The Dual controller, designed for use with any Vaclon *Plus* pump, provides the unique ability to adjust the voltage in accordance with the operating pressure. By doing this, the leakage current is minimized at low pressure, providing a reliable pressure reading down to the 10^{-10} mbar range.

Custom Design and Flexibility

All ion pumps can be mounted in any position, and do not need any isolation valve from the system in case of venting or power failure.

Vaclon *Plus* pumps are the most compact ion pumps in each speed range. The pumps can be configured with additional flanges and can accommodate other pumping systems (like TSP = Titanium Sublimation Pump), allowing the best use of available space.

Agilent Feedthrough

The whole Ion Pump line is provided with an innovative feedthrough.

The improved feedthrough of the ion pump line is a major breakthrough. The greatest advantages of the ion pumps are listed here below:

- **Corrosion Free**

The design of the feedthrough will reduce drastically the corrosion that may occur when the pump is used in humid environments.

Our tests and experience have demonstrated that the corrosion starts and increases with the presence of humidity between feedthrough and connector. The high voltage during the pump operation ionizes the entrapped water vapor; the ions react with the brazing alloy and corrode it. The design of the feedthrough aims to solve these issues:

- On one hand the design structure of the feedthrough presents a negligible quantity of air.

- On the other hand, the brazing is done on the vacuum side so that the brazing alloy surface exposed to air is minimal.
- **High Voltage Cable Interlock**
The feedthrough has been designed for the “HV cable safety interlock” implementation. This feature avoids any electrical shock since the voltage is automatically cut off as soon as the cable is disconnected from the pump.
Our Ion Pump control unit (Dual) and the HV cable are already able to support this safety feature when connected to an ion pump with the feedthrough.
- **Easy Connection**
The connection of the cable connector to the feedthrough requires simply inserting and pushing the connector. No use of retention screws is required.
- **Safety against Unintentional Extraction**
When the HV cable connector is inserted into the new patented feedthrough, it is firmly and mechanically secured to it. A latch on the cable prevents disconnection.
- **Compactness**
The feedthrough design allows a significant gain of space for the customer.

The Vaclon *Plus* Family

Diode Vaclon *Plus*

The diode version of the Vaclon *Plus* pump has the highest pumping speed among all ion pumps for oxygen (O₂), nitrogen (N₂), carbon dioxide (CO₂), carbon monoxide (CO), and any other getterable gas. It provides the highest pumping speed and capacity for hydrogen (H₂) as well.

Its simple mechanical structure allows a reliable current/pressure reading down to very low pressures, as well as absolutely vibration-free operation. Its geometric and electrical configuration allows it to be used in the vicinity of electron detectors or similar devices.

Diode Vaclon *Plus* pumps are therefore widely and successfully used in general purpose UHV systems, for evacuating electron devices and in the most sensitive electron microscopes. However, diodes are not suggested for applications where noble gases such as argon (Ar), helium (He) and methane (CH₄) are to be pumped.

Noble Diode Vaclon *Plus*

The Noble Diode Vaclon *Plus* element is a version of the diode element, in which a tantalum cathode is substituted in place of a titanium cathode. This substitution allows a higher pumping speed and stability for pumping noble gases (mainly argon and helium).

The element is otherwise equivalent to the Diode Vaclon *Plus*. Noble Diode Vaclon *Plus* pumps are used in any application where pumping of noble gases is an important characteristic.

As with the diode configuration, the Noble Diode retains a consistent pumping speed for all gases at very low pressures. However, pumping speed for H₂ and getterable gases is lower than for the corresponding Diode. The Noble Diode Vaclon *Plus* is typically used in UHV applications where a mixture of gas is to be pumped and where the pressure is quite constant (i.e., no sudden gas burst or systematic high pressure cycling). Its characteristics of consistent speed for almost any gas even at very low pressures make it ideal whenever the ion pump alone is used to obtain UHV pressures. This is often the situation in particle accelerators or synchrotron rings, as well as in surface analysis applications.

Other Vaclon *Plus* versions are suggested whenever the application requires cycling to higher pressures, pumping of large amounts of H₂, or when the ion pump is combined with other UHV pumps such as Titanium Sublimation Pumps or Non-Evaporable Getters.

StarCell Vaclon *Plus*

The StarCell Vaclon *Plus* element is the latest variation of the Triode configuration. Its design makes this ion pump the only one that can handle a high amount of noble gases (better than Noble Diode) and hydrogen (comparable to the Diode). Furthermore, this pump provides the highest speed and capacity for methane, argon, and helium. Its high total capacity for all the different gases, together with its very good speed performance at relatively higher pressures, makes the StarCell Vaclon *Plus* ideal for applications requiring constant operation at 10⁻⁸ mbar or above. This typically includes Electron Microscopes and Mass Spectrometers.

Figure 9 - StarCell pumping element



Its high pumping speed for argon, helium, and methane (the highest of any ion pump at any pressure) has made StarCell the standard for any application where the ion pump is used in combination with TSP or NEG pumps, where its pumping performance is enhanced. The lowest attainable pressure has been obtained with combinations of StarCell Vaclon *Plus* and TSP/NEG pumps, thanks to the optimized characteristics of these combinations. Most existing particle accelerators

AGILENT ION PUMP TECHNICAL NOTES

and synchrotron sources, beam lines, transfer lines, and similar devices have used and are successfully using these combinations to obtain the maximum speed for all the gas species.

For more specific information regarding the pumping speeds for different element configurations relevant to different gases, refer to the various curves published in the Vaclon *Plus* Pumping Speed section. The aim of this section is to help you choose the best Vaclon *Plus* configuration.

Whatever the application, there is a Vaclon *Plus* version suited for it.

Do not hesitate to contact your local Agilent representative if you need more assistance in making the right choice.

For Vaclon Plus and NEG integrated pumps, please ask Agilent for a special quotation.

Vaclon *Plus* Pumping Speed

The most common parameter used to express the capability of a pump to remove molecules from a given volume is pumping speed. It is usually measured in liters per second and expresses the volume of gas (at a given pressure) removed per time unit.

In an ion pump, the net pumping effect results from the sum of different phenomena:

- The pumping action of the getter film produced by the sputtering of cathode material by ion bombardment.
- The pumping action due to the ion implantation and diffusion into the cathode.
- Gas burial on the anodes and pump walls.
- The gas re-emission from the cathode due to cathode heating and erosion.

When an ion pump is new or has been regenerated, for example by baking, the surface layer of the cathode is clean and the gas re-emission from it is negligible. In this condition, the ion pump is called “unsaturated” and the pumping effect is due both to the gettering effect as well as to ion implantation and diffusion. As the number of gas molecules implanted into the cathode increases, the re-emission of them due to the ion bombardment increases.

As a consequence, the net pumping speed decreases until an equilibrium condition between ion implantation and gas re-emission is reached. In this condition, the ion pump is “saturated” and the net pumping speed, due only to the gettering action of the material sputtered from the cathode, is about half the pumping speed of the unsaturated pump.

Since the saturation effect depends on the quantity of gas molecules implanted into the cathode, the time required to saturate an ion pump is inversely proportional to the pressure at which the pump is operated. Thus, the lower the pressure, the longer the time before the pump saturation occurs (Figure 10).

In an ion pumped UHV system with a proper bakeout procedure (and consequent pump regeneration), a pressure in the 10^{-11} mbar range is possible. At this pressure, the ion pump will work at the higher (unsaturated) pumping speed values for a few years before it is saturated.

When pump saturation is reached, the pumping speed is constant and no longer depends on the quantity of pumped gas. The values of the pumping speed curve after saturation are the lowest obtainable at any given pressure.

Generally, the ion pump works in an intermediate condition between the unsaturated and saturated extremes. The “nominal” pumping speed is defined as the maximum point on the pumping speed curve for a saturated pump; the reference gas is usually nitrogen.

The nominal pumping speed thus defines only a part of the characteristics of an ion pump. A more comprehensive description of an ion pump performance is given by the complete pumping speed vs pressure curve. By using these plots and keeping in mind the application, the best pump can be chosen.

Figure 10 - Saturation effect

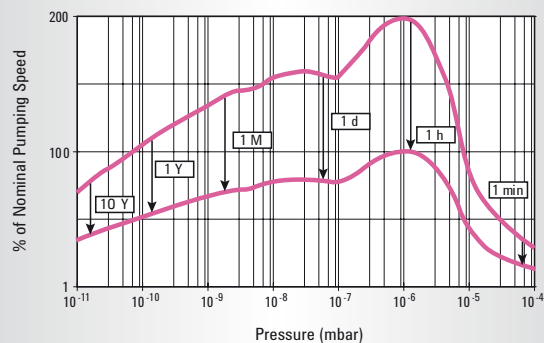

Active Gases (N_2 , O_2 , CO , CO_2 ,...)

A characteristic of these gases is their ability to easily react with most metals forming stable compounds. In an ion pump, these active gas molecules react with the fresh titanium film produced by the sputtering of the cathode material. These active gas molecules do not diffuse deeply in the cathode.

The saturation effect, due to the re-emission of these molecules trapped on the cathode surface, is very strong.

Diode and Noble Diode elements show a higher pumping speed at low pressure while StarCell elements perform better at higher pressure, because the Penning discharge is better confined inside the element (Figures 11, 12).

Figure 11 - Nitrogen pumping speed before saturation

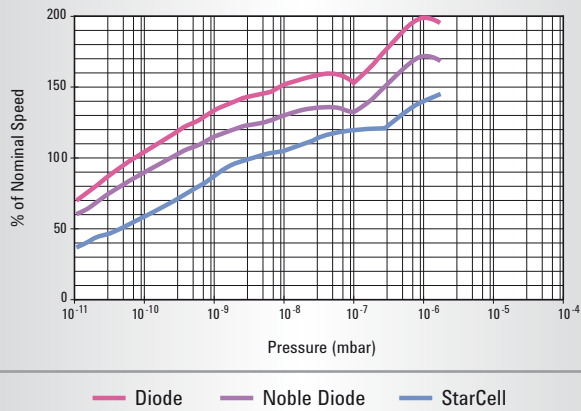

Figure 13 - Hydrogen pumping speed

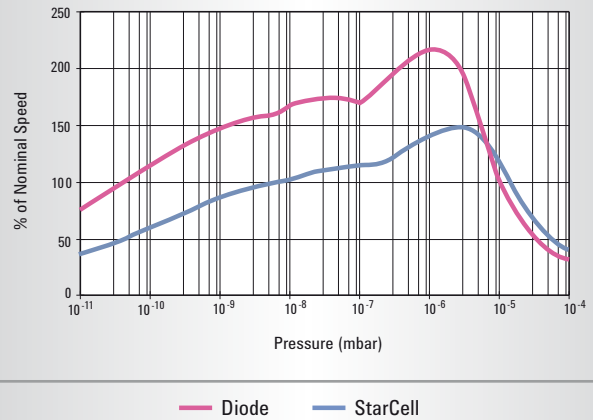
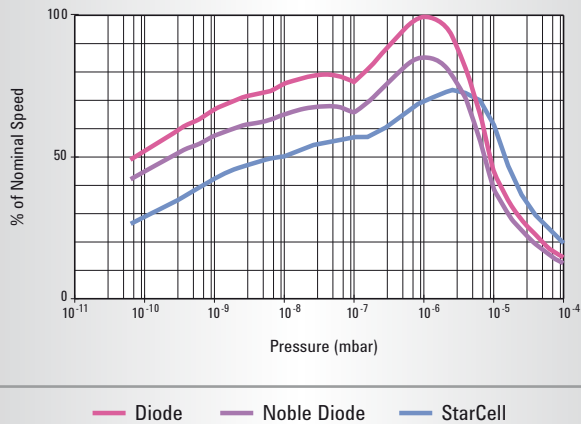

Figure 12 - Nitrogen pumping speed after saturation



Noble Gases (He, Ne, Ar,...)

The main characteristic of noble gases is that they do not react with any other element. Therefore, the film produced by the sputtering of cathode material does not provide getter pumping for helium and argon. Moreover, since these gases do not tend to diffuse into the cathode, the pumping effect due to the ion implantation is not permanent. Nevertheless, all the ion pump elements have some capacity to remove these gases.

Hydrogen

Hydrogen is an active gas but, due to its very small mass, the sputtering rate is very low. In spite of this fact, the pumping speed for H₂ is very high because it quickly diffuses into the cathode with negligible re-emission. When pumping H₂, the ion pump always works in the unsaturated condition. As a result, the nominal speed for H₂ is about twice the corresponding value for nitrogen.

Furthermore, if some traces of heavier gases are present, the increased sputtering rate produces an even higher hydrogen pumping speed.

The Diode element shows a higher pumping speed than the Noble Diode since the H₂ solubility in the tantalum cathode is lower than in a titanium cathode. StarCell elements combine good performance at higher pressures with enhanced capacity for H₂.

Figure 14 - Argon and Helium pumping speed

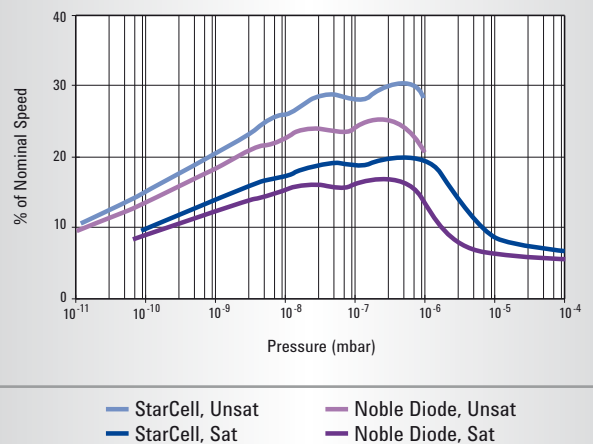

Noble gases are pumped by being buried by titanium. Noble gas ions can be neutralized and scattered from the cathode without losing their energy. These neutral atoms maintain enough energy to implant or stick on the anode and on the pump walls where they will be buried by sputtered titanium and thus permanently pumped.

AGILENT ION PUMP TECHNICAL NOTES

In the Diode configuration, the neutralization and back scattering probability is very small, thus the pumping speed for noble gases is only a small percentage of the N₂ pumping speed. Moreover, when operating at a relatively high argon partial pressure (i.e., higher than 10⁻⁸ mbar), sudden bursts of pressure due to the re-emission of temporarily implanted argon in the cathode is observed. After this occurs, a Diode pump is not able to pump more argon until its source is stopped. This phenomenon is known as “argon instability”.

Figure below shows that the StarCell pump is superior in comparison to diode pumps with differential cathodes. The test was performed at 10⁻⁵ mbar. The differential cathode diode showed instability after pumping about 3 mbar l of argon while the Starcell remained stable after pumping about 70 mbar l of argon, at which point the test was stopped.

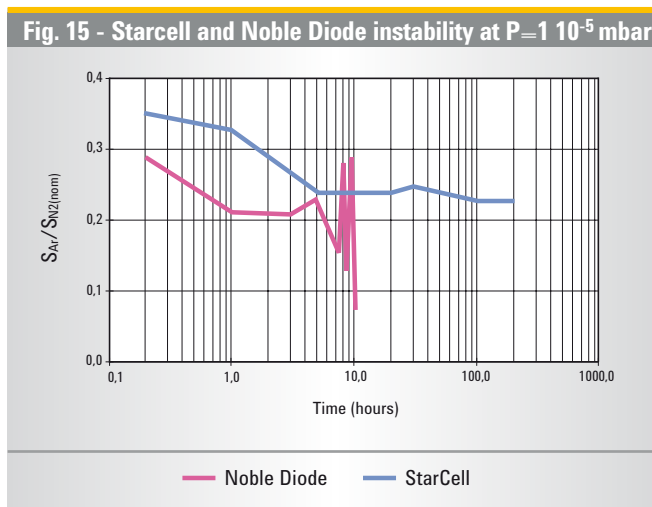

In the Noble Diode element, one titanium cathode is replaced with one tantalum cathode. The high nuclear mass of tantalum increases the back-scattering probability and consequently the pumping speed for noble gases.

The best results in terms of pumping speed of noble gases are obtained using the open cathode structure typical of StarCell elements. In these configurations, the flat cathode structure has been replaced with a structure that allows glancing collisions with ions.

These are neutralized and then forward scattered toward the pump wall or the anode with a much higher probability than in the flat cathode case. The result is a pumping speed for noble gases of up to 60% of N₂. Furthermore, due to the unique design that allows optimal use of all the available titanium, the operating life of a StarCell pump is about 50% longer than all the other pumps.

Methane

Although methane is not a noble gas, it does not react with any getter material. It is always present to some degree in UHV systems as a reaction product of hydrogen and carbon present in the vacuum system walls. Methane is a particular problem in electron accelerators where it is the main cause of the beam decay.

Figure 16 - Methane pumping speed

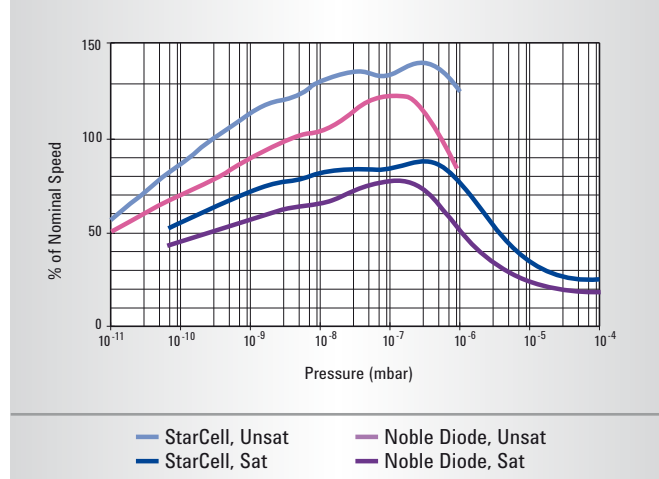

Due to the Penning discharge in ion pumps, the methane molecule (as well as other hydrocarbon molecules) is cracked and transformed into smaller getterable compounds (C, CH₃, ... H).

The result is that the pumping speed for methane and light hydrocarbons is always higher than the speed for N₂.

Basic Performance Factors

- Pumping speed, as in the case of any high vacuum pump, is one of the factors determining the ultimate (base) pressure of a system. However, ion pumps pump various gases at different rates – from very fast for hydrogen to quite slow for argon. Thus, it is necessary to check specifications to match the pump properly to the application. The pump history in terms of gas load after a bakeout also influences pumping speed. Agilent pumps are rated by their equilibrium or “saturated” speed levels. Unsaturated pumps temporarily deliver higher speeds, especially at UHV. A typical pumping speed vs pressure curve is shown on page 46.
- Maximum throughput of an ion pump is located in the 10^{-4} to 10^{-5} mbar pressure range. Since ion pumps are generally operated at much lower pressures, throughput is generally not a major consideration.
- Starting pressure is the pressure to which the ion pump must first be rough-pumped before the glow discharge will be confined to the anode cell structure and the pumping effect begins. To prevent pump overheating and possible damage when the pump is saturated at higher pressure, the controllers automatically reduce the output voltage to maintain power below a safety level.
- Pump life is determined by various factors, including cathode life; this is limited by cathode erosion, which is proportional to the average operating pressure. At 10^{-6} mbar, cathode life ranges from 35,000 to 80,000 hours.
- Bakeability. In general, baking a UHV system and its ion pump to 200 to 250 °C is adequate for outgassing, attaining low pressures after atmospheric exposure. Some processes require higher bakeout temperatures. In general, ion pump bodies can be baked at 450 °C when the magnets are removed, or 350 °C when the magnets are on the pump. When bakeable cables are connected to the ion pumps, temperature should not exceed 220 °C.

AGILENT TITANIUM SUBLIMATION PUMP TECHNICAL NOTES

Titanium Sublimation Pumps

Thin films of reactive materials have been used for “gas cleanup” or “gettering” for over a century. The early electron tube makers were only able to mechanically pump to about 1×10^{-4} mbar, but through the use of “getters” flashed on the internal surfaces, pressures in the low 10^{-7} mbar scale were attained. These getters were typically metals like barium, titanium, zirconium, or thorium. Gettering materials are still used in tubes today even though pressures of 1×10^{-8} mbar are readily attained by the pumps in the manufacturing process.

Gettering was not employed extensively in vacuum systems until the 1960’s, when it was found to be highly compatible with ion pumping. Titanium was the metal commonly used because of its availability and its ability to sublime readily over a moderate temperature range.

Applications

Due to cleanliness, bakeability, low power consumption, vibration-free operation, long pumping life, and high pumping speed, Titanium Sublimation Pumping (TSP) is the ideal cost-effective companion to ion pumping in ultrahigh vacuum.

Applications for this pumping mode are found in many areas, such as:

- Auger electron spectrometry
- Electron spectroscopy for chemical analysis
- Electron tube manufacturing
- Mass spectrometers
- Materials science conductor R&D
- Nuclear physics
- Outer space simulation
- Particle accelerators
- Secondary ion mass spectroscopy
- Solid state semiconductors

Basic Performance Factors

- **Pumping Speed.** The pumping speed of a Ti film is proportional to the film area and to the sticking coefficient, that is the probability that an impinging gas molecule reacts with Ti forming a stable compound. The pumping speeds per unit area of a fresh evaporated Titanium film are reported in Table 1. Using these coefficients the intrinsic pumping speed (S_i) of a Ti film can be evaluated using the following equation:

$$S_i[l/s] = \text{Coefficient} \times \text{Surface.}$$

Table 1

Typical pumping speeds per square inch (per square centimeter) of titanium sublimation surface for various gases (liters per second)

Gas	H ₂	N ₂	O ₂	CO	CO ₂	H ₂ O	CH ₄	Ar	He
Surface Temperature	20 °C	20 (3.1)	30 (4.7)	60 (9.3)	60 (9.3)	50 (7.8)	20 (3.1)	0	0
	-195 °C	65 (10.1)	65 (10.1)	70 (10.9)	70 (10.9)	60 (9.3)	90 (13.9)	0	0

As the gas molecules react with the surface Ti atoms, the number of active sites decreases and, as a consequence, the pumping speed decreases. A plot of the specific pumping speed vs time at different pressures is reported in Figure 17. Using this plot it is possible to estimate how frequently the Ti film has to be renewed.

It must be noted that the actual pumping speed S of a TSP depends on the conductance C between the active surface and the vacuum vessel according to the following equation:

$$1/S = 1/C + 1/S_i$$

Figure 17 - Pumping speed vs time at different pressures

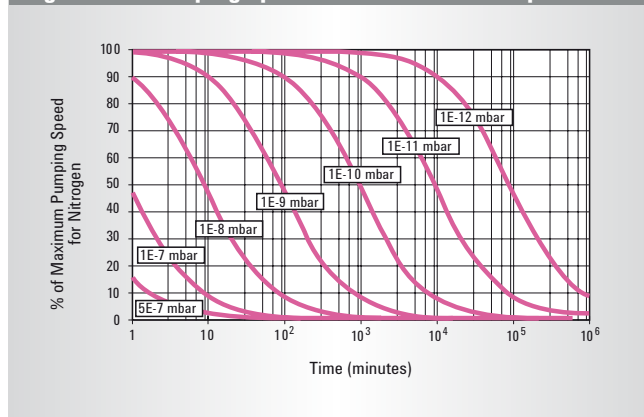

- **Throughput.** When the impingement rate of the gas molecules on the active film becomes higher than the Ti sublimation rate (excess of gas molecules respect the available Ti atoms), the pumping speed does not depend any more on the sticking coefficient. It is simply controlled by the quantity of the available Ti atoms according to stoichiometric reaction.

If n Ti atoms need to pump a gas molecule (example: $2Ti + N_2 \rightleftharpoons 2TiN$, $n = 2$), the gas throughput Q is given by:

$$Q [\text{mbar l/s}] = \frac{0.13}{n} R \left[\frac{\text{gr}}{\text{h}} \right]$$

Plus where R is the Ti sublimation rate. In this condition the pumping speed is not constant but it depends on the pressure and is directly proportional to the sublimation rate (Figure 18).

Figure 18 - Pumping speed vs pressure

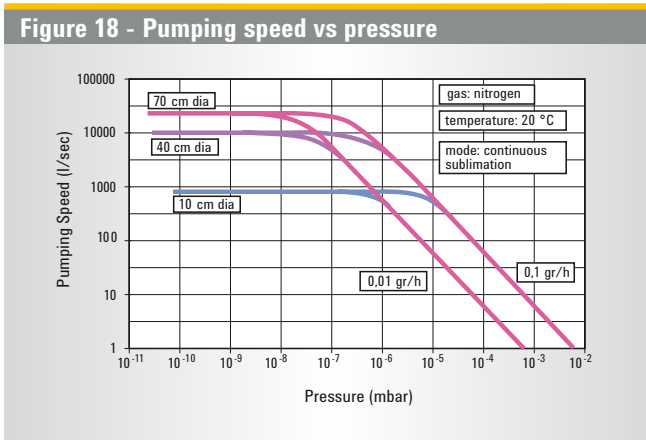

After this time the filament cartridge should be replaced.

Design Features

- All sources are mounted on 2 3/4" Agilent ConFlat Flanges and fit through 1 1/2" ports.
- The three-filament source contains 3.3 grams of useful titanium.
- The Agilent Mini Ti-Ball source contains 15.2 grams of useful titanium.

- Other factors. The overall performance of a titanium sublimation pump is a function of several variables, including gas species, pressure, gas temperature, getter film temperature, getter film area, the geometry of the area, sublimation rate, sticking coefficient, and the conductance from the film to the area being evacuated. For further information, write for "Predicting and Evaluating Titanium Sublimation Pump Performance" by D.J. Harra, 1974 (Vacuum Report VR-88).

Operation

Titanium Sublimation Pumping is accomplished by coating the inner surfaces of a vacuum system with sublimed titanium films. Since it involves a chemical reaction, this kind of pumping is useful where mainly active gases are present.

The pumping speed of a unit area varies with various reactive gas species as shown in the following table. It can also be seen that cooling the substrate to liquid nitrogen temperature markedly increases the speed for hydrogen and water.

The gases thus "gettered" form stable compounds with titanium and are stored in the system as such until they are removed by cleaning. Since there is generally un-reacted pyrophoric titanium buried in the deposits, caution should be used in cleaning. If the desired gas throughput is known ($Q = \text{pumping speed} \times \text{pressure}$) the maximum theoretical operating time is given by:

$$\text{Operating time [h]} = \frac{0.13}{n} \frac{T [\text{gr}]}{Q [\text{mbar l/s}]}$$

where T is the usable Titanium

For example, using our cryopanel at 1×10^{-8} mbar with a three filaments cartridge Ti source, the theoretical operating time is given by:

$$\frac{0.13}{2} \frac{3.6 [\text{gr}]}{500 [\text{l/s}] \times 10^{-8} [\text{mbar}]} = 46,800 \text{ hrs} = \text{about 5 years}$$

AGILENT ION PUMP SERVICE AND SUPPORT PLAN

Agilent Vacuum Technologies Products offers one of the most comprehensive service and support plans in the industry.

As a worldwide, first class company we strive to offer added value to our Customers wherever they may be located.

Excellence in Service and Support is a key factor in added value.

Support can be accomplished with qualified Engineers and an appropriate logistic infrastructure.

Technical skills and infrastructure are two areas where we are continuously making medium and long-term investments.

Our daily customer support philosophy is focused on two important factors: quick response and no hassle.

Agilent Vacuum Products is committed to providing our Customers with the most comprehensive service plans possible.

The following pages detail the standard sections of our Ion Pump Service and Support Plan. For more information, or if you have a need for customized solutions, please contact your Agilent representative.

Often, excellent products are not enough: Agilent’s constant presence with Customer Service as a responsive partner is what really makes a difference.

Worldwide Parts Sourcing Plan

• Exchange and Repair Programs

Agilent’s Ion Pumps and Controllers offer unmatched reliability, performance and cleanliness.

To maximize uptime, and for those occasions where time is essential, Agilent offers Ion pump controller exchange units for advance shipment.

Exchange units are fully remanufactured to the same strict standards as new products.

If requested, your Exchange unit can be shipped for overnight delivery. This efficiency is due to our logistic infrastructure and is the result of excellent teamwork among our Service and Customer Service Teams!

The Repair Program is available for those situations where the control of assets is important and when the requested turn around time is less critical.

The Exchange and Repair Programs allow global OEMs and End-Users consistent delivery time, pricing, part numbers, and order processing procedures.

• End User Extended Warranty

The End User Extended Warranty is a Service Agreement that provides coverage extension beyond the standard 12 months warranty of a product. It extends for additional 12 months the coverage from failures due to defects in material and workmanship.

By extending the warranty of purchased products, post-sales satisfaction is guaranteed. This is the result of the relevant cost decrease while cost predictability is increased.

The End User Extended Warranty has been designed to cover the needs of the High Energy Physics Ultra High Vacuum applications.

• Ordering Information for End User Extended Warranty High Energy Physics UHV Applications

Pumps	Part Number
Extd. Warr. HEP 12M Ion Pump 20 l/s class	EW919VIP20
Extd. Warr. HEP 12M Ion Pump 40 l/s class	EW919VIP40
Extd. Warr. HEP 12M Ion Pump 55 l/s class	EW919VIP55
Extd. Warr. HEP 12M Ion Pump 75 l/s class	EW919VIP75
Extd. Warr. HEP 12M Ion Pump 150 l/s class	EW919VIP150
Extd. Warr. HEP 12M Ion Pump 300 l/s class	EW919VIP300
Extd. Warr. HEP 12M Ion Pump 500 l/s class	EW919VIP500
Extd. Warr. HEP 12M Ion Pump (other config.)	EW919VIP

Controllers	Part Number
Extd. Warr. 12M Minivac Controller	EW929MINIVAC
Extd. Warr. HEP 12M 4UHV CTRL 1-2 Pumps	EW919UHV2P
Extd. Warr. HEP 12M 4UHV CTRL 3-4 Pumps	EW919UHV4P
Extd. Warr. 12M TSP Controller	EW929TSP

Technical Assistance

As a Agilent Customer, you can rely on an attentive and professional support staff, dedicated to providing you with the easiest and most personalized service possible.

• Customer Support

Our toll-free lines, with mother tongue Technical Support Engineers at worldwide locations, allow us to provide you with quick, corrective responses to your needs.

Whenever a new problem is identified and solved by our support personnel, it is entered into our technical support system and becomes available to all Agilent technical support centers. This system allows all Agilent locations to provide excellent first and second level technical support to customers worldwide. In addition, the technical support centers are in daily contact with our R&D departments for third level support.

Call us today for more information.

Americas

North America: Toll-Free +1 800-882-7426
Fax +1 781-860-5437
Central and South America: Tel. +1 781-861-7200
Fax +1 781-860-5437

Asia

Japan: Toll-Free +81 120-477-111
Fax +81 120-880-598

Korea: Toll-Free 080-222-2452
Fax +82 (0) 2-3452-3947

China: Beijing Office Toll-Free 800-820-3278
Fax +86 (0)10-6439-2765

Shanghai Office Toll-Free 800-820-3278
Fax +86 (0)21-6628-5169

Guangzhou Office Toll-Free 800-820-3278
Fax +86 (0)20-8669-5861

Shenzhen Office Toll-Free 800-820-3278
Fax +86 (0)755-8276-3181

Taiwan: Toll-Free 0800-018-768

Singapore: Toll-Free 1800-276-2622

Malaysia: Toll-Free 1800-880-805

India Toll-Free 1800-1801-517

Europe and Israel

Austria, Belgium, Finland, France, Germany, Holland, Ireland, Israel (*), Italy, Portugal, Spain, Switzerland, UK:

Toll-Free 00-800-234-234-00

Toll-Free-Fax 00-800-345-345-00

(*) From Israel dial 012 instead of initial 00

Other Countries

Tel. +39 011-9979-369

Fax +39 011-9979-330

• Application Support - Application Training

Agilent has a leadership position in vacuum technology with continuous search for innovative solutions through research and development.

To meet the most demanding needs, our Application Engineer Team can bring our knowledge into your factory.

Application Support is a project-based activity where our experts assist you towards the solution of your application issues that might arise both at pre and post-sale level.

By designing solutions that meet Customers' needs, Agilent aims to create a positive and synergetic relationship with customers.

Our experts can keep you well-informed and up-to-date on industrial and scientific applications with the goal of optimizing the use of our products on your system as well as the development of new vacuum techniques.



AGILENT TURBO PUMPS

2-5	Introduction
6-7	Molecular Drag Technology
8-9	Agilent Floating Suspension
10-11	Turbo Pump Technology
12-13	Turbo Pump Technology for Instrumentation
14-17	Typical Applications
18-55	Turbo Pump Models
56	Accessories
57-59	Technical Notes
60-62	Service and Support Plans



Agilent Technologies

The Agilent Advantage

A complete family of Turbo Pumps including the innovative break-through TwisTorr FS pumps.

- Agilent turbo pumps are designed for reliability and optimum performance in real world applications to meet highest quality standard
- Our pump range also includes integrated pumping systems, multiflow pump solutions for scientific instruments, and dedicated solutions for vibration-sensitive applications in nanotechnologies

2013 • Agilent introduces the new TwisTorr 304 FS, with Agilent Floating Suspension



2010 • Agilent Technologies presents the new TwisTorr molecular drag technology based on its well-known hybrid Turbo Molecular Pump design, introducing a spiral drag section that achieves unmatched performance in both pumping speed and compression ratio in the most compact space available. New state-of-the-art electronics complete this industry leading Turbo Molecular Pump innovation



2004 • Varian develops a dedicated range of SEM products that meets the most stringent requirements of the industry



2003 • With the Turbo-V 2K-G Varian, now Agilent, introduces a fully integrated Turbo system



1996 • Introduction by Varian of microprocessor-based on-board controller units: Navigator line, for computer driven plug-and-pump operation



1991 • Varian introduces a new hybrid type Turbo Molecular Pump: one monolithic rotor provides both high speed (Turbo stages) and high foreline tolerance (MacroTorr stages)
• Use of ceramic ball bearings with life-time lubrication using a proprietary dry solid lubricant



1986 • Varian starts an innovative pilot project to develop turbomolecular pump technology in collaboration with Italian hi-tech company Elettrorava



Turbopump Operating Principles

Turbomolecular pumps consist of a series of bladed impellers rotating at high speed and fixed bladed stators. These impellers and stators are alternately spaced and are inclined in opposite directions.

The pumping action is based on momentum transfer from the fast moving impeller surface to the gas molecules. The speed of the moving surface must be as high as possible to achieve optimum pumping efficiency in terms of pumping speed and compression ratio. When this mechanism takes place several times in a pump a pumping action is created. The sequence of alternating rotors and stators typical of a conventional

turbomolecular pump develops the compression ratio. Turbomolecular drag pumps operate according to the same principle, but with a different geometry in the pumping stages. Gas molecules collide against a fast moving wall and are dragged into a channel toward the high pressure region. Conventional turbomolecular pumps have high pumping speed but low compression ratio at foreline pressures higher than 10^{-1} mbar. Molecular drag pumps have low pumping speed but high compression ratios up to foreline pressures of more than 20 mbar. When the two types of stages are combined together in one pump, extended operational pressure ranges can be achieved.

TURBO PUMPS

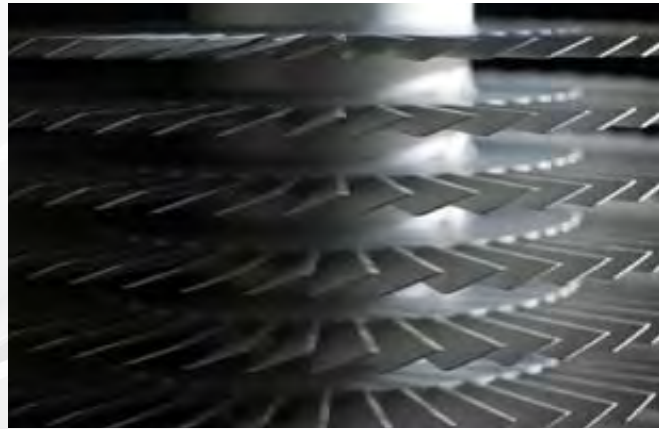

Turbomolecular Pump Parameters and Definitions

Throughput

“Throughput” is the flow rate of pumped gas through the turbomolecular pump (and foreline pump).

Throughput (Q) is measured in mbar l/s 1/60 standard cm³/min. The maximum throughput a pumping system can handle is, in general, dependent upon the size of its foreline pump rather than the turbomolecular pump.

Pumping Speed

“Pumping speed” (S) (volumetric flow rate) of a turbomolecular pump is the ratio between throughput and inlet pressure (foreline pump size must be the recommended one as a minimum).

$$S = Q / p$$

The pumping speed of a turbomolecular pump is constant over a wide pressure range and depends upon geometric factors such as diameter and rotational speed. For most turbomolecular pumps, pumping speed is nearly independent from gas species (molecular weight).

Compression Ratio

“Compression Ratio” is the ratio between foreline (partial) pressure and inlet (partial) pressure for a given process gas, measured in “zero flow” conditions (performed by injecting the process gas in the pump foreline while the high vacuum port is blanked off).

Compression ratio is generally indicated with the letter “K”. In technical specifications of turbomolecular pumps, it is the maximum attainable value of K (at low foreline pressure). Compression ratio is, in fact, a function of the foreline pressure as shown in Figure 1.

Compression ratio decays at high pressure depending on turbomolecular pump configuration (the number of molecular stages) and/or power limitations that slow down the rotor (gas friction increases with pressure).



INTRODUCTION

The maximum compression ratio is strongly influenced by gas species: it is an exponential function of the molecular weight of the pumped gas (compression ratio is considerably lower for light gases).

Pumping Speed and Pressure Ratio

The pressure ratio between foreline and inlet pressures in each operational situation is indicated by "Rp". This is, in general, equal to pumping speed ratio

$$R_p = P_{foreline} / P_{inlet} = S_{eff} / S_{foreline}$$

where S_{eff} is the effective pumping speed, and $S_{foreline}$ is the pumping speed of the foreline pump.

In fact

$$Q = S_{eff} P_{inlet} = S_{foreline} P_{foreline}$$

therefore

$$S_{eff} / S_{foreline} = P_{foreline} / P_{inlet}$$

The pumping speed of a turbomolecular pump is minimally affected by pressure ratio (and foreline pump size) in most common operational conditions (when pressure ratio is much smaller than K).

Generally, however, the effective pumping speed " S_{eff} " is a linear function of the pressure ratio " R_p " as shown in Figure 2 (and therefore is also dependent upon the size of the backing pump).

S_{eff} reaches its maximum value "S" (nominal pumping speed) when " R_p " equals unity, and it is zero when the pressure ratio R_p has reached its maximum value "K".

This linear dependence can be expressed by the following relationship:

$$S_{eff} = S / (1 - 1 / K + S / S_{foreline}K) \tag{1}$$

As it can be seen:
when

$$K \gg S / S_{foreline}$$

and

$$K \gg 1$$

then

$$S_{eff} \approx S$$

when

$$K \approx 1$$

then

$$S_{eff} = S_{foreline}$$

The above formula (1) must be used to evaluate pumping speed when operating at high pressure, especially with light gases (low K).

Base Pressure

The base pressure of a turbomolecular pump is the equilibrium pressure between outgassing of pump surfaces exposed to high vacuum, including test dome, and the pumping speed of the pump.

$$P_{base} = Q_{outgas} / S_{eff}$$

In the case of ultimate operational pressure, as specified by norms, the pressure is measured after 48 hours bakeout of pump and dome (provided with metal gasket); therefore the prevailing outgassing product is H2 and equilibrium is reached with hydrogen pumping speed.

$$P_{base} = Q_{H2} / S_{effH2}$$

When foreline pumps with relatively high base pressures are used, base pressure is sometimes limited by the compression ratio for H2O (or N2).

$$P_{base} = P_{forelineH2O} / K_{H2O}$$

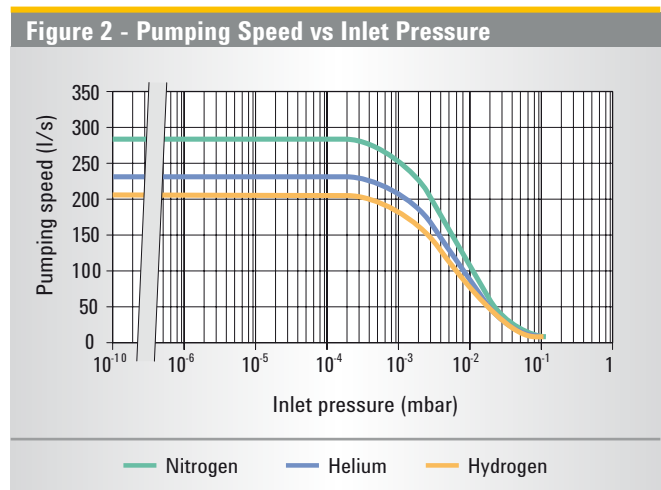
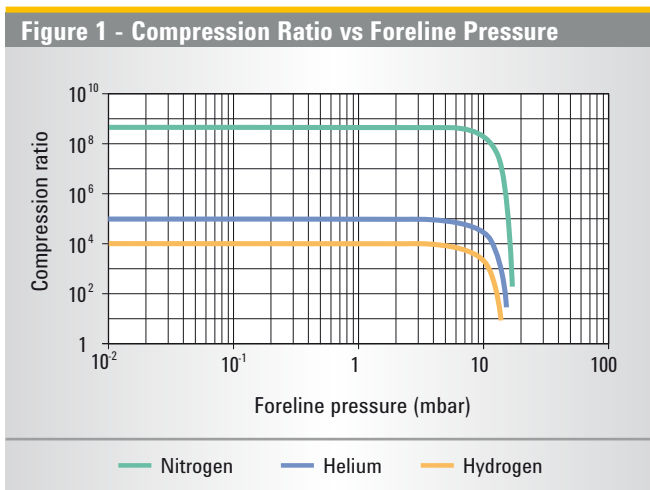



Pump Selection

How to Select a Turbo-V Pump

The right choice of a turbomolecular pump depends on the application; as a general rule we can reduce the choice to two types of use:

UHV (no gas flow) operations and Process Gas flow operations.

– UHV (no gas flow) operations.

The former case includes most cases in which the turbomolecular pump is employed to create vacuum in systems where the gas load is mainly produced by outgassing. In this application the choice is typically based on the desired base pressure within a desired time as a function of the foreseen outgassing rate, i.e.

$$S_{\text{eff}} = Q / p$$

where:

- p is the desired base pressure (mbar)
- Q is the total outgassing rate at the desired time (mbar l/s)
- S_{eff} is the effective pumping speed

– Process Gas flow operations.

The second case relates to all operations where process gases must be used. The main parameters are therefore the desired operation pressure and the process gas flow

$$S_{\text{eff}} = Q' / p'$$

where Q' is the total gas flow and p' is the operating pressure.

How to Select the Backing Pump of a Turbomolecular Pump

The selection of a backing pump should be based analyzing two requirements of the vacuum system:

- a. the roughing time
 - b. the minimum recommended backing pump of the turbo
- a. Roughing: once the desired roughing time is established, the size of the forepump can be determined through the following formula:

$$S_{\text{foreline}} = (V / t) \ln (p_0 / p_1)$$

where

- S_{foreline} is the pumping speed of the roughing pump (l/min)
- V is the volume of the chamber to be evacuated (l)
- t is the desired roughing time (min)
- p_0 is the starting pressure (mbar)
- p_1 is the end pressure (mbar)

When using a foreline pump much larger than the recommended size, a by-pass line might be necessary to achieve calculated roughing time.

- b. Backing: the backing pump must be big enough to achieve an effective pumping speed as close as possible to the nominal speed.

$$p_{\text{foreline}} = Q / S_{\text{foreline}}$$

where

- S_{foreline} is the pumping speed of the foreline pump
- Q is the gas load
- p is the operating foreline pressure

It should be noted that Q is the total gas load on the pump and includes process gases and turbo purge gases when used.

The size of the backing pump can be calculated according to the following rule:

$$S_{\text{foreline}} \geq 20S / K$$

where

- S is the pumping speed of the turbopump
- S_{foreline} is the pumping speed of the backing pump
- K is the maximum compression ratio of the turbopump for a given gas (i.e.: process gas) at the operating foreline pressure.

The pumping speed of the backing pump should be the higher of the two values calculated as above (roughing and backing).

Finally, it is possible to use a dry pump (scroll or diaphragm) for hydrocarbon-free operation when pumps of the MacroTorr type are used.

MOLECULAR-DRAG TECHNOLOGY

Drag Technology allows higher foreline pressure, higher efficiency and smaller backing pump in a very compact design. Agilent solutions are designed using state of the art, proprietary numerical modeling. We offer optimized solutions for:

- Pumps with high compression ratio for UHV applications requiring lowest base pressure
- Pumps with high pressure differential for high throughput
- Pumps with high discharge pressure allowing downsizing of the complete vacuum system

Agilent developed two innovative molecular drag stages technological platforms: TwisTorr and MacroTorr.

AGILENT TWISTORR TECHNOLOGY*

- Pumping effect is created by a spinning rotor disk which transfers momentum to gas molecules
- Gas molecules are forced to follow spiral groove design on the stator. The specific design of the channel ensures constant local pumping speed and avoids reverse pressure gradients, minimizing power consumption

(* US Patents applications 12/343961 and 12/343980, 24 Dec. 2008.

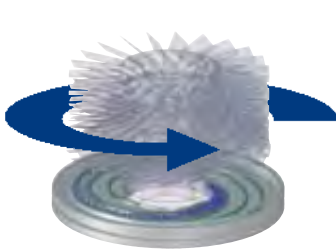

Centripetal pumping action

Lower surface area of rotating disk transfers momentum to gas molecules
Spiral groove design on the upper section of the TwisTorr stator causes a **centripetal** pumping action (**Blue** colored gas flow)



Centrifugal pumping action

Upper surface area of rotating disk transfers momentum to gas molecules
Spiral groove design on the lower section of the TwisTorr stator causes a **centrifugal** pumping action (**Red** colored gas flow)

Loading Edge Performance

- The TwisTorr Pumps offer the highest pumping speed in their category for all gases
- The state of the art TwisTorr technology also achieves the highest compression ratios for light gases in a commercially available Turbo Molecular Pump
- Besides offering the highest performance, average power consumption results particularly low

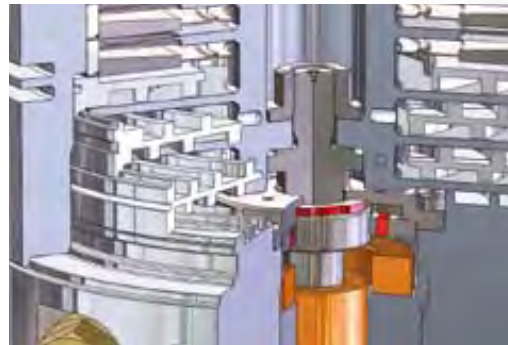

Gas flow in centripetal and centrifugal direction through TwisTorr channels

Space Saving Design

- Our rotor is based on the proven Agilent monolithic rotor design which positions the TwisTorr Stator between two smooth spinning disks and therefore exploits the pumping action by both disk surfaces in series
- The double-sided spiral groove design on the TwisTorr stators combines centripetal and centrifugal pumping action in series, greatly compacting the size of the drag section

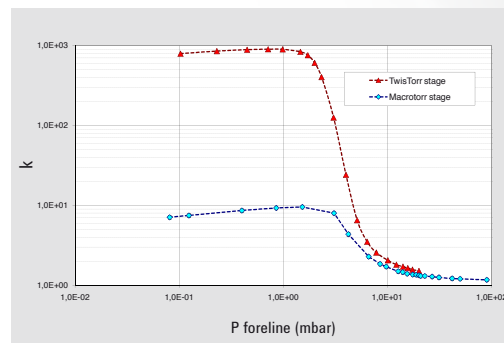

Compression Ratio

- Compression ratio for N₂ of a single TwisTorr stage can increase up to a factor of 100 with respect to a conventional stage of the same space and rotor speed, providing exceptional foreline tolerance and pumping speed

TURBO PUMPS

TwisTorr Technology in Agilent Turbo Pumps



Turbo section: turbo stators

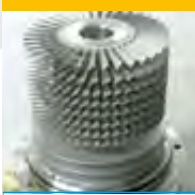

Turbo section: aluminum rotor with turbo stages designed to optimize pumping speed for light gases



Drag section: New TwisTorr technology TwisTorr drag stages (spiral channels) designed for high compression ratio performances

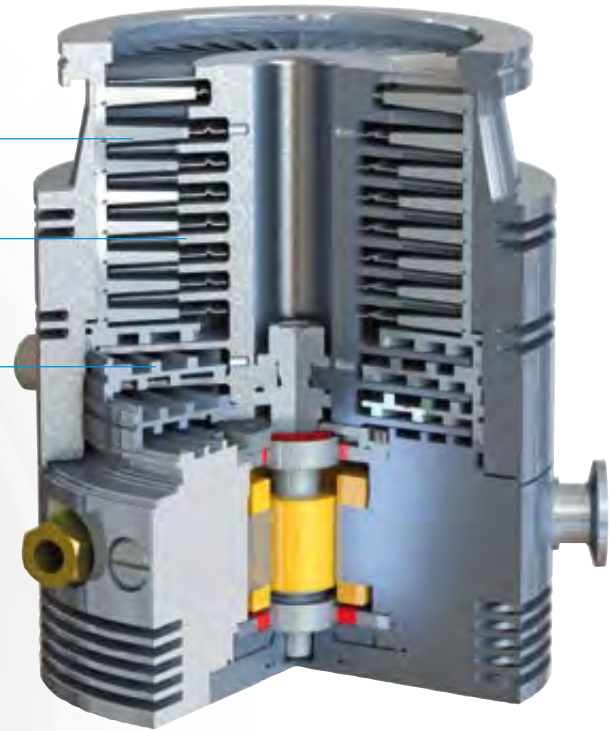

AGILENT MACROTORR TECHNOLOGY

The MacroTorr Concept

Agilent patented MacroTorr design is based on the idea of replacing (rather than adding) molecular impeller disks to some turbo bladed stages.

The molecular impellers consist of a disk rotating in a channel in which the inlet and outlet are divided by a wall.

The cross section of the channels decreases from the top to the bottom of the pump (from high vacuum to low vacuum or from the low pressure to the high pressure zone).

Gas molecules gain momentum after each collision with the moving surface of the impeller. The gas is then forced to pass through a hole to the next stage due to the wall.

The result is a product that, with the same dimensions as a conventional turbopump, provides: high compression ratios for light gases and high compression ratios at high foreline pressure. This allows the use of a very small mechanical pump while maintaining a low inlet pressure, or the use of a dry pump, for an oil free environment, and high throughput capacity at inlet pressures greater than 10^{-3} mbar.

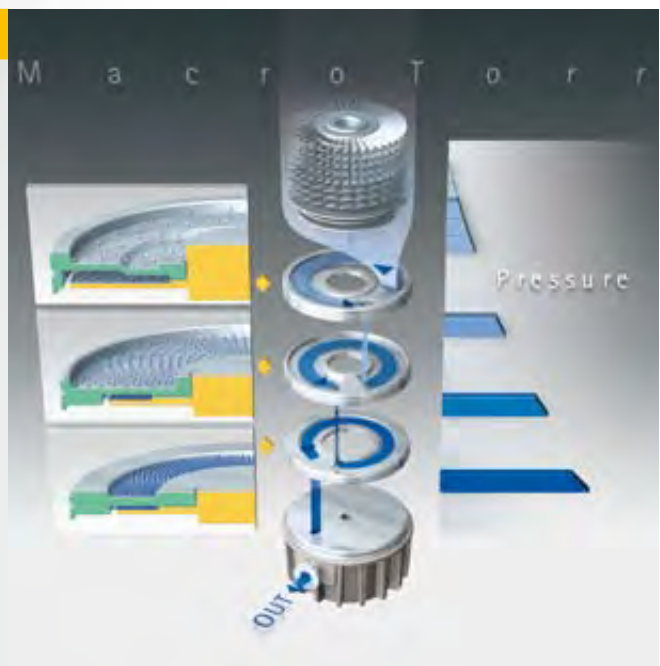

FLOATING SUSPENSION

AGILENT FLOATING SUSPENSION

The Turbomolecular pumps' rotor rotates at very high speed to provide the necessary pumping effect. In that operative mode there are several crucial parameters to be rigorously controlled and managed:

- radial positioning
- axial alignment
- bearings axial pre-load

Agilent designed a patented innovative suspension technology that gives to Agilent Turbo Pumps the best dynamic behaviour, resulting in low noise, low vibration and longer bearings' life.

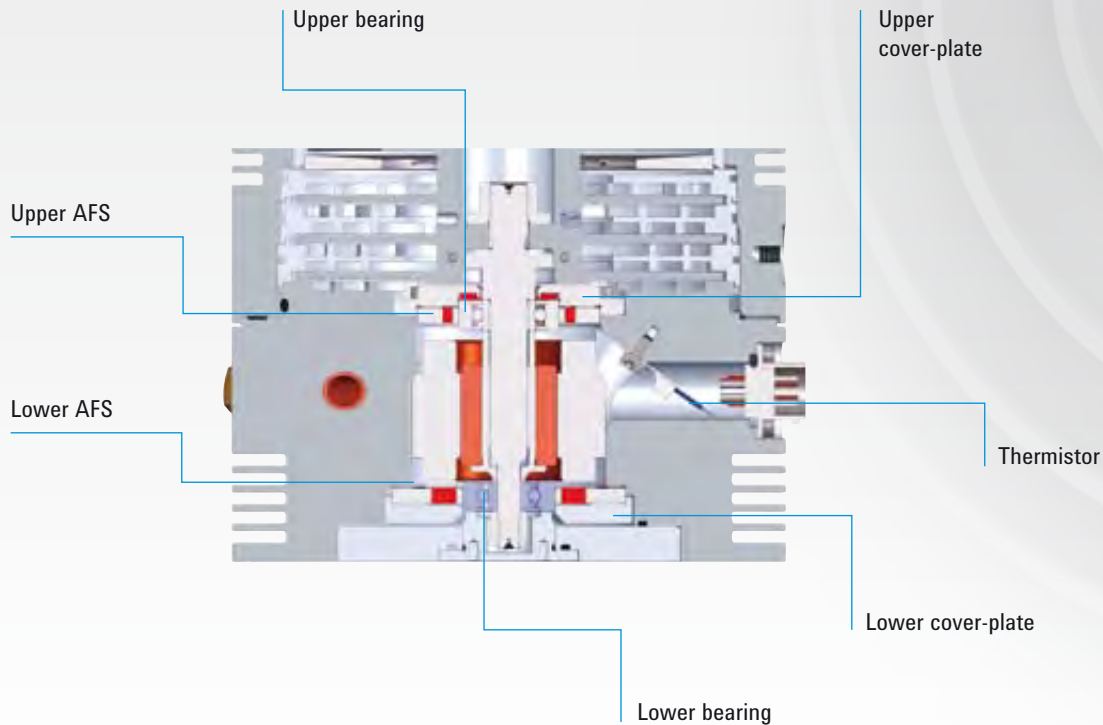

Mechanical Design

SST shaft screwed on Al rotor to provide rotor stability (bending effect, behaviour under external shock loads)

Agilent Floating Suspensions (AFS)

- AFS geometrical precision to guarantee bearing alignment
- Designed radial stiffness to optimize rotor dynamic behaviour and acoustic noise
- Lower AFS acts as an axial spring to provide bearing's constant pre-load and rotor axial positioning
- Thermal stability
- Vibration stability over time

TURBO PUMPS

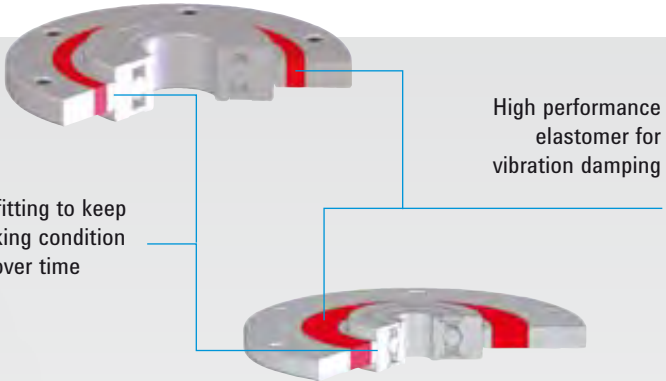

Radial press fitting to keep the best working condition for bearings over time

High performance elastomer for vibration damping



- AFS geometrical precision guarantees perfect bearings alignment
- Designed radial and axial stiffness, optimized rotor dynamic behaviour and acoustic noise
- Lower AFS acts as an axial spring providing bearing's preload and rotor axial positioning
- Thermal stability



Lower AFS

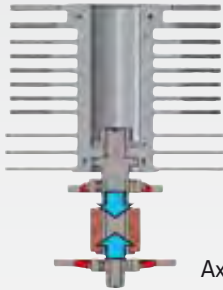
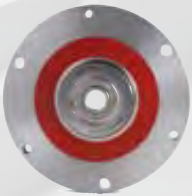

Axial bearings pre-load

Floating rotor to improve vibration damping and control

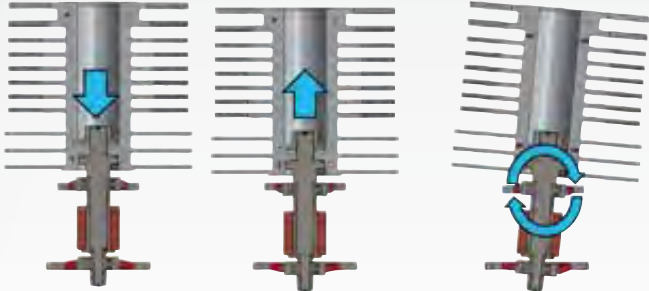

TURBO PUMP TECHNOLOGY

Wide Pumping Speed Range: 80 to 2,200 l/s

Agilent offers a complete range of turbomolecular pumps, to cover all applications and market segments.



Controllers

- Various configurations available to match each application's requirements
- Rack type display controllers, to match your existing system architecture
- Low voltage - PCB units, to fully integrate turbopump electronics into your system's electronics
- Navigator on board controllers, for plug-and-pump operation driven by the computer of your system
- Truly integrated electronics, completely embedded in the pump body

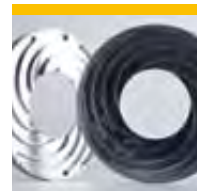

Molecular Drag Technology & Pumping Efficiency

- MacroTorr and TwisTorr technologies allow higher foreline pressure, higher efficiency and smaller backing pump, in a very compact design
- Agilent R&D Team has the capability to optimize the pump performances for different applications

TURBO PUMPS

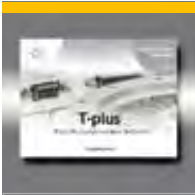

Controller and T-plus SW

- T-plus Software runs on a PC or laptop and is an effective operation and trouble shooting interface
- It enables complete remote control of the pump
- It is available for all controllers, when equipped with serial port, for data logging and displaying

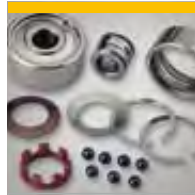

Ceramic Ball Bearings

- Agilent was the first to introduce permanently lubricated ceramic ball bearings in turbomolecular pumps in 1992
- From there, bearings' quality and reliability have dramatically improved
- Now typical MTTF well exceeds 200,000 hours



Application Specific Solutions for SEM

A complete line of turbo pumps dedicated to Electron Microscopy.
(See page 12-13)

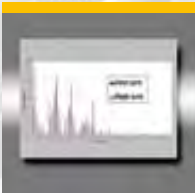

Oil Free - Permanent Lubrication

- Permanent lubrication is possible thanks to the extremely low vapor pressure of the solid lubricant
- This solution allows pump operation in any position
- No maintenance, no oil, no refill and most important no contamination

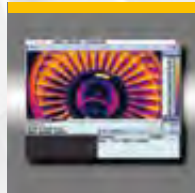

Thermal Efficiency & Temperature Control

- The correct design of pumping stages, motor and electronics allows low heat dissipation and low power consumption
- Total temperature control within the pump is important for reliable long-term operation. All our pumps are equipped with at least one temperature sensor
- Controllers manage temperature information related to other operational parameters, for an evenly distributed and controlled temperature within the pump
- These, in combination with efficient air and water cooling systems, are key factors for reliability, in any application

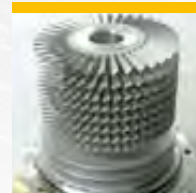

Rotor

- Suspension axial/radial perfect positioning
- Vibration damping
- Correct bearing pre-load

TURBO PUMP TECHNOLOGY FOR INSTRUMENTATION

The Agilent Advantage: Masters in Mass Spec and Nanotechnology

As the leading Ultra-High Vacuum products supplier, Agilent Technologies has long been working with all MS, SEM and TEM manufacturers, providing application specific solutions.

Today Agilent is the only company able to offer a complete and dedicated range of MS and SEM products, including primary pumps, turbomolecular pumps, ion getter pumps, and vacuum measurement, that meet the most stringent requirements of the industry.

Turbo-V SEM versions are available on request; please ask Agilent for technical details.

Vacuum for SEM: basic requirements

- Vacuum in the gun and sample chamber must be particle-free and oil-free
- **No** Vibrations
- **No** Resonances
- **No** Magnetic stray fields from both IGP and TMPs
- **No** Electric noise from power supplies
- **Fastest** Pumpdown cycles
- Pressure levels stable and controlled
- Maximum Uptime
- Fast, worldwide Service Support

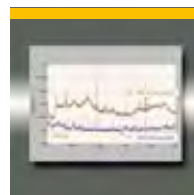

Superior Vibration Isolation System

- Lower vibrations than Mag-Lev!
- Certified Computer Aided Balancing, thanks to suspended benches with special high sensitivity accelerometers



Foreline Pressure up to 15 mbar

- Ideal to minimize forepump size (i.e. IDP-3 Dry Scroll Pump, DS 42 Rotary Vane Pump), resulting in the lowest cost of ownership

TURBO PUMPS



Improved Roto Dynamics

- Designed to avoid internal mechanical resonances
- Agilent SEM turbopumps are designed to minimize vibration sources, and have a very stable vibration profile



Enhanced Electronic Controllers

- Universal voltages
- Integrated Vent valve command, adjustable valve delay and opening time
- Pressure gauge reading
- Integrated Profibus

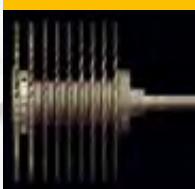

Monolithic Rotor

Mounting in any position, with no limitations.

- Rugged design
- Light weight
- Air inrush proof
- Earthquake proof



Magnets Free Design

- Lowest Magnetic Signature in the industry
- Best to work very close to ebeams
- No need for magnetic shields



Integrated Double Dampers

- Agilent developed special Integrated Double Dampers for the most demanding SEM applications
- Damping factor up to 1400X (Radial, at unbalance level, with IDD100 ISOK): better than Mag-Lev!
- Best SEM image resolution

AGILENT TURBO PUMPS TYPICAL APPLICATIONS

Research and Development Particle Accelerators

- Turbomolecular pumps are widely used in High Energy Physics, Fusion Technology and general UHV research. Synchrotron Light Sources, Particle Accelerator Rings, UHV Laboratory research, and Fusion reactors need extremely clean, reliable and cost effective HV and UHV.F Maintenance-free pumps are specifically required, because most pumps are not easily accessible.
- Agilent turbomolecular pumps are designed to offer unmatched reliability, performance and cleanliness for these applications. Ceramic bearing pumps, thanks to their reduced rolling friction, low stress and high thermal stability compared to conventional bearings, deliver longer operating life. Ultra low vapor pressure solid lubricant eliminates the need for maintenance and assures clean operation under any operating conditions.
- Furthermore, in contrast to most of the other pumps, all Agilent turbopumps have both the upper and the lower bearing in the rough vacuum side and not exposed to UHV, further reducing the possibility of contamination - even in case of misuse.

- The patented TwisTorr stages provide the highest speed and compression ratio in the smallest footprint; furthermore all Agilent turbopumps can truly be mounted in any orientation, from vertical to horizontal to upside down, aiding system design in the most stringent space requirements.
- Agilent turbopumps can operate at higher foreline pressures, allowing the use of dry roughing pumps, thus providing a completely clean, oil-free compact and cost effective pumping package.
- Whenever a large amount of gas has to be pumped and higher throughput is needed, the combination of TwisTorr pumps and TriScroll dry pumps is the state-of-the-art solution. All Agilent turbopumps have integrated or on board controller versions allowing easy plug and pump operation, or a rack-mounted controller for applications where the electronics need to be remotely placed (i.e. radioactive environments).

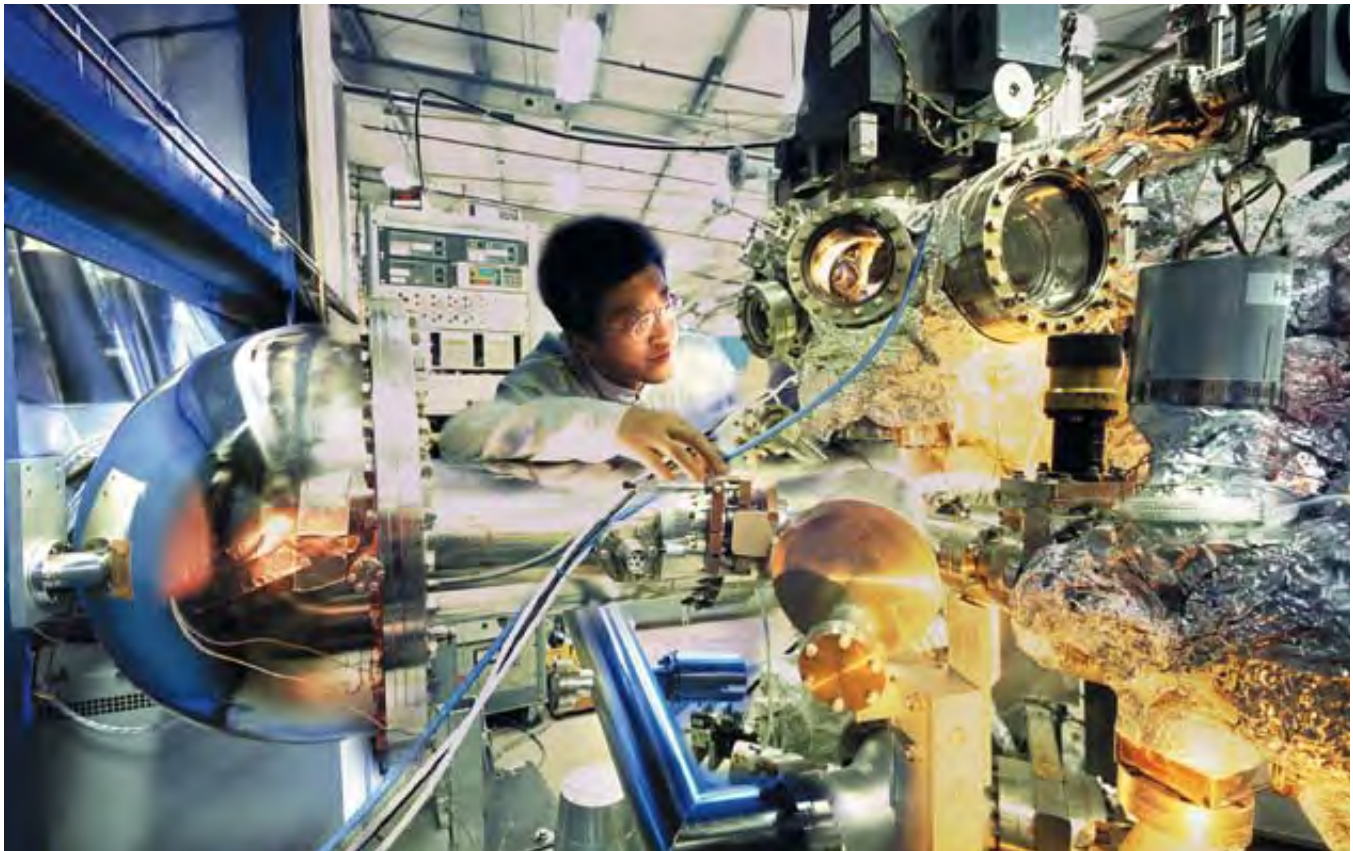



Courtesy TRIUMF-ISAC.

Instrumentation

Electron Microscopy (SEM, TEM), Focused Ion-beam Systems (FIB) and Surface Analysis

- Modern focused-beam systems such as SEM's, TEM's and FIB's utilize columns that project electrons or ions onto microscopic samples for detailed analysis. End users analyze all types of substances from organic compounds to semiconductor wafers. In the Semiconductor industry, in particular, they require more sensitivity for better sample resolution. Another key requirement is high sample throughput in order to lower the cost of ownership of these instruments.
- Based on these requirements, the demand for high performance vacuum pumps is greater than ever. Agilent offers a full range of high and ultra-high vacuum pumps designed especially for the demanding requirements of SEM's, TEM's and surface analysis systems (Agilent has a full range of ion pumps, which are key products for this application; please see ion pump section).
- Turbo molecular pumps are also a key component in modern focused-beam systems because they offer fast, oil-free air evacuation of large sample chambers (oil-free operation is a key requirement of many modern analysis applications such as semiconductor manufacturing). From Agilent's full range of turbo pumps, the focused-beam system designer can choose a pump size that offers the best chamber evacuation time with the best cost of ownership and compact size for use in limited space situations.
- Agilent has a full line of customized, low vibration turbo pumps for the most sensitive microscopy applications. Finally, Agilent has a full range of integrated pump controllers that offer the highest control flexibility with near zero electromagnetic noise generation.
- **Agilent offers a full range of application specific designed SEM turbo pumps including 80 l/s, 300 l/s, 550 l/s, 700 l/s and 1000 l/s speeds.**

All of Agilent's SEM turbo pumps designs can be verified in Agilent's application lab. Finally, each SEM turbo pump is tested in production before being shipped to the customer.

Mass Spectrometry

MS is our core business and has become a fundamental analytical tool in many industries. Thanks to advances in electronics, instrument designers can implement cost-effective, high-performance analytical power in a cost-effective, easy-to-use system.

These developments require advanced vacuum systems that are characterized by multi-chamber, high throughput designs on the high quality instruments.

These requirements, in turn, demand cost-effective, high performance vacuum pumps.

Agilent offers a full line of pumps and controllers that meet the most challenging vacuum requirements and are optimized for the specific requirements of modern mass spectrometry systems.



AGILENT TURBO PUMPS TYPICAL APPLICATIONS

Agilent can further customize its pumps by providing multi-inlet pumping systems that are compact and reliable. A few common application examples for mass spectrometry are listed below:

- **GC-MS**

Gas Chromatograph Mass Spectrometers typically use one vacuum chamber in relatively low gas load environments and an intermediate vacuum interface to analyze inorganic samples.

The Agilent Turbo-V 81 with printed circuit board controller (PCB) is a very cost-effective solution for this common analytical technique. The V 301 Navigator offers a compact, cost-effective solution for larger instrument designs.

- **LC-MS**

Liquid Chromatograph Mass Spectrometers typically include multi-chamber, high throughput vacuum systems.

Agilent's turbomolecular pumps are designed for high throughput operation with air cooling – an important benefit for maintaining a compact system. They are also available in several split flow versions to increase their utility and performance in this application.

The integrated controller provides a high level of control function in a small package.

- **ICP-MS**

Inductively Coupled Plasma-MS systems have a wide range of vacuum requirements. Many systems can use heavy carrier gases such as argon, while collision cell designs use helium.

Agilent turbopumps have a high efficiency motor and TwisTorr or MacroTorr drag stages to reduce heat production under gas load. These features allow to pump high levels of argon. Integrated or on board controllers assure compact package.

- **TOF**

Time Of Flight systems are becoming very important analytical tools in drug discovery and proteomics. Vacuum requirements vary, although small size is often an important consideration.

Agilent turbopump and controller package provides the TOF designer with a high degree of flexibility with regard to high throughput, efficient heat dissipation and compact size.



Industrial Vacuum Processing



Agilent Turbo-V 2K-G in Thin Film Deposition application.

- In a wide range of industries, from glass coating to medical equipment, manufacturers share a need for robust, reliable, production-friendly vacuum technologies.
- Focusing on the total cost of ownership, Agilent continues to deliver innovative vacuum solutions that maximize throughput, tolerate varying operating conditions, and simplify maintenance, helping to assure maximum uptime and efficiency.
- Turbo-V pumps, designed to withstand heavy industrial use, can handle high gas loads and will recover quickly from accidental air in-rushes.
- Agilent offers a comprehensive range of vacuum pumps and systems for industrial uses, including the new Turbo-V K-G Series, with truly integrated electronics embedded in the pump body.

Thin Film Deposition

- Glass coating equipment (architectural glass, automotive

TURBO PUMPS

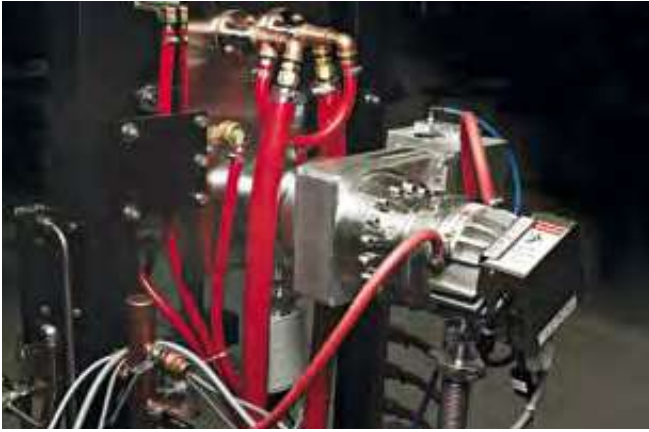

Courtesy Centorr.



Courtesy Optovac Vacuum Coating Systems.

- glass, flat panel display substrates)
- Thin film solar cells production (photo-voltaic)
- Optical data media (Compact Discs, Digital Versatile Discs, Magneto Optical Discs)
- Magnetic storage media (hard discs, read heads)
- Surface treatments used for Tribological and Wear coatings
- Functional and Decorative coatings, including Metallization
- Optical coating (ophthalmic, precision opto-electronics)
- Roll/Web coating on films or foils
- PVD and other Plasma Process systems requiring high gas load

Device Processing:

- TV & Monitor picture tube manufacture
- Evacuation of lamps (motorway lighting, beamers)
- X-Ray tubes & electron devices
- Medical accelerator tubes
- Lasers

General Industrial Processes:

- Vacuum furnaces / Brazing
- Electron beam welding

Dedicated Solutions for Thin Film Deposition

- In single chamber batch systems, multiple chamber systems, with load locks, or large inline continuous systems, Agilent has the right turbo pump for your process requirements. What really differentiates Agilent is the expertise of its applications, support and custom system design staff to integrate vacuum pumps into optimized vacuum solutions.

The Turbo-V K-G Series Systems

- Application-specific pumping solutions designed for thin film deposition equipment: the first fully integrated approach for maximum system productivity and uptime.
 - high pumping speed and high gas throughput
 - truly integrated power supply (Protection Class IP 54),



- resulting in compact size and ease of system integration
- capability to create differentiated partial pressures where needed
- maximum throughput capacity at stable operation pressure
- ceramic ball bearings, oil-free, contamination-free, no preventive maintenance, make the pump mountable in any position
- extremely low vibration and noise for sensitive applications
- water cooling (water compatibility up to 35 °C) allows long service life of electronic components
- permanent monitoring system integrated in the electronic device, and built-in self-diagnostics capability, in combination with our tailored service & support plans offers a unique solution for TFD applications.

AGILENT TURBO PUMPS MODELS

		Turbo-V 81 T		Turbo-V 81 M		TwisTorr 304 FS		Turbo-V 551 Navigator		Turbo-V 701 Navigator
Pump specification		DN 40	DN 63	DN 40	DN 63	DN 100	DN 160	DN 100	DN 160	DN 200
Pumping speed, l/s	Nitrogen	50	77	50	77	250	250	350	550	690
	Helium	56	65	56	65	255	255	450	600	620
	Hydrogen	46	50	46	50	220	220	450	510	510
	Argon					250	250			
Compression ratio	Nitrogen	7×10^8		3×10^8		$>1 \times 10^{11}$		$>1 \times 10^9$		1×10^9
	Helium	3×10^3		8×10^4		$>1 \times 10^8$		1×10^7		1×10^7
	Hydrogen	3×10^2		7×10^3		1.5×10^6		1×10^6		1×10^6
	Argon					$>1 \times 10^{11}$				
Base pressure, mbar	With recommended mechanical pump	5×10^{-9}		5×10^{-10}		$<1 \times 10^{-10}$		$<1 \times 10^{-10}$		$<1 \times 10^{-10}$
	With recommended dry pump	5×10^{-8}		5×10^{-9}				$<1 \times 10^{-10}$		$<1 \times 10^{-10}$
Startup time, min	< 1		< 1		< 3		< 5		< 5	
Rotational speed, rpm	80,000		80,000		60,000		42,000		42,000	
Recommended forepump	Mechanical pump	DS 42, DS 102		DS 42, DS 102		DS 102		DS 302		DS 302
	Dry pump	SH-110, IDP-3		SH-110, IDP-3		SH-110		IDP-15		IDP-15
Inlet flange, nominal diameter	Klamp flange, mm	40	–	40	–	–	–	–	–	–
	ConFlat, mm (inches OD)	35 (2.75)	63 (4.5)	35 (2.75)	63 (4.5)	100 (6)	160 (8)	100 (6)	160 (8)	200 (10)
	ISO clamp style, mm	–	63	–	63	100	160	–	160	200
	ISO-F bolted, mm	–	–	–	–	–	–	–	160-F bolted	200-F bolted
Foreline flange, nominal diameter	Klamp flange	NW16		NW16		NW16 (NW25 optional)		NW25		NW25
SEM version available on request	–		•		–		•		•	
Controllers	Rack controller	•		•		•		•		•
	Navigator on board contr.	•		•		•		•		•
	Integrated electronics	–		–		–		–		–
	PCB controller	•		•		–		–		–

*Rack version



TURBO PUMPS

Turbo-V 750 TwisTorr		Turbo-V 850 TwisTorr	Turbo-V 1001 Navigator			Turbo-V 2300 TwisTorr	Turbo-V 1K-G		Turbo-V 2K-G System	Turbo-V 3K-G System
DN 100*	DN 160	DN 200	DN 160	DN 200	DN 250	DN 250	DN 160	DN 200	DN 250	DN 250
370*	700	750	790	950	1,050	2,050	810	1,080	1,600	2,200
500*	680	690	820	870	900	1,800	950	1,150		
470*	580	590	860	900	920	1,500	680	730		
340*	680	700					750	1,040		
1×10^{11}	1×10^{11}		1×10^9			$>8 \times 10^8$	$>5 \times 10^7$		3×10^5	$>1 \times 10^7$
2×10^8	2×10^8		1×10^7			8×10^5	$>4 \times 10^4$			
2.5×10^6	2.5×10^6		1×10^6			4×10^4	1.5×10^4			
1×10^{11}	1×10^{11}						$>5 \times 10^8$			
$<1 \times 10^{-10}$	$<1 \times 10^{-10}$		$<1 \times 10^{-10}$			10^{-10}	$<1 \times 10^{-10}$		$<1 \times 10^{-8}$	$<1 \times 10^{-9}$
			$<1 \times 10^{-10}$				$<1 \times 10^{-10}$		$<1 \times 10^{-8}$	$<1 \times 10^{-9}$
< 6	< 3		< 4			< 6	< 5		< 7	< 6
50,000	50,000		38,000			33,300	45,660		33,000	31,800
DS 302 IDP-15	DS 302 IDP-15		DS 402 IDP-15			DS 602 TS600	$>20 \text{ m}^3/\text{h}$ $>36 \text{ m}^3/\text{h}$		$>40 \text{ m}^3/\text{h}$	$>60 \text{ m}^3/\text{h}$
-	-	-	-	-	-	-	-	-	-	-
100 (6)	160 (8)	200 (10)	-	200 (10)	-	250 (12)	-	-	-	-
-	160	200	160	200	250	-	-	-	-	-
-	160	200	-	200-F bolted	250-F bolted	250-F bolted	160-F	200-F	250-F bolted	250-F bolted
NW25	NW25 NW40		NW40			NW40	NW25	NW40	NW40	NW40
-	-		•			-	-	-	-	-
•	•		•			•	•	-	-	-
-	-		•			-	•	•	-	-
•	•		-			-	-	•	-	•
-	-		-			-	-	-	-	-

Turbo
Pumps



AGILENT TURBO PUMP MODELS

▶ Agilent Turbo-V 81-T

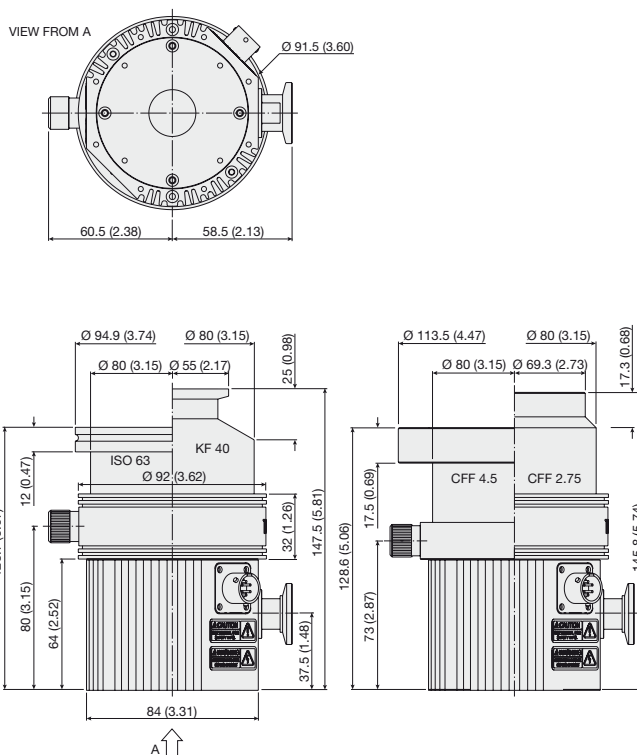

Dimensions: millimeters (inches)

Technical Specifications

Pumping speed (l/s)			
With CFF 4 ½" or ISO 63:	N ₂ : 77 l/s	He: 65 l/s	H ₂ : 50 l/s
With CFF 2 ¾" or KF 40:	N ₂ : 50 l/s	He: 56 l/s	H ₂ : 46 l/s
Compression ratio	N ₂ : >7 x 10 ⁶	He: 3 x 10 ³	H ₂ : 3 x 10 ²
Base pressure* (with recommended forepump)	5 x 10 ⁻⁹ mbar (3.8 x 10 ⁻⁹ Torr)		
Inlet flange	CFF 4 ½" O.D. CFF 2 ¾" O.D.	ISO 63 KF 40	
Foreline flange		KF 16 NW	
Rotational speed		1350 Hz (max)	
Start-up time		< 60 seconds	
Recommended forepump		Mechanical: Agilent DS 42 – DS 102 Dry pump: Agilent IDP-3, SH 110	
Operating position		Any	
Cooling requirements		Natural air convection Forced air or water optional	
Bakeout temperature		120 °C at inlet flange max. (CF flange) 80 °C at inlet flange max. (ISO flange)	
Vibration level (displacement)		<0.01 µm at inlet flange	
Weight kg (lbs)		ISO 63: 1.82 (4) CFF 4 ½": 2,68 (5.90)	

* According to standard DIN 28 428.

NOTE • The pump is available with On-board Navigator controller, ¼ Rack controller or PCB controller; for information on controllers see also following pages.

TURBO PUMPS

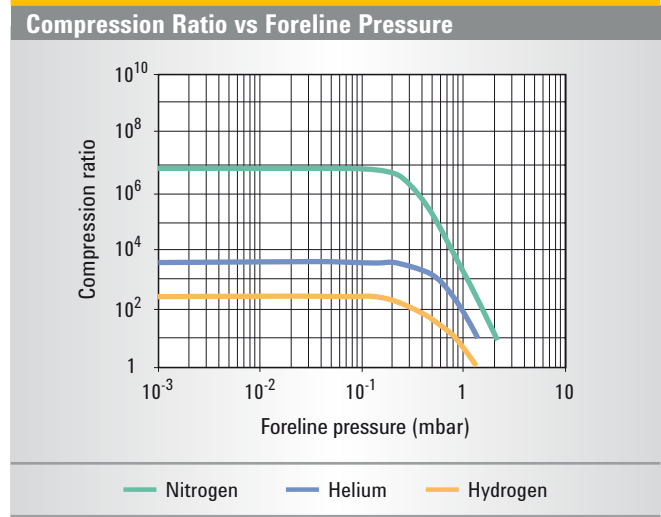
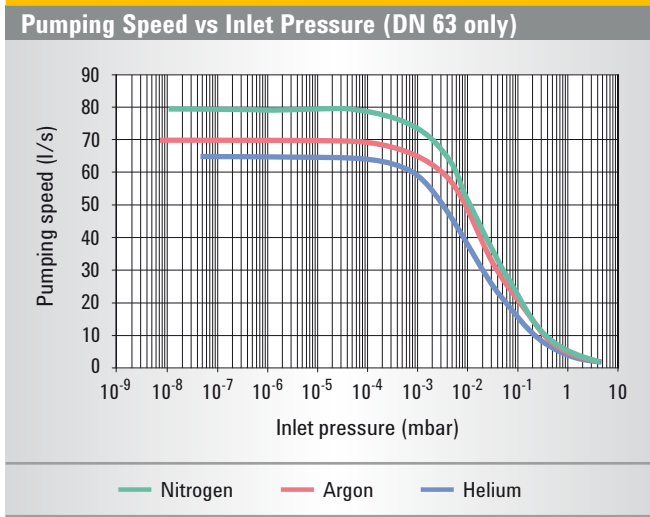

Ordering Information

Description	Weight kg (lbs)	Part Number
Pumps		
Turbo-V 81-T pump with ISO 63 inlet flange	1.82 (4.0)	9698905
Turbo-V 81-T pump with CF 4 ½" inlet flange	2.68 (5.9)	9698907
Turbo-V 81-T pump with KF 40 inlet flange	1.82 (4.0)	9698906
Turbo-V 81-T pump with CF 2 ¾" inlet flange	2.68 (5.9)	9698908
Controllers (See following pages for specifications)		
Turbo-V 81-AG Navigator controller 100-240 Vac	0.3 (0.66)	9698996
Turbo-V 81-AG Navigator controller 24 Vdc	0.3 (0.66)	9698995
Turbo-V 81-AG Rack controller base	1.7 (3.2)	9698988
Turbo-V 81-AG Rack controller RS232/485	1.7 (3.2)	9698989
Turbo-V 81-AG Rack controller Profibus	1.7 (3.2)	9698990
Turbo-V 81 PCB controller 24 Vdc	1.0 (2.2)	9699538
Pump Accessories		
Mains cable NEMA plug, 3 m long		9699958
Mains cable European plug, 3 m long		9699957
Serial cable and T-Plus Software		9699883
Inlet screen, KF 40		9699309
Inlet screen, CFF 4 ½" - ISO 63		9699300
Inlet screen, CFF 2 ¾"		9699328
Heater band 220 V		9699801
Heater band 120 V		9699802
Metallic water cooling kit		9699823
Plastic water cooling kit		9699824
Air cooling kit (0.5 m cable)		9699290
Air cooling kit extension cable (5 m)		9699940
Pump extension cable (3 m)		9699942
Vent valve N.O. 0.5 orifice (0.5 m cable)		9699844
Vent valve extension cable (5 m)		9699941
Vibration damper DN 63	0.5 (1.0)	9699375
Vibration damper CFF 4.5"	0.5 (1.0)	9699376
Vent flange KF 10	0.5 (1.0)	9699108
Active Gauges and cables	See Control Units section (pages 24-25)	
Recommended Forepump		
Mechanical pump DS 42	11.0 (24.0)	9499309
Mechanical pump DS 102	22.0 (48.0)	9499315
Dry scroll SH 110	19.0 (43.0)	SH01101 UNIV
Dry scroll IDP-3	9.5 (21.0)	Please see Dry Scroll Pump section

Turbo Pumps

AGILENT TURBO PUMP MODELS

▶ Agilent Turbo-V 81-M

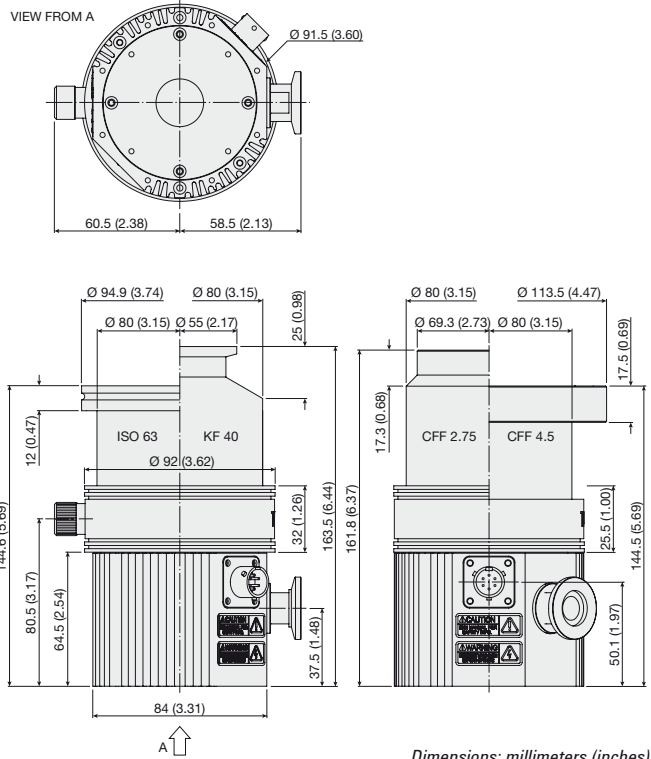

Dimensions: millimeters (inches)

Technical Specifications

Pumping speed (l/s)			
With CFF 4 ½" or ISO 63:	N ₂ : 77 l/s	He: 65 l/s	H ₂ : 50 l/s
With CFF 2 ¾" or KF 40:	N ₂ : 50 l/s	He: 56 l/s	H ₂ : 46 l/s
Compression ratio	N ₂ : 5 x 10 ⁸	He: 8 x 10 ⁴	H ₂ : 7 x 10 ³
Base pressure* (with recommended forepump)	5 x 10 ⁻¹⁰ mbar (3.8 x 10 ⁻¹⁰ Torr)		
Inlet flange	CFF 4 ½" O.D. CFF 2 ¾" O.D.	ISO 63 KF 40	
Foreline flange		KF 16 NW	
Rotational speed		1350 Hz (max)	
Start-up time		< 60 seconds	
Recommended forepump		Mechanical: Agilent DS 42 – DS 102 Dry pump: Agilent IDP-3, SH 110	
Operating position		Any	
Cooling requirements		Natural air convection Forced air or water optional	
Bakeout temperature		120 °C at inlet flange max. (CF flange) 80 °C at inlet flange max. (ISO flange)	
Vibration level (displacement)		<0.01 µm at inlet flange	
Weight (lbs)		ISO 63: 2 (4.4) CFF 4 ½": 2.98 (6.57)	

* According to standard DIN 28 428.

NOTE • The pump is available with On-board Navigator controller, ¼ Rack controller or PCB controller; for information on controllers see also following pages.

TURBO PUMPS

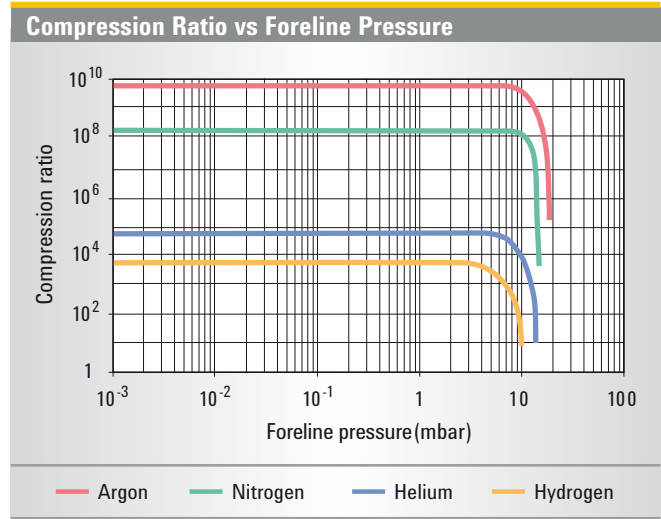
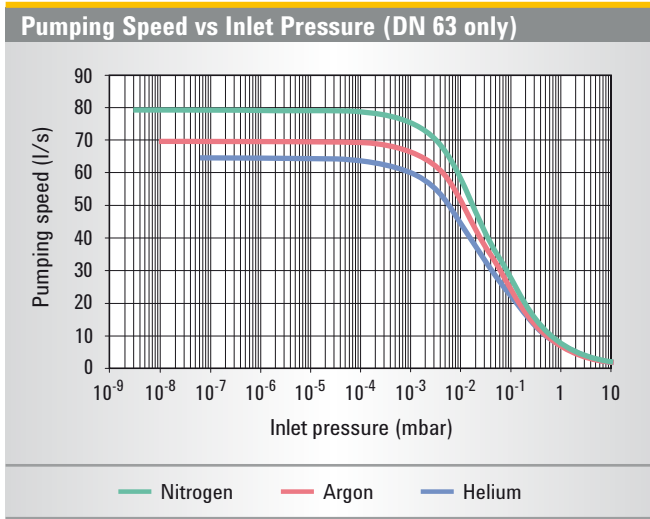

Ordering Information

Description	Weight kg (lbs)	Part Number
Pumps		
Turbo-V 81-M pump with ISO 63 inlet flange	2.0 (4.4)	9698901
Turbo-V 81-M pump with CFF 4 ½" inlet flange	2.98 (6.57)	9698903
Turbo-V 81-M pump with KF 40 inlet flange	2.0 (4.4)	9698902
Turbo-V 81-M pump with CFF 2 ¾" inlet flange	2.98 (6.57)	9698904
Controllers (See following pages for specifications)		
Turbo-V 81-AG Navigator controller 100-240 Vac	0.3 (0.66)	9698996
Turbo-V 81-AG Navigator controller 24 Vdc	0.3 (0.66)	9698995
Turbo-V 81-AG Rack controller base	1.7 (3.2)	9698988
Turbo-V 81-AG Rack controller RS232/485	1.7 (3.2)	9698989
Turbo-V 81-AG Rack controller Profibus	1.7 (3.2)	9698990
Turbo-V 81 PCB controller 24 Vdc	1.0 (2.2)	9699538
Pump Accessories		
Mains cable NEMA plug, 3 m long		9699958
Mains cable European plug, 3 m long		9699957
Serial cable and T-Plus Software		9699883
Inlet screen, KF 40		9699309
Inlet screen, CFF 4 ½" - ISO 63		9699300
Inlet screen, CFF 2 ¾"		9699328
Heater band 220 V		9699801
Heater band 120 V		9699802
Metallic water cooling kit		9699823
Plastic water cooling kit		9699824
Air cooling kit (0.5 m cable)		9699290
Air cooling kit extension cable (5 m)		9699940
Pump extension cable (3 m)		9699942
Vent valve N.O. 0.5 orifice (0.5 m cable)		9699844
Vent valve extension cable (5 m)		9699941
Vibration damper DN 63	0.5 (1.0)	9699375
Vibration damper CFF 4.5"	0.5 (1.0)	9699376
Vent flange KF 10	0.5 (1.0)	9699108
Active Gauges	See Control Units section (pages 24-25)	
Recommended Forepump		
Mechanical pump DS 42	11.0 (24.0)	9499309
Mechanical pump DS 102	22.0 (48.0)	9499315
Dry scroll SH 110	19.0 (43.0)	SH01101 UNIV
Dry scroll IDP-3	9.5 (21.0)	Please see Dry Scroll Pump section

Turbo Pumps

AGILENT TURBO PUMP CONTROLLERS

▶ Agilent Turbo-V 81-AG Navigator Controller

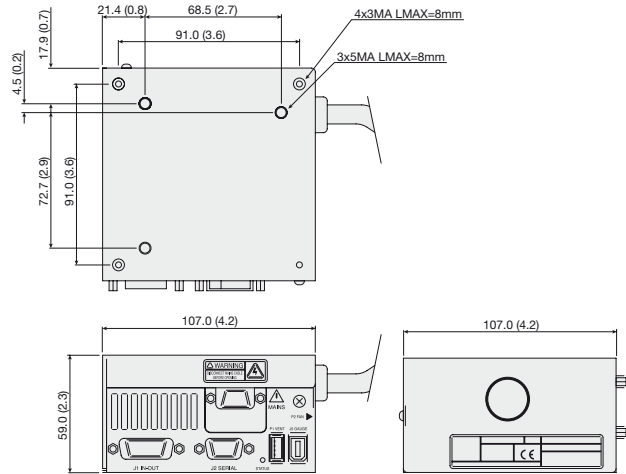

Dimensions: millimeters (inches)

The Turbo-V 81-AG Navigator controller is a solid-state frequency converter with the following features:

- Drives the pumps of the Turbo-V 81 family
- Powers the pump cooling fan
- Drives the vent valve
- Provides and acquires the pressure of the wide range gauge.
- Remote I/Os compatible with the previous version
- Navigator default serial compatible with the previous RS 232 and 485 version
- Able to operate with Active Gauges (Full Range Gauge FRG-700 and FRG-702)

The dedicated controller is a solid-state frequency converter which is driven by a single chip microcomputer and consists of two PCBs which include power supply and 3-phase output, analog and input/output section, microprocessor and digital

section. The power supply, together with the 3-phase output, converts the single phase AC mains supply or 24Vdc supply into a 3-phase, low voltage, medium frequency output which is required to power the pump. The controller can be operated by a remote host computer via the serial connection. A Windows-based software is available (optional).

The Turbo-V 81-AG Navigator controller can be mounted on board, on the bottom of the Turbo-V 81 Series pumps.

Ordering Information

Description	Weight kg (lbs)	Part Number
Controllers		
Turbo-V 81-AG Navigator controller*, 24 Vdc	0.3 (0.66)	9698995
Turbo-V 81-AG Navigator controller*, 100/240 Vac	0.3 (0.66)	9698996

* Order power cable separately

Accessories

Mains cable NEMA Plug, 3 m long	9699958
Mains cable European Plug, 3 m long	9699957
Serial cable and T-Plus Software	9699883
Air cooling kit (0.5 m)	9699290
Air cooling kit, extension cable (5 m)	9699940
Vent valve N.O. 0.5 mm orifice (0.7 m cable)	9699844
Vent valve extension cable (5 m, USB Type A - USB Type A)	9699941

Active Gauges

FRG-700 Pirani/IMG Combination Gauge, KF25	FRG700KF25
FRG-700 Pirani/IMG Combination Gauge, DN40 CF	FRG700CF35
FRG-702 Pirani/IMG Combination Gauge, KF25 All metal - bakeable	FRG702KF25
FRG-702 Pirani/IMG Combination Gauge, DN40 CF All metal - bakeable	FRG702CF35
Gauge connection cable to AG rack controller - 3 m	9699960
Gauge connection cable to AG rack controller - 5 m	9699961

Technical Specifications

Input voltages:	
Navigator controller, 24 Vdc	24 Vdc $\pm 10\%$
Navigator controller, 100/240 Vac	100 \div 240 Vac $\pm 10\%$
Input power:	
Navigator controller, 24 Vdc	80 W
Navigator controller, 100/240 Vac	180 VA
Input frequency:	
Navigator controller, 100/240 Vac	50 to 60 Hz $\pm 5\%$
Fuse	2 x T4 A 250 V
Output voltage	60 Vac
Output frequency	1350 Hz
Output power:	
Navigator controller, 24 Vdc	50 W
Navigator controller, 100/240 Vac	70 W (ramp), 50 W (Normal and Autotuning)
Operating temperature	+5 \div +45 °C 0 – 90% (Not condensing)
Storage temperature	-20 °C to +70 °C 0 – 95%

▶ Agilent Turbo-V 81-AG Rack Controller

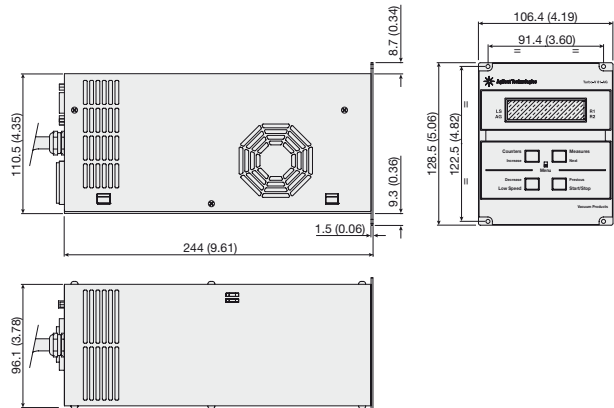

Dimensions: millimeters (inches)

The Turbo-V 81-AG Rack controller is a microprocessor-controlled frequency converter with new, enhanced features that allow greater control and communication capabilities. This compact, ¼ rack unit is designed for full worldwide compatibility, for vent valve control, active gauge pressure reading and pump operation parameters control, as well as for self diagnostic and protection features.

- **Universal Voltage**

Controller able to auto set according to the input voltage, providing flexibility for easy installation worldwide

- **RS-232/485 Communication Protocols and Profibus (Options)**

- Allows the pump to be interfaced with the system controls
- Enables the pump to be operated via PC with T-Plus software
- Helps development of own customer software

- **Stop Speed Reading (SSR)**

- Continues pump speed reading after the stop command
- Allows monitoring the pump in slow down ramp and shut down time

- **N.O. and N.C. Vent Valve Drive**

- Valve delay and opening time adjustable
- Vent valve driven by controller automatically or by serial line
- Opening time control through SSR function

Technical Specifications

Input	100 ÷ 240 Vac
	50/60 Hz
Maximum input power	210 VA
Output voltage	76 Vac
Output frequency	1,350 Hz
Nominal output power	100 W
Operating temperature	+5 °C to +45 °C
Storage temperature	-20 °C to +70 °C

- **Active Gauge Pressure Reading Capability**

- Able to operate with Active Gauges (Full Range Gauge FRG-700 and FRG-702)
- Provides accurate pressure measurements from atm down to 10⁻⁹ mbar
- Rack mounted control electronics no longer necessary, with simple +24 Vdc power connector
- Proven inverted magnetron design
- Rapid start even in high-vacuum conditions

Ordering Information

Description	Weight kg (lbs)	Part Number
Controller		
Turbo-V 81-AG Rack controller*	1.7 (3.2)	9698988
Turbo-V 81-AG with RS-232/485		9698989
Turbo-V 81-AG with Profibus		9698990

* Order power cable separately

Accessories

Air cooling kit (0.5 m cable)	9699290
Air cooling kit extension cable (5 m)	9699940
Vent valve N.O. 0.5 mm orifice (0.5 m cable)	9699844
Vent valve N.C. 0.5 mm orifice (0.5 m cable)	9699844M001
Vent valve extension cable (5 m)	9699941
Mains cable NEMA plug (3 m)	9699958
Mains cable european plug (3 m)	9699957
Pump extension cable (3 m)	9699942
Rack adapter for controller	9699191

Active Gauges

FRG-700 Pirani/IMG Combination Gauge, KF25	FRG700KF25
FRG-700 Pirani/IMG Combination Gauge, DN40 CF	FRG700CF35
FRG-702 Pirani/IMG Combination Gauge, KF25 All metal - bakeable	FRG702KF25
FRG-702 Pirani/IMG Combination Gauge, DN40 CF All metal - bakeable	FRG702CF35
Gauge connection cable to AG rack controller - 3 m	9699960
Gauge connection cable to AG rack controller - 5 m	9699961

AGILENT TURBO PUMP MODELS

▶ Agilent TwisTorr 304 FS

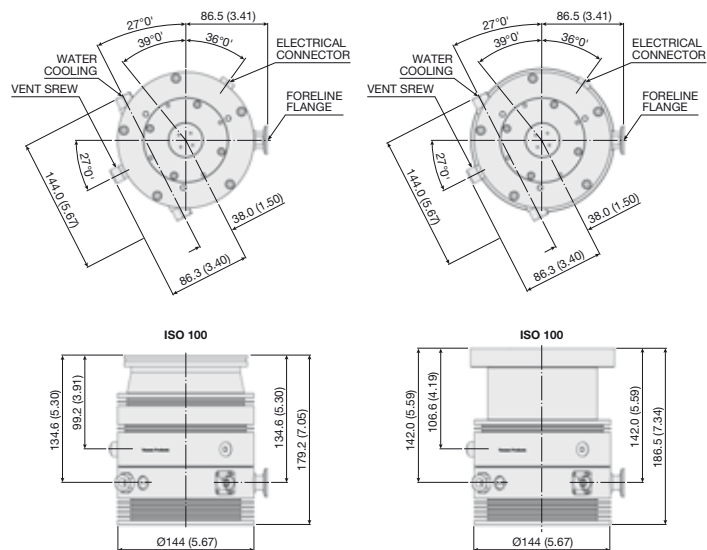

Dimensions: millimeters (inches)

Technical Specifications

Pumping speed (l/s)				
With CFF 6" or ISO 100:	N ₂ : 250 l/s	He: 255 l/s	H ₂ : 220 l/s	Ar: 250 l/s
With CFF 8" or ISO 160:	N ₂ : 280 l/s	He: 255 l/s	H ₂ : 220 l/s	Ar: 250 l/s
Gas throughput at full rotational speed (with recommended forepump)				
Ambient Temp. (25 °C)		N ₂ : 170 sccm	Ar: 110 sccm	
Water Temp. (25 °C, 50 l/h)		N ₂ : 170 sccm	Ar: 110 sccm	
Compression ratio & Foreline tolerance	N ₂ : > 1 x 10 ¹¹ N ₂ : >10 mbar	He: > 1 x 10 ⁸ He: >10 mbar	H ₂ : 1.5 x 10 ⁶ H ₂ : >4 mbar	Ar: > 1 x 10 ¹¹ Ar: >10 mbar
Base pressure with recommended forepump (5 m³/h)	< 1 x 10 ⁻¹⁰ mbar (< 1 x 10 ⁻¹⁰ Torr)			
Inlet flange	CFF 8" O.D.		ISO 160	
	CFF 6" O.D.		ISO 100	
Foreline flange	KF16 NW (KF25 - optional)			
Rotational speed	60000 rpm (1010 Hz driving frequency)			
Start-up time	< 3 minutes			
Recommended forepump	Mechanical: Agilent DS 102 Dry pump: Agilent SH-110			
Operating position	Any			
Operating ambient temperature	+5 °C to +35 °C			
Relative humidity of air	0 - 90 % (not condensing)			
Bakeout temperature	80 °C at inlet flange max. (ISO flange) 120 °C at inlet flange max. (CF flange)			
Lubricant	Permanent lubrication			
Cooling requirements	Forced air (5- 35 °C ambient temperature) Water (mandatory if ambient temperature > 35 °C)			
Coolant water	Minimum flow: 50 l/h (0.89 GPM)	Temperature: +15 °C to +30 °C	Pressure: 3 to 5 bar (45 to 75 psi)	
Noise pressure level	< 50 dB(A) at 1 meter			
Storage temperature	-40 °C to +70 °C			
Max altitude	3000 m			
Weight kg (lbs)	Pump ISO 100: 5.5 kg (12.3)	Pump CFF 6": 7.5 kg (16.5)	Pump ISO 160: 5.7 kg (12.6)	Pump CFF 8": 9.7 kg (20.9)

TURBO PUMPS

Pumping Speed vs Inlet Pressure

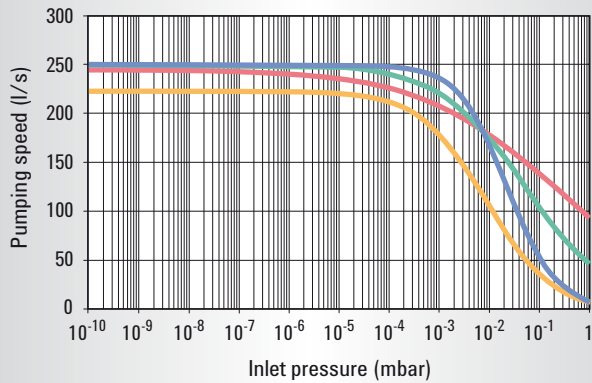

— Argon — Nitrogen — Helium — Hydrogen

Compression Ratio vs Foreline Pressure

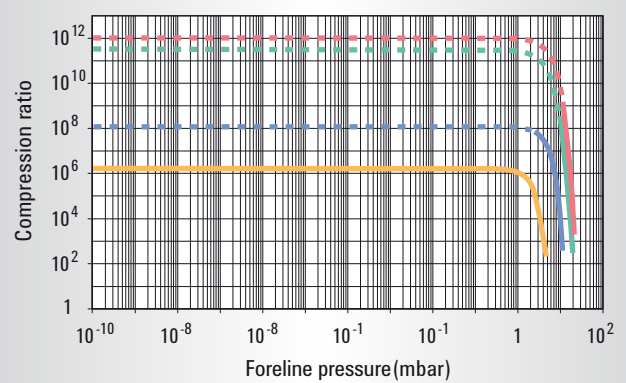

— Argon — Nitrogen — Helium — Hydrogen

Ordering Information

Pumps		Part Numbers
TwisTorr 304 FS ISO100	w/ water cooling	X3500-64000
TwisTorr 304 FS CFF 6"	w/ water cooling	X3500-64001
TwisTorr 304 FS ISO160	w/ water cooling	X3500-64002
TwisTorr 304 FS CFF 8"	w/ water cooling	X3500-64003
TwisTorr 304 FS ISO100	w/o water cooling	X3500-64004
TwisTorr 304 FS CFF 6"	w/o water cooling	X3500-64005
TwisTorr 304 FS ISO160	w/o water cooling	X3500-64006
TwisTorr 304 FS CFF 8"	w/o water cooling	X3500-64007
TwisTorr 304 FS ISO100 SF	w/ water cooling	X3500-64010

Controllers	Part Numbers
TwisTorr 304 FS on board controller 24 Vdc	X3507-64002
TwisTorr 304 FS on board controller 100-240 Vac	X3507-64003
TwisTorr 304 FS AG Rack controller with RS 232/485	X3506-64002
TwisTorr 304 FS AG Rack controller with Profibus	X3506-64003

Accessories	Part Numbers
Mains cable NEMA plug, 3 m long	9699958
Mains cable European plug, 3 m long	9699957
Serial cable and T-plus Software	9699883
Inlet Screen ISO100	X3500-68000
Inlet Screen CFF 6"	9699302
Inlet Screen ISO160	X3500-68001
Inlet Screen CFF 8"	9699304
Water cooling kit	9699337

Accessories	Part Numbers
Plastic water cooling kit	9699347
Air cooling kit for on board controller	X3500-68010
Fan extension cable for on board controller	9699949
Air cooling kit for rack AG controller	X3500-68011
Fan extension cable for rack AG controller	9699940
Bracket for on board controller side mounting	X3500-68012
Vibration isolator ISO 100	9699344
Vibration isolator CFF 6"	9699334
Vibration isolator ISO 160	9699345
Vibration isolator CFF 8"	9699335
Vibration isolator ISO 100 IDX	9699396
Vent flange, NW 10 KF / M8	9699108
Delay vent valve 1.2 mm orifice	X3505-68000
Delay vent valve 0.5 mm orifice	X3505-68001
Vent valve N.O. for rack AG controller (0.5 mm)	9699844
Vent valve for on-board controller (1.2 mm)	9699834
Vent valve for on-board controller (0.5 mm)	9699834M006
Purge valve 10 SCCM NW16KF - M12	9699239
Purge valve 10 SCCM ¼ Swagelok - M12	9699240
Purge valve 20 SCCM NW16KF - M12	9699241
Purge valve 20 SCCM ¼ Swagelok - M12	9699242
Purge valve 10 SCCM ¼ Swagelok - ¼ Swagelok	9699232
Purge valve 20 SCCM ¼ Swagelok - ¼ Swagelok	9699236
TwisTorr 304 foreline flange KF25	X3500-68002
Active Gauges	See TwisTorr 304 FS AG Rack controller (page 29)

AGILENT TURBO PUMP CONTROLLERS

▶ Agilent TwisTorr 304 FS on board Controller



120/220 V controller front panel

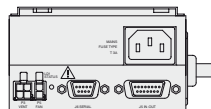

24 V controller front panel

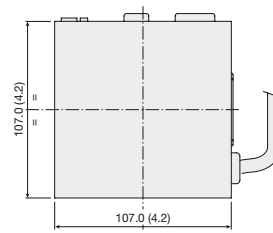
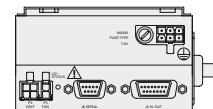

Dimensions: millimeters (inches)

The TwisTorr 304 FS on board controllers are microprocessor-controlled frequency converters, fully controllable through PC software, with self-diagnostic and protection features that ensure the highest degree of reliability.

They can be mounted on board, either on the bottom or on the side of the pump, offering outstanding flexibility and simplicity.

Technical Specifications

Input voltages:	
On board controller, 24 Vdc	24 Vdc \pm 10%
On board controller, 120/220 Vac	100/120/220/240 Volt, 1 phase, 50/60 Hz
Maximum input power:	
100-240 controller, 24 Vdc	200 W
100-240 controller, 120/220 Vac	300 VA
Output voltage	75 Vac, 3 phase
Output frequency	963 Hz
Nominal power	150 W
Start-up power	150 W
Operating temperature	0 °C to +40 °C
Storage temperature	20 °C to +70 °C

Ordering Information

Description	Weight kg (lbs)	Part Number
Controllers		
TwisTorr 304 FS on board controller*, 24 Vdc	0.3 (0.66)	X3507-64002
TwisTorr 304 FS on board controller*, 100-240 Vac	0.3 (0.66)	X3507-64003
<i>* Order power cable separately</i>		
Accessories		
Mains cable NEMA plug, 3 m long		9699958
Mains cable European plug, 3 m long		9699957
Serial cable and T-plus Software		9699883
Air cooling kit		X3500-68010
Fan extension cable		9699949
Bracket side mounting		X3500-68012
Vent valve (1.2 mm)		9699834
Vent valve (0.5 mm)		9699834M006

▶ Agilent TwisTorr 304 FS AG Rack Controller

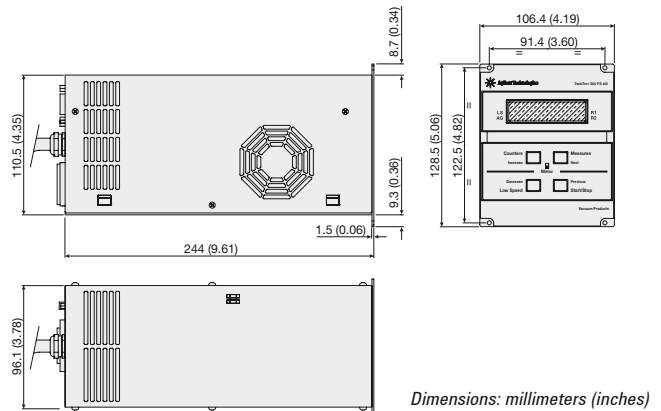

The TwisTorr 304 FS AG Rack controller is a microprocessor-controlled frequency converter with new, enhanced features that allow greater control and communication capabilities. This compact, ¼ rack unit is designed for full worldwide compatibility, for vent valve control, active gauge pressure reading and pump operation parameters control, as well as for self diagnostic and protection features.

- **Universal Voltage**

Controller able to auto set according to the input voltage, providing flexibility for easy installation worldwide

- **RS-232/485 Communication Protocols and Profibus (Options)**

- Allows the pump to be interfaced with the system controls
- Enables the pump to be operated via PC with T-Plus software
- Helps development of own customer software

- **Stop Speed Reading (SSR)**

- Continues pump speed reading after the stop command.
- Allows monitoring the pump in slow down ramp and shut down time

- **N.O. and N.C. Vent Valve Drive**

- Valve delay and opening time adjustable
- Vent valve driven by controller automatically or by serial line
- Opening time control through SSR function

Technical Specifications

Input	100 ÷ 240 Vac 50/60 Hz
Maximum input power	300 VA
Output voltage	75 Vac
Output frequency	963 Hz
Nominal output power	150 W
Operating temperature	+5 °C to +45 °C
Storage temperature	-20 °C to +70 °C

- **Active Gauge Pressure Reading Capability**

- Able to operate with Active Gauges (IM-500, Full Range Gauge FRG-700 and FRG-702)
- Provides accurate pressure measurements from atm down to 10⁻⁹ mbar
- Rack mounted control electronics no longer necessary, with simple +24 Vdc power connector
- Proven inverted magnetron design
- Rapid start even in high-vacuum conditions

Ordering Information

Description	Weight kg (lbs)	Part Number
Controller		
TwisTorr 304 FS AG Rack controller* with RS232/485	1.7 (3.2)	X3506-64002
TwisTorr 304 FS AG Rack controller* with Profibus	1.7 (3.2)	X3506-64003

* Order power cable separately

Accessories

Mains cable NEMA plug, 3 m long	9699958
Mains cable European plug, 3 m long	9699957
Serial cable and T-plus Software	9699883
Air cooling kit	X3500-68011
Fan extension cable	9699940
Vent valve N.O. (0.5 mm)	9699844

Active Gauges

PVG-500 Pirani, KF16	PVG500KF16
PVG-500 Pirani Tungsten filament, KF16	PVG500KF16S
FRG-700 Pirani/IMG Combination Gauge, KF25	FRG700KF25
FRG-700 Pirani/IMG Combination Gauge, DN40 CF	FRG700CF35
FRG-702 Pirani/IMG Combination Gauge, KF25 All metal - bakeable	FRG702KF25
FRG-702 Pirani/IMG Combination Gauge, DN40 CF All metal - bakeable	FRG702CF35
PCG-750 Pirani/CDG Combination Gauge (Tungsten), KF16	PCG750KF16
Gauge connection cable to AG rack controller - 3 m	9699960
Gauge connection cable to AG rack controller - 5 m	9699961

AGILENT TURBO PUMP MODELS

▶ Agilent Turbo-V 551 Navigator

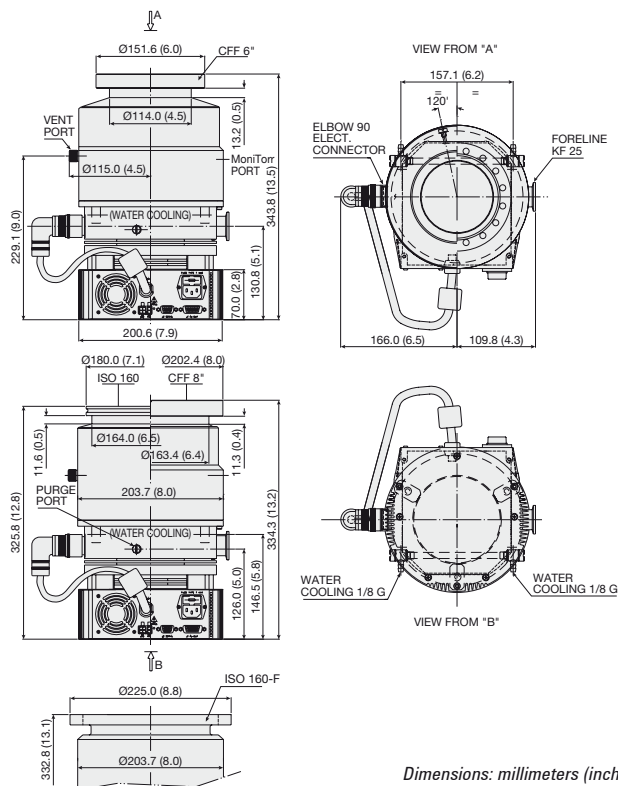

Dimensions: millimeters (inches)

Technical Specifications

Pumping speed (with inlet screen)			
CFF 6":	N ₂ : 350 l/s	He: 450 l/s	H ₂ : 450 l/s
CFF 8" or ISO 160:	N ₂ : 550 l/s	He: 600 l/s	H ₂ : 510 l/s
Compression ratio	N ₂ : 1 x 10 ⁹	He: 1 x 10 ⁷	H ₂ : 1 x 10 ⁶
Base pressure* (with minimum recommended forepump)	<1 x 10 ⁻¹⁰ mbar (< 1 x 10 ⁻¹⁰ Torr)		
Inlet flange	CFF 6"	ISO 160	
	CFF 8"	ISO 160-F bolted	
Foreline flange	KF 25		
Rotational speed	42,000 rpm		
Start-up time	<5 minutes		
Recommended forepump	Mechanical: Agilent DS 302 Dry scroll: Agilent TS300, IDP-15		
Operating position	Any		
Cooling requirements	Natural air convection Water optional (use water with electrical conductivity ≤ 500 μS/cm)		
Bakeout temperature	120 °C at inlet flange max. (CF flange) 80 °C at inlet flange max. (ISO flange)		
Vibration level (displacement)	<0.01 μm at inlet flange		
Weight kg (lbs)	ISO flange 19.4 (43.0) CF flange 23.4 (51.6) CF and ISO bolted flange 23.4 (51.6)		

* According to PNEUROP 5608.

SEM version available on request

TURBO PUMPS

Pumping Speed vs Inlet Pressure (DN 160 only)

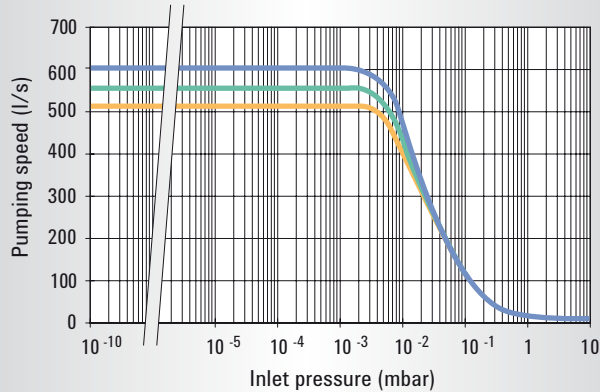

— Nitrogen — Helium — Hydrogen

Compression Ratio vs Foreline Pressure

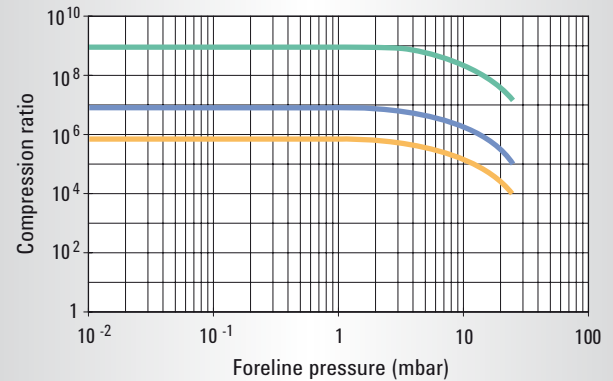

— Nitrogen — Helium — Hydrogen

Ordering Information

Description	Weight kg (lbs)	Part Number
Complete Systems		
Turbo-V 551 Navigator complete system, ISO 160 flange	19.4 (43.0)	9698832
Turbo-V 551 Navigator complete system, ISO 160-F bolted flange	23.4 (51.6)	9698842
Turbo-V 551 Navigator complete system, 6" CF flange	23.4 (51.6)	9698835
Turbo-V 551 Navigator complete system, 8" CF flange	23.4 (51.6)	9698833
<i>Complete system includes: Pump, Inlet screen, Controller mounted on the bottom, 2 Mains cables (NEMA plug and European plug).</i>		
Pumps		
Turbo-V 551 Navigator pump, ISO 160 flange	16.0 (35.0)	9698922
Turbo-V 551 Navigator pump, ISO 160-F bolted flange	22.0 (49.0)	9698944
Turbo-V 551 Navigator pump, 6" CF flange	22.0 (49.0)	9698925
Turbo-V 551 Navigator pump, 8" CF flange	22.0 (49.0)	9698923
Controllers		
Turbo-V 551 Navigator controller 120/220 V - 50/60 Hz	3.0 (6.0)	9698976
Turbo-V 551 Rack controller, 100-240 V	15.7 (35.0)	X3501-64001

Description	Weight kg (lbs)	Part Number
Accessories		
Mains cable NEMA plug, 3 m long		9699958
Mains cable European plug, 3 m long		9699957
Serial cable and T-plus Software <i>(previous release Navigator 2.2 included in the CD)</i>		9699883
Inlet screen DN 100		9699302
Inlet screen DN 160		9699304
Water cooling kit		9699337
Plastic water cooling kit		9699347
Air cooling kit for use with Navigator controller		9699339
Air cooling kit for use with standard rack controller, 24 V		X3501-68001
Bracket for Navigator controller side mouting		9699349
Vibration damper CFF 6"	3.0 (7.0)	9699334
Vibration damper ISO 160	4.0 (9.0)	9699345
Vibration damper CFF 8"	4.0 (9.0)	9699335
Vent flange, NW 10 KF / M8		9699108
Vent valve kit for standard rack controller, 24 V		X3501-68002
Vent valve for Navigator controller		9699834
Purge valve 10 SCCM NW16KF - M12		9699239
Purge valve 10 SCCM ¼ Swagelok - M12		9699240

AGILENT TURBO PUMP MODELS

▶ Agilent Turbo-V 701 Navigator

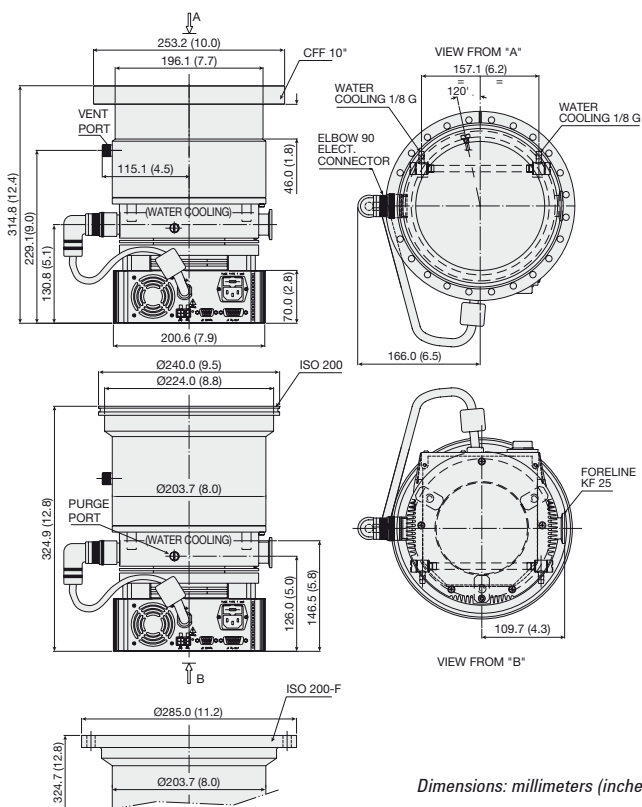

Dimensions: millimeters (inches)

Technical Specifications

Pumping speed (with inlet screen) CFF 10" or ISO 200:	N ₂ : 690 l/s	He: 620 l/s	H ₂ : 510 l/s
Compression ratio	N ₂ : 1 x 10 ⁹	He: 1 x 10 ⁷	H ₂ : 1 x 10 ⁶
Base pressure* (with minimum recommended forepump)	<1 x 10 ⁻¹⁰ mbar (< 1 x 10 ⁻¹⁰ Torr)		
Inlet flange	CFF 10"	ISO 200	ISO 200-F bolted
Foreline flange	KF 25		
Rotational speed	42,000 rpm		
Start-up time	<5 minutes		
Recommended forepump	Mechanical: Agilent DS 402 Dry scroll: Agilent TS300, IDP-15		
Operating position	Any		
Cooling requirements	Natural air convection Water optional (use water with electrical conductivity ≤ 500 μS/cm)		
Bakeout temperature	120 °C at inlet flange max. (CF flange) 80 °C at inlet flange max. (ISO flange)		
Vibration level (displacement)	<0.01 μm at inlet flange		
Weight kg (lbs)	ISO flange 19.4 (43.0) CF flange 25.5 (54.2) CF and ISO bolted flange 25.5 (54.2)		

* According to PNEUROP 5608.

SEM version available on request

TURBO PUMPS

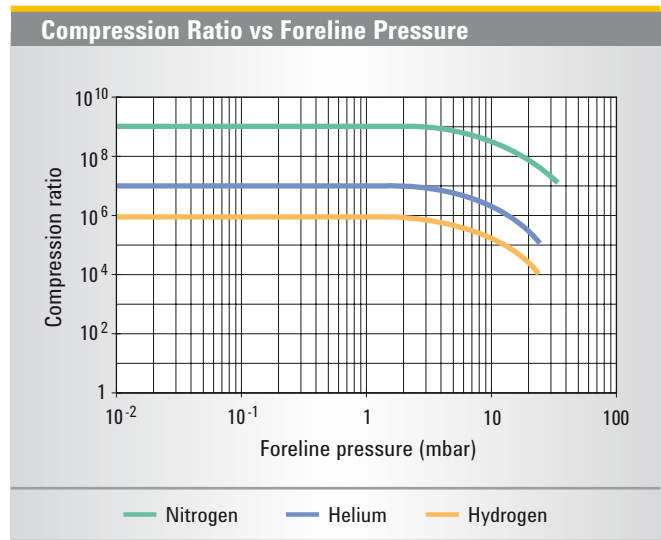
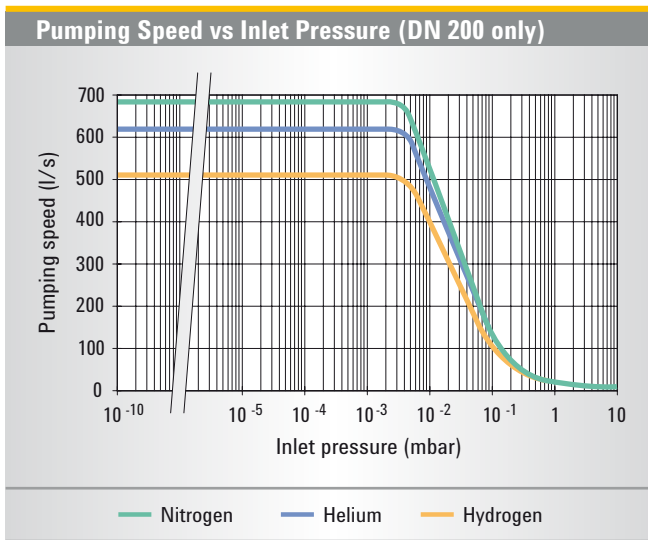

Ordering Information

Description	Weight kg (lbs)	Part Number
Complete Systems		
Turbo-V 701 Navigator complete system, ISO 200 flange	19.0 (43.0)	9698836
Turbo-V 701 Navigator complete system, ISO 200-F bolted flange	25.0 (56.0)	9698843
Turbo-V 701 Navigator complete system, 10" CF flange	25.0 (56.0)	9698837
<i>Complete system includes: Pump, Inlet screen, Controller mounted on the bottom, 2 Mains cables (NEMA plug and European plug).</i>		
Pumps		
Turbo-V 701 Navigator pump, ISO 200	16.0 (35.0)	9698926
Turbo-V 701 Navigator pump, ISO 200-F bolted	22.0 (49.0)	9698945
Turbo-V 701 Navigator pump, 10" CFF	22.0 (49.0)	9698927
Controllers		
Turbo-V 701 Navigator controller 120/220 V - 50/60 Hz	3.0 (6.0)	9698977
Turbo-V 701 Rack controller, 100-240 V	16.0 (35.0)	X3501-64002
Accessories		
Mains cable NEMA plug, 3 m long		9699958
Mains cable European plug, 3 m long		9699957
Serial cable and T-plus Software (previous release Navigator 2.2 included in the CD)		9699883
Inlet screen DN 200		9699316
Water cooling kit		9699337
Plastic water cooling kit		9699347
Air cooling kit for use with Navigator controller		9699339
Air cooling kit for use with standard rack controller, 24 V		X3501-68001
Bracket for Navigator controller side mounting		9699349
Vibration damper, ISO 200	5.0 (10.0)	9699346
Vibration damper, CFF 10"	5.0 (10.0)	9699336
Vent flange, NW 10 KF / M8		9699108
Vent valve kit for standard rack controller		X3501-68002
Vent valve for Navigator controller		9699834
Purge valve 10 SCCM NW16KF – M12		9699239
Purge valve 10 SCCM ¼ Swagelok – M12		9699240

AGILENT TURBO PUMP CONTROLLERS

▶ Agilent Turbo-V 551 and 701 Navigator Controllers

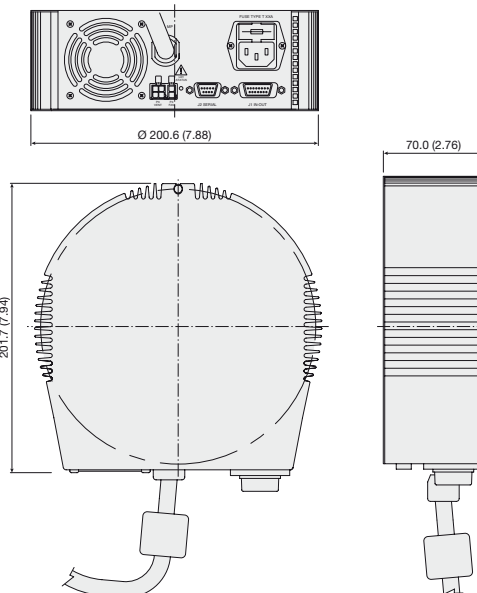

Dimensions: millimeters (inches)

The Turbo-V 551 and 701 Navigator controllers are microprocessor-controlled frequency converters, fully controllable through PC software, with self-diagnostic and protection features that ensure the highest degree of reliability. They can be mounted on board, either on the bottom or on the side of the pump, offering outstanding flexibility and simplicity.

Technical Specifications

Input voltages	100/120/220/240 VAC 50/60 Hz, 1 ph
Maximum input power	640 VA
Output voltage	54 VAC, 3 ph
Output frequency	714 Hz
Operating temperature	0 °C to +40 °C
Storage temperature	-20 °C to +70 °C

Ordering Information

Description	Weight kg (lbs)	Part Number
Controllers		
Turbo-V551 Navigator controller 120/220 V - 50/60 Hz	3.0 (6.0)	9698976
Turbo-V701 Navigator controller 120/220 V - 50/60 Hz	3.0 (6.0)	9698977
Accessories		
Mains cable NEMA plug, 3 m long		9699958
Mains cable European plug, 3 m long		9699957
Serial cable and T-plus Software <i>(previous release Navigator 2.2 included in the CD)</i>		9699883
External "TMP Profibus gateway"		9699261

TURBO PUMPS

▶ Agilent Turbo-V 551 and 701 Rack Controllers

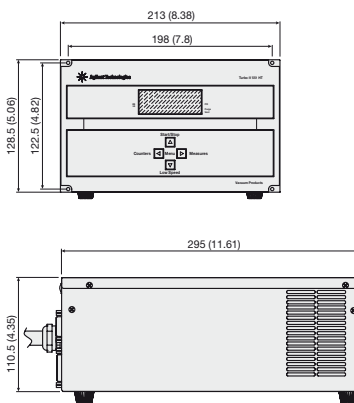

Dimensions: millimeters (inches)

These controllers are microprocessor-controlled frequency converters with self diagnostic and protection features that ensure the highest degree of reliability. The compact, ½ rack unit has a multifunction alphanumeric display for pump status and error code diagnostics. The front panel has a two-line dot matrix LCD display with back lighting. It displays rotational speed as the pump starts up and indicates when full speed is reached. At any time during the operation of the pump, the speed, current, power, and bearing temperature can be displayed. Additionally, the microprocessor acts as a pump

cycle log, and can display the number of vacuum cycles, the cycle time for the current cycle, and the total operating hours on the pump. Remote operation can be accomplished with logic level contact closures and with optional computer interfaces.

PCB controllers are available. Please contact Agilent for details.

Technical Specifications

Input voltages	100-240 V 1 ph, 50/60 Hz
Maximum input power	800 VA
Output frequency	700 Hz
Maximum output power*	
V 501:	320 W
V 701:	350 W
Startup power	430 W
Operating temperature	+5 °C to +45 °C
Storage temperature	-20 °C to +70 °C

* Data valid for nitrogen.

Ordering Information

Description	Weight kg (lbs)	Part Number
Controllers		
Turbo-V 551 Rack controller with RS 232/485, 120-220 V	15.7 (35.0)	X3501-64001
Turbo-V 701 Rack controller with RS 232/485, 120-220 V	15.7 (35.0)	X3501-64002
Accessories		
J1 input mating connector		9699853
P6 and P7 mating plug		9699854
Mains cable (European plug, 3 m long)		9699957
Mains cable (American plug, 120 V, 3 m long)		9699958
Options		
P2 output mating connector		9699852
Rack adapter for controller		9699191
Controller to pump extension cable (3 m extension) for Turbo-V 551, 701	1.0 (2.0)	9699948
Controller to pump extension cable (5 m extension) for Turbo-V 551, 701	2.0 (4.0)	9699948M001
Controller to pump extension cable (20 m extension) for Turbo-V 551, 701	4.0 (8.0)	9699948M002

AGILENT TURBO PUMP MODELS

▶ Agilent Turbo-V 750 TwisTorr System

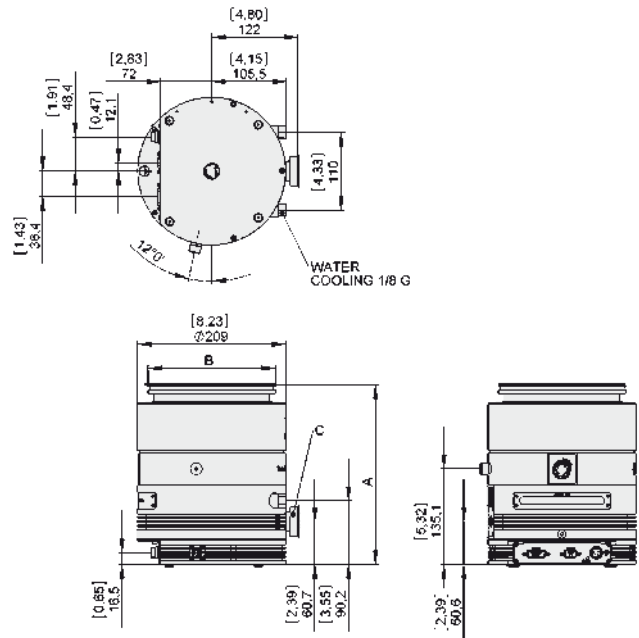

Dimensions: millimeters (inches)

Technical Specifications

Vacuum Performances	
Pumping speed for N ₂ (*)	N ₂ = 700 l/s
Pumping speed for Ar (*)	Ar = 680 l/s
Pumping speed for He (*)	He = 680 l/s
Pumping speed for H ₂ (*)	H ₂ = 580 l/s
Compression ratio for N ₂	N ₂ = 1 x 10 ¹¹
Compression ratio for Ar	Ar > 1 x 10 ¹¹
Compression ratio for He	He = 2 x 10 ⁸
Compression ratio for H ₂	H ₂ = 2.5 x 10 ⁶
Base pressure*	<1 x 10 ⁻¹⁰ mbar
<i>(with minimum recommended forepump)</i>	
Max foreline pressure for N ₂	6 mbar
Inlet Flange size	ISO 160K, CFF 8", ISO 160F
Foreline flange	KF25
Other	
Rotational speed	Selectable from 350 Hz to 825 Hz
Start up time (90% of full speed)	< 3 min
Recommended forepump	PTS300, DS302, IDP-15
Operational position	Any
Cooling options	Forced Air (up to 35 °C ambient temp.) Water (corrosion resistant loop)
Max flange temperature during bake-out (no gas flow)	120 °C (CFF), 80 °C (ISO)
Noise level (pump at full speed, no load)	FAN off < 52 dB(A) at 1 meter FAN on < 55 dB(A) at 1 meter
Storage temperature	-20 °C to +70 °C
Certifications	CE, C, CSA_US, ROHS compliant
Purge and Vent	Standard Purge & Vent ports Automated Purge/Vent device (accessory)
Weight (with integrated controller)	ISO 160 K = 15.9 kg (34.9 lbs) CFF 8" = 22.5 kg (49.4 lbs)

(*): According to Pneuop 5608 III, TS 300 PRIMARY PUMP, NO INLET SCREEN

Model	Inlet Flange	A	B	C
9698813	ISO 160K	253.8 (9.99)	Ø 179.9 (7.08)	KF 25
9698814	CFF 8"	264.2 (10.40)	Ø 202.4 (7.97)	KF 25
9698818	ISO 160F	262.7 (10.34)	Ø 225 (8.86)	KF 25

Controller Specifications

Controller type	Fully integrated electronics
Motor control mode	Field Oriented Control (FOC)
Input voltage	48 Vdc (± 10%)
Maximum input power	450 W
Maximum output power	400 W (pump ramp-up) 300 W (water cooling) 200 W (forced air cooling)
Input voltage for power supply	100 – 240 Vac (± 10%)
Input frequency for power supply	50 – 60 Hz
Maximum input power for power supply	550 VA
Maximum operating power for power supply	450 W
Interface	Navigator standard remote I/O RS 232, RS 485 serial Can accept Profibus external device
Protection category	IP 54
Data Logger	Standard
Stop speed reading	Standard
Automated Purge/Vent device control	Standard
Leak Detector Mode function	Standard

TURBO PUMPS

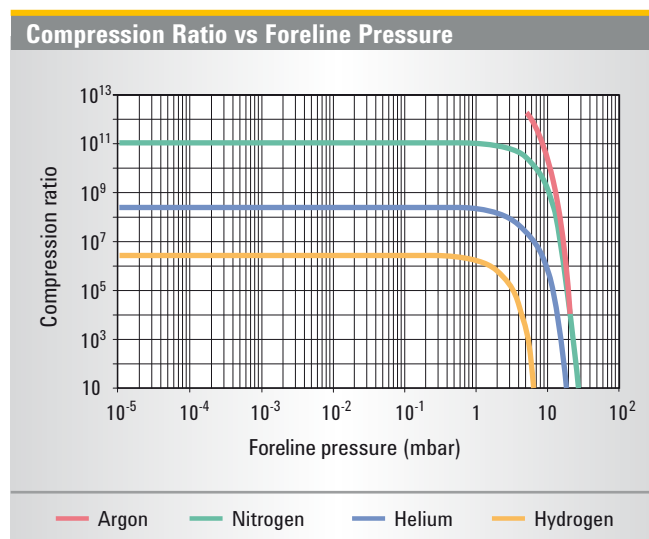
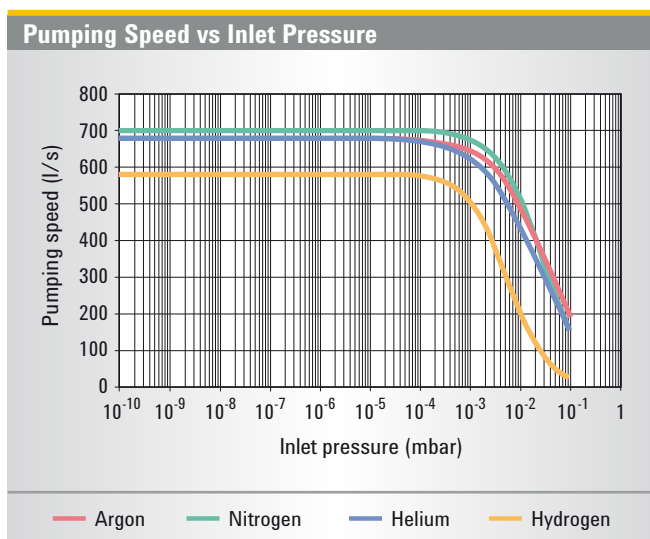

Ordering Information

Pumping Systems*	Part Number
Agilent Turbo-V 750 ISO 160K On-Board	9698813
Agilent Turbo-V 750 CFF 8" On-Board	9698814
Agilent Turbo-V 750 ISO 160F On-Board	9698818

(*): Pumping Systems include pump with integrated controller 48 Vdc, inlet screen, 9 and 15 pin mating connectors IP-54.

Accessories

Turbo-V 750/850 TwisTorr Power Supply (5 m pump cable)*	9696521
Mains cable NEMA Plug, 3 m long	9699958
Mains cable European Plug, 3 m long	9699957
Turbo-V 750/850 TwisTorr Purge/Vent Device N.C. (0.2 m cable)	9696502
Turbo-V 750/850 TwisTorr Fan (0.2 m cable)	9696503
T-Plus software and serial cable	9699883
Inlet screen ISO 160 and CFF 8"	9699304
Water cooling kit (plastic model)	9699347
Water cooling kit (metallic model)	9699337
Water kit, Hose tail 1/8G	9699828
Vibration isolator, ISO 160	9699345
Vibration isolator, CFF 8"	9699335
Vent flange, NW 10 KF / M8	9699108
Purge valve with KF16-M12 10 SCCM	9699239
Purge valve with 7/16-M12 10 SCCM	9699240
Purge valve KF16-M12 20 SCCM	9699241
Purge valve 7/16-M12 20 SCCM	9699242
External Profibus TMP gateway	9699261
Forepump DS 302, with 1 ph., universal motor	9499325
TriScroll Dry Vacuum Pump PTS 300 single phase, US cord	PTS03001UNIV
TriScroll Dry Vacuum Pump PTS 300 single phase, Euro cord	PTS03001UNIVEU
TriScroll Dry Vacuum Pump PTS 300 single phase, UK cord	PTS03001UNIVUK
TriScroll Dry Vacuum Pump PTS 300 3 phase	PTS03003UNIV
IDP-15 Dry Scroll Pump, Std	X3815-64000
IDP-15 Dry Scroll Pump, Std with inlet valve	X3815-64010

(*) Power Supply is necessary to provide 48 VDC to the on board electronics.

AGILENT TURBO PUMP MODELS

▶ Agilent Turbo-V 750 TwisTorr Rack

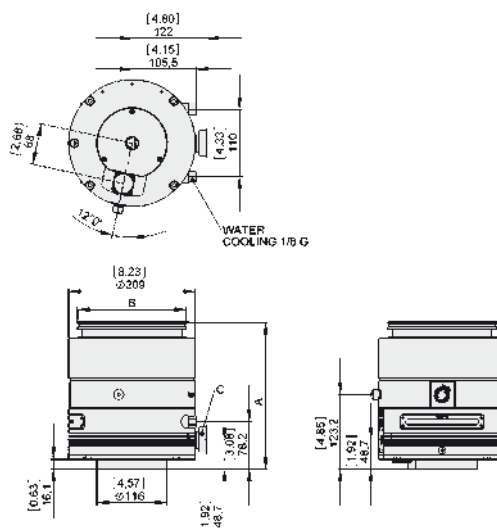

Model	Inlet Flange	A	B	C
9696013	ISO 160K	241.8 (9.52)	Ø 179.9 (7.08)	KF 25
9696014	CFF 8"	252.2 (9.93)	Ø 202.4 (7.97)	KF 25
9696017	CFF 6"	258.7 (10.19)	Ø 151.6 (5.97)	KF 25
9696018	ISO 160F	252.7 (9.95)	Ø 225 (8.86)	KF 25

Technical Specifications

Vacuum Performances	ISO 160/CFF 8"	CFF 6"
Pumping speed for N ₂ (*)	N ₂ = 700 l/s	N ₂ = 370 l/s
Pumping speed for Ar (*)	Ar = 680 l/s	Ar = 340 l/s
Pumping speed for He (*)	He = 680 l/s	He = 500 l/s
Pumping speed for H ₂ (*)	H ₂ = 580 l/s	H ₂ = 470 l/s
Compression ratio for N ₂	N ₂ = 1 x 10 ¹¹	
Compression ratio for Ar	Ar > 1 x 10 ¹¹	
Compression ratio for He	He = 2 x 10 ⁸	
Compression ratio for H ₂	H ₂ = 2.5 x 10 ⁶	
Base pressure* (with minimum recommended forepump)	<1 x 10 ⁻¹⁰ mbar	
Max foreline pressure for N ₂	6 mbar	
Inlet Flange size	ISO 160K, CFF 8", ISO 160F	
Foreline flange	KF25	
Other		
Rotational speed	Selectable from 350 Hz to 825 Hz	
Start up time (90% of full speed)	< 6 min (with 5 m pump cable length)	
Recommended forepump	PTS300, DS302, IDP-15	
Operational position	Any	
Cooling options	Forced Air (up to 35 °C ambient temp.) Water (corrosion resistant loop)	
Max flange temperature during bake-out (no gas flow)	120 °C (CFF), 80 °C (ISO)	
Noise level (pump at full speed, no load)	FAN off < 52 dB(A) at 1 meter FAN on < 55 dB(A) at 1 meter	
Storage temperature	-20 °C to +70 °C	
Certifications	CE, C, CSA, US, ROHS compliant	
Purge and Vent	Standard Purge & Vent ports Automated Purge/Vent device (accessory)	
Weight	ISO 160 K = 15.7 kg (34.6 lbs) CFF 8" = 22.3 kg (49.2 lbs)	

(*): According to Pneuport 5608 III, TS 300 PRIMARY PUMP, NO INLET SCREEN

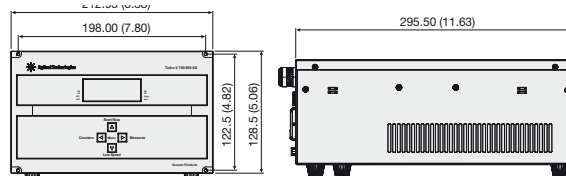

Dimensions: millimeters (inches)

Controller Specifications	Controller Models 9699525-9699526	Controller Model X3501-64000
Input voltage	100 – 240 Vac (± 10%)	100 – 240 Vac (± 10%)
Input frequency	50 – 60 Hz	50 – 60 Hz
Maximum input power	600 VA	800 VA
Maximum output power		
pump ramp-up	320 W	420 W
water cooling	300 W	300 W
forced air cooling	200 W	200 W
<i>(Specification with standard cable length 5 mt)</i>		
Interface	Navigator standard remote I/O RS 232, RS 485 serial Can accept Internal Profibus board	Navigator standard remote I/O RS 232
Protection category	IP 20	IP 20
Data Logger	Standard	No
Stop speed reading	Standard	Yes
Active stop	Standard	Yes
Automated Purge/Vent device control	Standard	Yes
External gauge readout	2 ports compatible with Agilent gauges	No
Primary pump control	Pilot 2 external configurable relays (48 Vdc (± 10%) - 250 mA MAX)	Yes

TURBO PUMPS

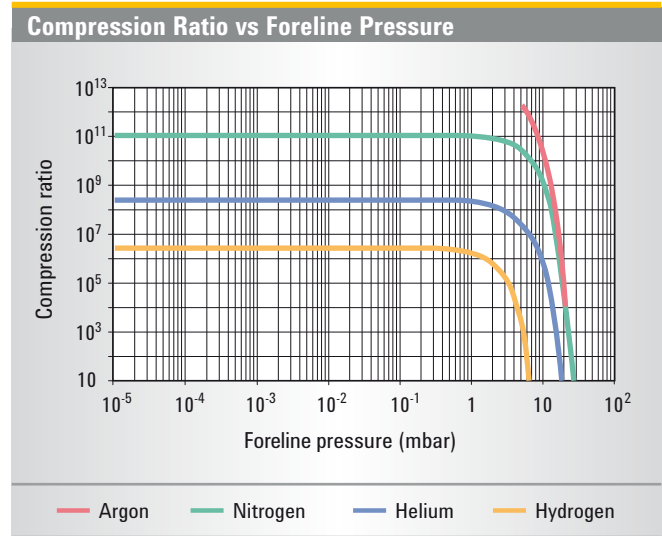
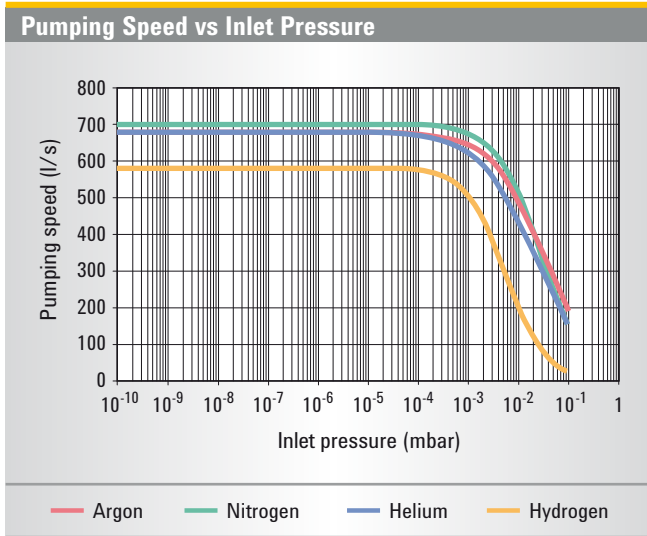

Ordering Information

Pumps	Part Number
Agilent Turbo-V 750 ISO 160K Rack	9696013
Agilent Turbo-V 750 CFF 8" Rack	9696014
Agilent Turbo-V 750 CFF 6" Rack	9696017
Agilent Turbo-V 750 ISO 160F Rack	9696018

Controllers	Part Number
Agilent Turbo-V 750/850-AG Rack CNT (5 m pump cable incl. - max TMP cable 25 m)	9699525
Agilent Turbo-V 750/850-AG Rack CNT Profibus (5 m pump cable incl. - max TMP cable 25 m)	9699526
Agilent Turbo-V 750/850-AG Rack CNT Profibus (5 m pump cable incl. - max TMP cable 60 m)	X3501-64000

General Accessories	Part Number
Mains cable NEMA Plug, 3 m long	9699958
Mains cable European Plug, 3 m long	9699957
T-Plus software and serial cable	9699883
Inlet screen ISO 160 and CFF 8"	9699304
Inlet screen CFF 6"	9699302
Water cooling kit (plastic model)	9699347
Water cooling kit (metallic model)	9699337
Water kit, Hose tail 1/8G	9699828
Vibration isolator, ISO 160	9699345
Vibration isolator, CFF 6"	9699334
Vibration isolator, CFF 8"	9699335
Vent flange, NW 10 KF / M8	9699108
Purge valve with KF16-M12 10 SCCM	9699239
Purge valve with 7/16-M12 10 SCCM	9699240
Purge valve KF16-M12 20 SCCM	9699241
Purge valve 7/16-M12 20 SCCM	9699242

Controller Accessories (9699525-9699526)	Part Number
Turbo-V 750/850 TwisTorr Purge/Vent Device N.C. (0.2 m cable)	9696502
Turbo-V 750/850 TwisTorr Fan (0.2 m cable)	9696503
Turbo-V 750/850 TwisTorr Purge/Vent 5 m extension cable	9696504
Turbo-V 750/850 TwisTorr Purge/Vent 15 m extension cable	9696505
Turbo-V 750/850 TwisTorr Purge/Vent 25 m extension cable	9696506
Turbo-V 750/850 TwisTorr Fan 5 m extension cable	9696514
Turbo-V 750/850 TwisTorr Fan 15 m extension cable	9696515
Turbo-V 750/850 TwisTorr Fan 25 m extension cable	9696516
Turbo-V 750/850 TwisTorr 10 m pump extension cable	9696518
Turbo-V 750/850 TwisTorr 20 m pump extension cable	9696519

Controller Accessories (X3501-64000)	Part Number
Air cooling kit (24 V)	X3501-68000
Vent valve extension cable - 5 m	X3501-68004
Turbo-V 750/850 TwisTorr 3 m pump extension cable	9699948
Turbo-V 750/850 TwisTorr 5 m pump extension cable	9699948M001
Turbo-V 750/850 TwisTorr 20 m pump extension cable	9699948M002
Turbo-V 750/850 TwisTorr 30 m pump extension cable	9699948M005
Turbo-V 750/850 TwisTorr 50 m pump extension cable	9699948M006

Turbo Pumps

AGILENT TURBO PUMP MODELS

▶ Agilent Turbo-V 850 TwisTorr System

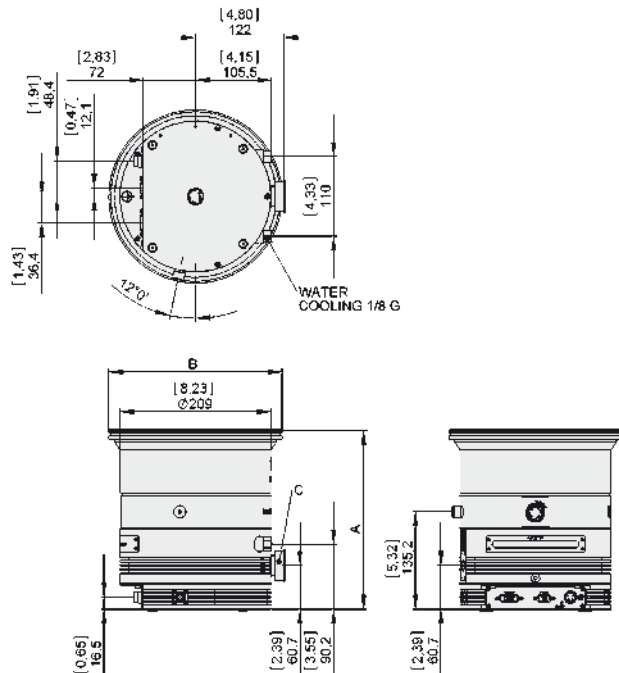

Dimensions: millimeters (inches)

Technical Specifications

Vacuum Performances

Pumping speed for N ₂ (*)	N ₂ = 750 l/s
Pumping speed for Ar (*)	Ar = 700 l/s
Pumping speed for He (*)	He = 690 l/s
Pumping speed for H ₂ (*)	H ₂ = 590 l/s
Compression ratio for N ₂	N ₂ = 1 x 10 ¹¹
Compression ratio for Ar	Ar > 1 x 10 ¹¹
Compression ratio for He	He = 2 x 10 ⁸
Compression ratio for H ₂	H ₂ = 2.5 x 10 ⁶
Base pressure*	<1 x 10 ⁻¹⁰ mbar
<i>(with minimum recommended forepump)</i>	
Max foreline pressure for N ₂	6 mbar
Inlet Flange size	ISO 200K, CFF 10", ISO 200F
Foreline flange	KF25 (ISO 200K, CFF 10") KF40 (ISO 200F)

Other

Rotational speed	Selectable from 350 Hz to 825 Hz
Start up time (90% of full speed)	< 3 min
Recommended forepump	PTS300, DS302, IDP-15
Operational position	Any
Cooling options	Forced Air (up to 35 °C ambient temp.) Water (corrosion resistant loop)
Max flange temperature during bake-out (no gas flow)	120°C (CFF), 80°C (ISO)
Noise level (pump at full speed, no load)	FAN off < 52 dB(A) at 1 meter FAN on < 55 dB(A) at 1 meter
Storage temperature	-20 °C to +70 °C
Certifications	CE, C, CSA_US, ROHS compliant
Purge and Vent	Standard Purge & Vent ports Automated Purge/Vent device (accessory)
Weight (with integrated controller)	ISO 200 K = 16.1 kg (35.5 lbs) CFF 10" = 22.6 kg (49.8 lbs)

(*): According to Pneuop 5608 III, TS 300 PRIMARY PUMP, NO INLET SCREEN

Model	Inlet Flange	A	B	C
9698815	ISO 200K	247.7 (9.75)	Ø 240 (9.45)	KF 25
9698816	CFF 10"	247.7 (9.75)	Ø 253.2 (9.97)	KF 25
9698819	ISO 200F	248.1 (9.77)	Ø 284.86 (11.21)	KF 40

Controller Specifications

Controller type	Fully integrated electronics
Motor control mode	Field Oriented Control (FOC)
Input voltage	48 Vdc (± 10%)
Maximum input power	450 W
Maximum output power	400 W (pump ramp-up) 300 W (water cooling) 200 W (forced air cooling)
Input voltage for power supply	100 – 240 Vac (± 10%)
Input frequency for power supply	50 – 60 Hz
Maximum input power for power supply	550 VA
Maximum operating power for power supply	450 W
Interface	Navigator standard remote I/O RS 232, RS 485 serial Can accept Profibus external device
Protection category	IP 54
Data Logger	Standard
Stop speed reading	Standard
Automated Purge/Vent device control	Standard
Leak Detector Mode function	Standard

TURBO PUMPS

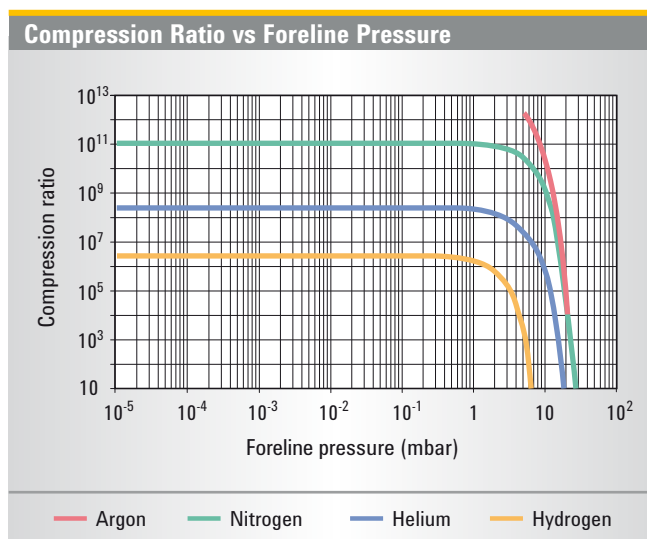
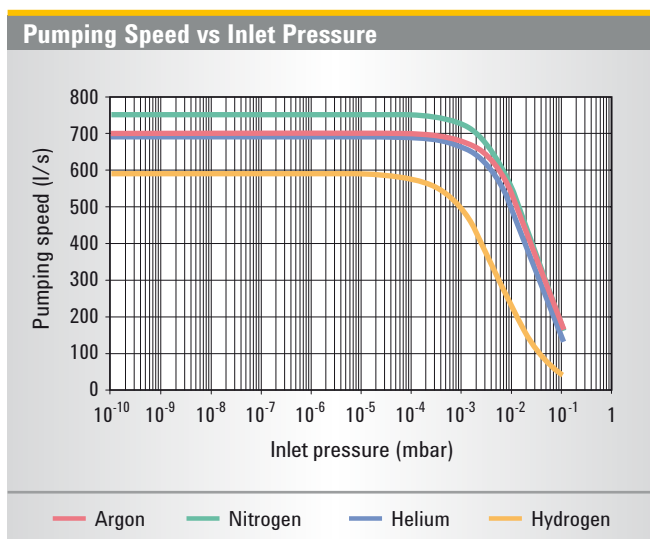

Ordering Information

Pumping Systems*	Part Number
Agilent Turbo-V 850 ISO 200K On-Board	9698815
Agilent Turbo-V 850 CFF 10" On-Board	9698816
Agilent Turbo-V 850 ISO 200F On-Board	9698819

(*): Pumping Systems include pump with integrated controller 48 Vdc, inlet screen, 9 and 15 pin mating connectors IP-54.

Accessories

Turbo-V 750/850 TwisTorr Power Supply (5 m pump cable)*	9696521
Mains cable NEMA Plug, 3 m long	9699958
Mains cable European Plug, 3 m long	9699957
Turbo-V 750/850 TwisTorr Purge/Vent Device N.C. (0.2 m cable)	9696502
Turbo-V 750/850 TwisTorr Fan (0.2 m cable)	9696503
T-Plus software and serial cable	9699883
Inlet screen ISO 200 and CFF 10"	9699316
Water cooling kit (plastic model)	9699347
Water cooling kit (metallic model)	9699337
Water kit, Hose tail 1/8G	9699828
Vibration isolator, ISO 200	9699346
Vibration isolator, CFF 10"	9699336
Vent flange, NW 10 KF / M8	9699108
Purge valve with KF16-M12 10 SCCM	9699239
Purge valve with 7/16-M12 10 SCCM	9699240
Purge valve KF16-M12 20 SCCM	9699241
Purge valve 7/16-M12 20 SCCM	9699242
External Profibus TMP gateway	9699261
Forepump DS 302, with 1 ph., universal motor	9499325
TriScroll Dry Vacuum Pump PTS 300 single phase, US cord	PTS03001UNIV
TriScroll Dry Vacuum Pump PTS 300 single phase, Euro cord	PTS03001UNIVEU
TriScroll Dry Vacuum Pump PTS 300 single phase, UK cord	PTS03001UNIVUK
TriScroll Dry Vacuum Pump PTS 300 3 phase	PTS03003UNIV
IDP-15 Dry Scroll Pump, Std	X3815-64000
IDP-15 Dry Scroll Pump, Std with inlet valve	X3815-64010

(*) Power Supply is necessary to provide 48 VDC to the on board electronics.

AGILENT TURBO PUMP MODELS

▶ Agilent Turbo-V 850 TwisTorr Rack

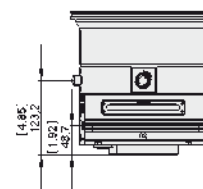
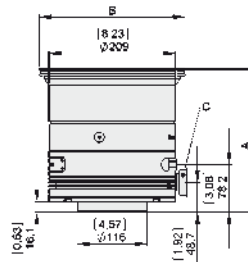
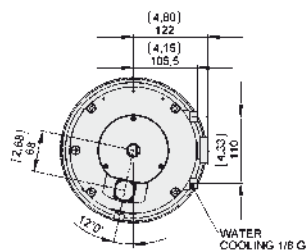

Model	Inlet Flange	A	B	C
9696015	ISO 200K	235.7 (9.28)	Ø 240 (9.45)	KF 25
9696016	CFF 10"	235.7 (9.28)	Ø 253,2 (9.97)	KF 25
9696019	ISO 200F	236.2 (9.30)	Ø 284,86 (11.21)	KF 40

Technical Specifications

Vacuum Performances

Pumping speed for N ₂ (*)	N ₂ = 750 l/s
Pumping speed for Ar (*)	Ar = 700 l/s
Pumping speed for He (*)	He = 690 l/s
Pumping speed for H ₂ (*)	H ₂ = 590 l/s
Compression ratio for N ₂	N ₂ = 1 x 10 ¹¹
Compression ratio for Ar	Ar > 1 x 10 ¹¹
Compression ratio for He	He = 2 x 10 ⁸
Compression ratio for H ₂	H ₂ = 2.5 x 10 ⁶
Base pressure*	<1 x 10 ⁻¹⁰ mbar
<i>(with minimum recommended forepump)</i>	
Max foreline pressure for N ₂	6 mbar
Inlet Flange size	ISO 200K, CFF 10", ISO 200F
Foreline flange	KF25 (ISO 200K, CFF 10") KF40 (ISO 200F)

Other

Rotational speed	Selectable from 350 Hz to 825 Hz
Start up time (90% of full speed)	< 6 min (with 5 m pump cable length)
Recommended forepump	PTS300, DS302, IDP-15
Operational position	Any
Cooling options	Forced Air (up to 35 °C ambient temp.) Water (corrosion resistant loop)
Max flange temperature during bake-out (no gas flow)	120 °C (CFF), 80 °C (ISO)
Noise level (pump at full speed, no load)	FAN off < 52 dB(A) at 1 meter FAN on < 55 dB(A) at 1 meter
Storage temperature	-20 °C to +70 °C
Certifications	CE, C, CSA_US, ROHS compliant
Purge and Vent	Standard Purge & Vent ports Automated Purge/Vent device (accessory)
Weight	ISO 200 K = 15.8 kg (34.8 lbs) CFF 10" = 22.4 kg (49.4 lbs)

(*): According to Pneurop 5608 III, TS 300 PRIMARY PUMP, NO INLET SCREEN

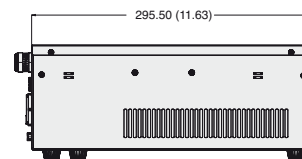
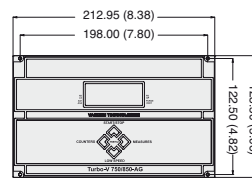

Dimensions: millimeters (inches)

Controller Specifications	Controller Models 9699525-9699526	Controller Model X3501-64000
Input voltage	100 – 240 Vac (± 10%)	100 – 240 Vac (± 10%)
Input frequency	50 – 60 Hz	50 – 60 Hz
Maximum input power	600 VA	800 VA
Maximum output power	320 W (pump ramp-up) 300 W (water cooling) 200 W (forced air cooling)	420 W 300 W 200 W
<i>(Specification with standard cable length 5 mt)</i>		
Interface	Navigator standard remote I/O RS 232, RS 485 serial Can accept Internal Profibus board	Navigator standard remote I/O RS 232
Protection category	IP 20	IP 20
Data Logger	Standard	No
Stop speed reading	Standard	Yes
Active stop	Standard	Yes
Automated Purge/Vent device control	Standard	Yes
External gauge readout	2 ports compatible with Agilent gauges	No
Primary pump control	Pilot 2 external configurable relays (48 Vdc (± 10%) - 250 mA MAX)	Yes

TURBO PUMPS

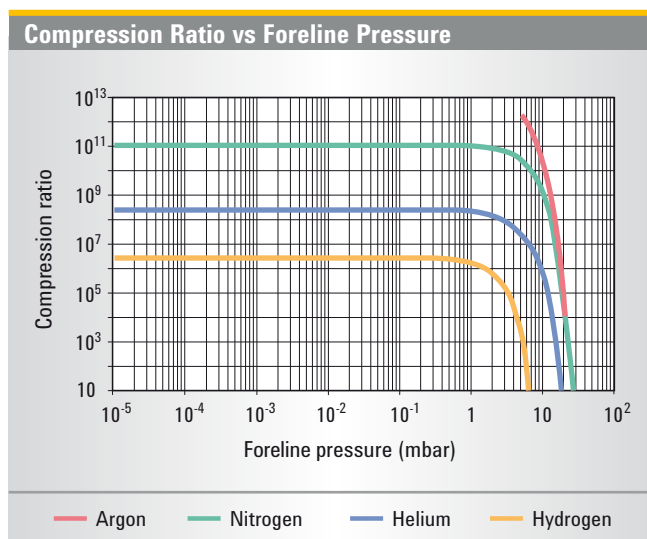
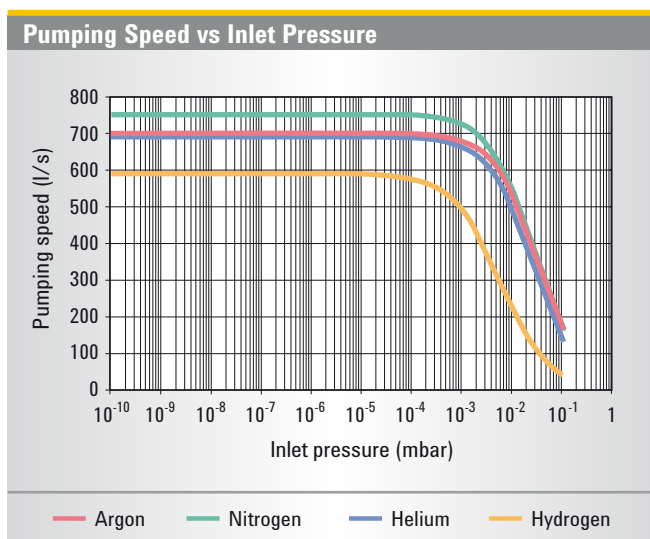

Ordering Information

Pumps	Part Number
Agilent Turbo-V 850 ISO 200K Rack	9696015
Agilent Turbo-V 850 CFF 10" Rack	9696016
Agilent Turbo-V 850 ISO 200F Rack	9696019

Controllers

Agilent Turbo-V 750/850-AG Rack CNT (5 m pump cable incl. - max TMP cable 25 m)	9699525
Agilent Turbo-V 750/850-AG Rack CNT Profibus (5 m pump cable incl. - max TMP cable 25 m)	9699526
Agilent Turbo-V 750/850-AG Rack CNT Profibus (5 m pump cable incl. - max TMP cable 60 m)	X3501-64000

General Accessories

Mains cable NEMA Plug, 3 m long	9699958
Mains cable European Plug, 3 m long	9699957
T-Plus software and serial cable	9699883
Inlet screen ISO 160 and CFF 8"	9699304
Inlet screen CFF 6"	9699302
Water cooling kit (plastic model)	9699347
Water cooling kit (metallic model)	9699337
Water kit, Hose tail 1/8G	9699828
Vibration isolator, ISO 160	9699345
Vibration isolator, CFF 6"	9699334
Vibration isolator, CFF 8"	9699335
Vent flange, NW 10 KF / M8	9699108
Purge valve with KF16-M12 10 SCCM	9699239
Purge valve with 7/16-M12 10 SCCM	9699240
Purge valve KF16-M12 20 SCCM	9699241
Purge valve 7/16-M12 20 SCCM	9699242

Controller Accessories (9699525-9699526)	Part Number
Turbo-V 750/850 TwisTorr Purge/Vent Device N.C. (0.2 m cable)	9696502
Turbo-V 750/850 TwisTorr Fan (0.2 m cable)	9696503
Turbo-V 750/850 TwisTorr Purge/Vent 5 m extension cable	9696504
Turbo-V 750/850 TwisTorr Purge/Vent 15 m extension cable	9696505
Turbo-V 750/850 TwisTorr Purge/Vent 25 m extension cable	9696506
Turbo-V 750/850 TwisTorr Fan 5 m extension cable	9696514
Turbo-V 750/850 TwisTorr Fan 15 m extension cable	9696515
Turbo-V 750/850 TwisTorr Fan 25 m extension cable	9696516
Turbo-V 750/850 TwisTorr 10 m pump extension cable	9696518
Turbo-V 750/850 TwisTorr 20 m pump extension cable	9696519

Controller Accessories (X3501-64000)

Air cooling kit (24 V)	X3501-68000
Vent valve extension cable - 5 m	X3501-68004
Turbo-V 750/850 TwisTorr 3 m pump extension cable	9699948
Turbo-V 750/850 TwisTorr 5 m pump extension cable	9699948M001
Turbo-V 750/850 TwisTorr 20 m pump extension cable	9699948M002
Turbo-V 750/850 TwisTorr 30 m pump extension cable	9699948M005
Turbo-V 750/850 TwisTorr 50 m pump extension cable	9699948M006

AGILENT TURBO PUMP MODELS

▶ Agilent Turbo-V 1001 Navigator

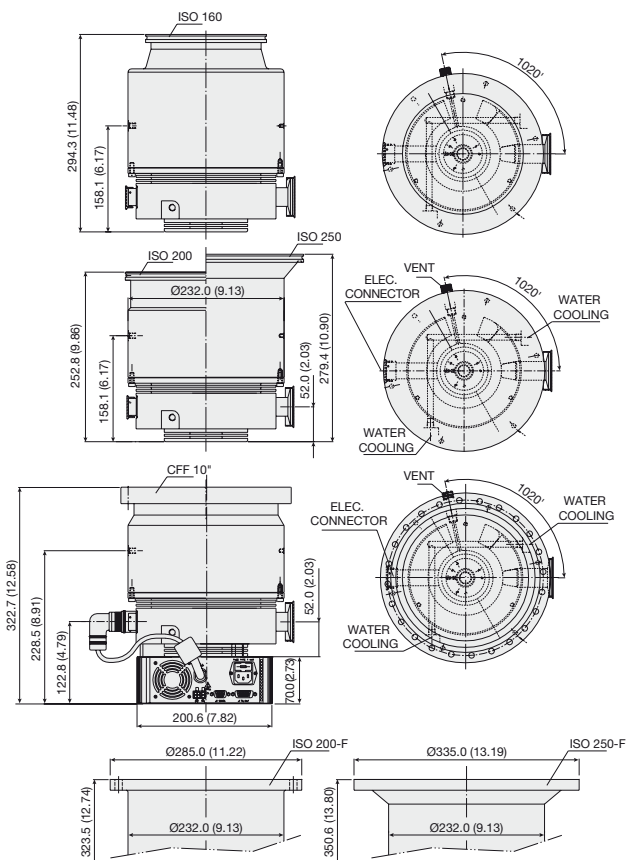

Dimensions: millimeters (inches)

Technical Specifications

Pumping speed:	ISO 160:	N ₂ : 790 l/s	He: 820 l/s	H ₂ : 860 l/s
	CFF 10" or ISO 200:	N ₂ : 950 l/s	He: 870 l/s	H ₂ : 900 l/s
	ISO 250:	N ₂ : 1,050 l/s	He: 900 l/s	H ₂ : 920 l/s
Compression ratio:	ISO 160	N ₂ : 1 x 10 ⁹	He: 1 x 10 ⁷	H ₂ : 1 x 10 ⁶
	CFF 10"/ISO 200 - ISO 250	N ₂ : 1 x 10 ⁹	He: 1 x 10 ⁷	H ₂ : 1 x 10 ⁶
Base pressure* (with recommended forepump)	< 1 x 10 ⁻¹⁰ mbar (< 1 x 10 ⁻¹⁰ Torr)			
Inlet flange	ISO 160	ISO 200	ISO 200-F bolted	CFF 10" ISO 250 ISO 250-F bolted
Foreline flange	KF 40			
Rotational speed	38,000 rpm			
Start-up time	< 4 minutes			
Recommended forepump	Mechanical: Agilent DS 402 Dry scroll: Agilent TS300, IDP-15			
Operating position	Any			
Cooling requirements	Forced air or water			
Bakeout temperature	120 °C at inlet flange max. (CF flange) 80 °C at inlet flange max. (ISO flange)			
Vibration level (displacement)	< 0.01 µm at inlet flange			
Weight kg (lbs):	ISO 160 flange	19 (41.8)		
	ISO 200 flange	19.4 (43.0)		
	CF 10" flange	25.5 (54.2)		
	ISO 250 flange	21.2 (46.6)		
	ISO 200-F and 250-F bolted flange, CF 10" flange	25.5 (54.2)		

* According to standard DIN 28 428.

NOTE • The pump is available with On-board Navigator controller, ½ Rack controller or PCB controller; for information on controllers see also following pages.

SEM version available on request

TURBO PUMPS

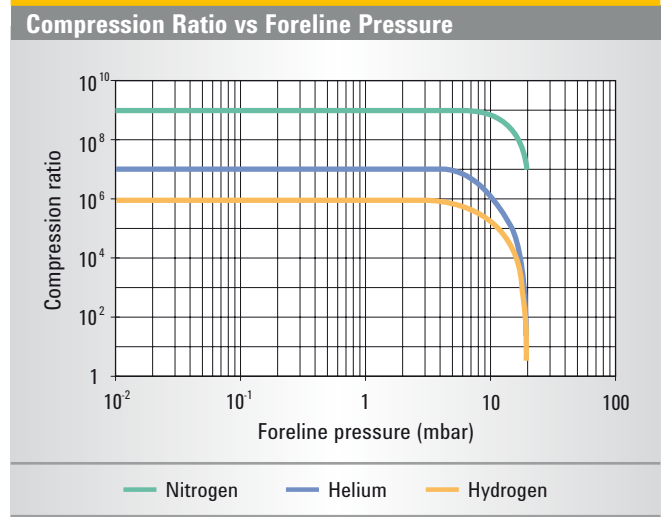
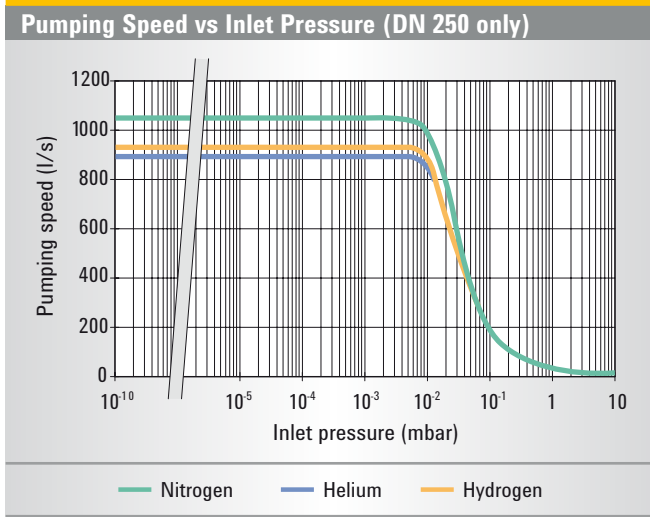

Ordering Information

Description	Weight kg (lbs)	Part Number
-------------	--------------------	----------------

Complete Systems

Turbo-V 1001 Navigator complete system, ISO 160 flange	24.4 (53.8)	9698840
Turbo-V 1001 Navigator complete system, ISO 200 flange	24.8 (55.0)	9698838
Turbo-V 1001 Navigator complete system, ISO 200-F bolted flange	30.9 (66.2)	9698844
Turbo-V 1001 Navigator complete system, 10" CF flange	30.9 (66.2)	9698839
Turbo-V 1001 Navigator complete system, ISO 250 flange	26.6 (58.6)	9698841
Turbo-V 1001 Navigator complete system, ISO 250-F bolted flange	30.9 (66.2)	9698845

Complete system includes: Pump, Inlet screen, Controller mounted on the bottom, 2 Mains cables (NEMA plug and European plug).

Pumps

Turbo-V 1001 Navigator pump, ISO 160 flange	19.0 (41.8)	9698933
Turbo-V 1001 Navigator pump, ISO 200 flange	19.4 (43.0)	9698931
Turbo-V 1001 Navigator pump, ISO 200-F bolted flange	25.5 (54.2)	9698946
Turbo-V 1001 Navigator pump, 10" CF flange	25.5 (54.2)	9698932
Turbo-V 1001 Navigator pump, ISO 250 flange	21.2 (46.6)	9698934
Turbo-V 1001 Navigator pump, ISO 250-F bolted flange	25.5 (54.2)	9698947

Controllers (See following pages for specifications)

Turbo-V 1001 Navigator controller 120/220 V - 50/60 Hz	5.4 (12.0)	9698978
Turbo-V 1001 Rack controller, 100-240 V	15.7 (35.0)	X3501-64003

Description	Weight kg (lbs)	Part Number
-------------	--------------------	----------------

Pump Accessories

Mains cable NEMA plug, 3 m long		9699958
Mains cable European plug, 3 m long		9699957
Serial cable and T-plus Software (previous release Navigator 2.2 included in the CD)		9699883
Inlet screen DN 160		9699304
Inlet screen DN 200		9699316
Inlet screen DN 250		9699350
Water cooling kit		9699337
Plastic water cooling kit		9699347
Air cooling kit for use with Navigator controller		9699297
Air cooling kit for use with standard rack controller		X3501-68001
Bracket for Navigator controller side routing		9699298
Vibration damper ISO 160	4.0 (9.0)	9699345
Vibration damper, ISO 200	5.0 (10.0)	9699346
Vibration damper, CFF 10"	5.0 (10.0)	9699336
Vent flange, NW 10 KF / M8		9699108
Vent device with adjustable delay time for standard rack controller		9699831
Vent valve for standard rack controller		X3501-68002
Vent valve for Navigator controller		9699834
Purge valve 10 SCCM NW16KF - M12		9699239
Purge valve 10 SCCM ¼ Swagelok - M12		9699240
Purge valve 20 SCCM NW16KF - M12		9699241
Purge valve 20 SCCM ¼ Swagelok - M12		9699242
Purge valve 10 SCCM ¼ Swagelok ¼ Swagelok		9699232
Purge Valve 20 SCCM ¼ Swagelok ¼ Swagelok		9699236

AGILENT TURBO PUMP CONTROLLERS

▶ Agilent Turbo-V 1001 Navigator Controller

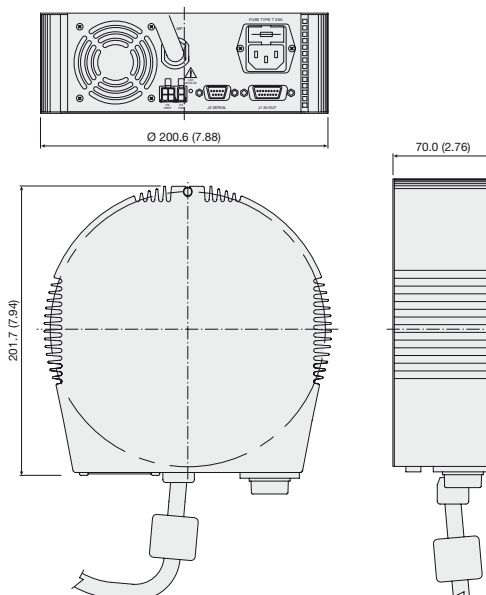

Dimensions: millimeters (inches)

The Turbo-V 1001 Navigator controllers are microprocessor-controlled frequency converters, fully controllable through PC software, with self-diagnostic and protection features that ensure the highest degree of reliability. They can be mounted on board, either on the bottom or on the side of the pump, offering outstanding flexibility and simplicity.

Technical Specifications

Input voltages	100/120/220/240 VAC
	50/60 Hz, 1 ph
Maximum input power	850 VA
Output voltage	54 VAC, 3 ph
Output frequency	640 Hz
Operating temperature	0 °C to +40 °C
Storage temperature	-20 °C to +70 °C

Ordering Information

Description	Weight kg (lbs)	Part Number
Controllers		
Turbo-V 1001 Navigator controller 120/220 V - 50/60 Hz	3.0 (6.0)	9698978
Accessories		
Mains cable NEMA plug, 3 m long	0.5 (1.0)	9699958
Mains cable European plug, 3 m long	0.5 (1.0)	9699957
Serial cable and T-plus Software <i>(previous release Navigator 2.2 included in the CD)</i>	0.5 (1.0)	9699883
External "TMP Profibus gateway"	0.4 (0.8)	9699261

TURBO PUMPS

▶ Agilent Turbo-V 1001 Rack Controller

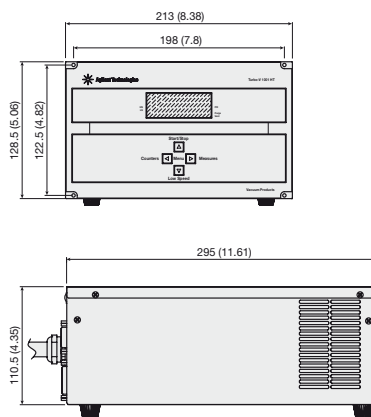

Dimensions: millimeters (inches)

These controllers are microprocessor-controlled frequency converters with self diagnostic and protection features that ensure the highest degree of reliability. The compact, ½ rack unit has a multifunction alphanumeric display for pump status and error code diagnostics. The front panel has a two-line dot matrix LCD display with back lighting. It displays rotational speed as the pump starts up and indicates when full speed is reached. At any time during the operation of the pump, the speed, current, power, and bearing temperature can be displayed. Additionally, the microprocessor acts as a pump

cycle log, and can display the number of vacuum cycles, the cycle time for the current cycle, and the total operating hours on the pump. Remote operation can be accomplished with logic level contact closures and with optional computer interfaces.

PCB controllers are available. Please contact Agilent for details.

Technical Specifications

Input voltages	100-240 V 1 ph, 50/60 Hz
Maximum input power	800 VA
Output voltage	56 VAC, 3 ph
Output frequency	633 Hz
Maximum output power*	450 W
Startup power	450 W
Operating temperature	+5 °C to +45 °C
Storage temperature	-20 °C to +70 °C

* Data valid for nitrogen.

Ordering Information

Description	Weight kg (lbs)	Part Number
Controller		
Turbo-V 1001 Rack controller, 100-240 V	15.7 (35.0)	X3501-64003
Accessories		
Mains cable (European plug, 3 m long)		9699957
Mains cable (American plug, 120 V, 3 m long)		9699958
Options		
Rack adapter for controller	2.0 (4.0)	9699191
Controller to pump extension cable (5 m extension) for Turbo-V 1001	1.0 (2.0)	9699948M001
Controller to pump extension cable (12 m extension) for Turbo-V 1001	2.0 (4.0)	9699951S029
Controller to pump extension cable (20 m extension) for Turbo-V 1001	4.0 (8.0)	9699948M002
External "TMP Profibus gateway"	0.4 (0.8)	9699261

AGILENT TURBO PUMP MODELS

▶ Agilent Turbo-V 2300 TwisTorr Rack

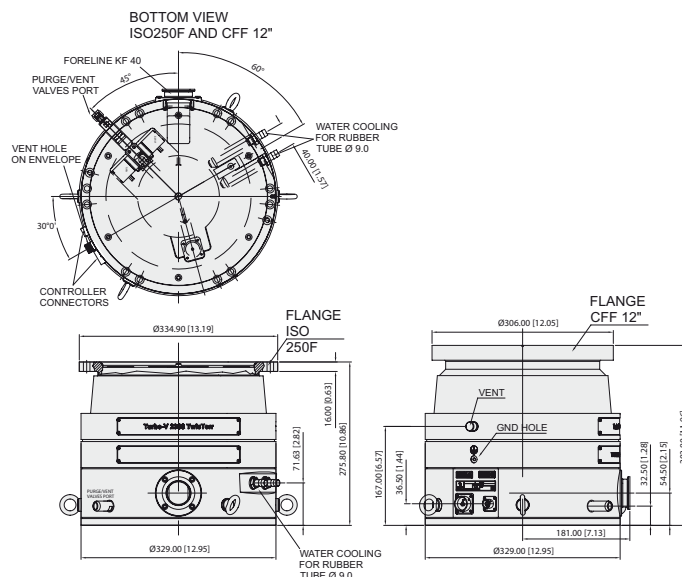

Technical Specifications

Vacuum Performances

Pumping speed for N ₂ (*)	2050 l/s
Pumping speed for He (*)	1800 l/s
Pumping speed for H ₂ (*)	1500 l/s
Compression ratio for N ₂	>8 x 10 ⁸
Compression ratio for He	8 x 10 ⁵
Compression ratio for H ₂	4 x 10 ⁴
Base pressure* (with recommended forepump)	10 ⁻¹⁰ mbar (7.5 x 10 ⁻¹¹ Torr) (**)
Max foreline pressure for N ₂	4 mbar
Inlet Flange	ISO 250F, CFF 12" O.D.
Foreline flange	KF 40 NW

Other

Nominal rotational speed	33300 rpm
Start-up time without gas load and with the recommended forepump	< 6 minutes
Minimum recommended forepump	TriScroll 600
Operational position	Any
Operating ambient temperature	+5 °C to +35 °C
Bakeout temperature	120 °C (CFF), 80 °C (ISO)
Max rotor temperature	120 °C
Vibration level (displacement)	< 0.01 μm at inlet flange
Lubricant	Permanent lubrication
Cooling requirements	Water
Coolant water	Recommended flow: 200 l/h Temperature: +15 °C to +30 °C Pressure: 3 to 5 bar (45 to 75 psi)
Noise level	<60 dB(A) at 1 meter
Storage temperature	-20 °C to +70 °C
Environment protection	IP54
Weight	ISO 250: 54.2 kg (119.5 lbs) CFF 12": 55.3 kg (121.9 lbs)

(*): WITHOUT INLET SCREEN

(**): According to standard DIN 28 428, the base pressure is that measured in a leak-free test dome, 48 hours after the completion of test dome bake-out, with a Turbopump fitted with a CFF flange and using the recommended pre-vacuum pump

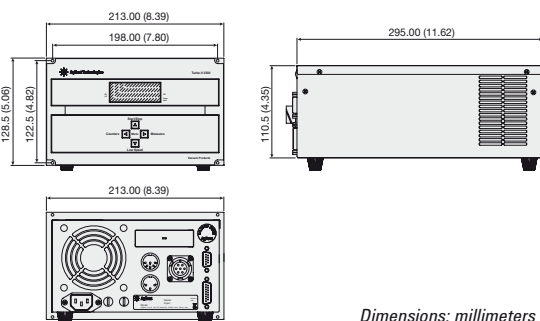

Dimensions: millimeters (inches)

Controller Specifications

Input voltages	100-120 VAC, 220-240 Vac, 1-phase
Input frequency	50 - 60 Hz
Maximum input power	1300 VA
Output voltage	64 Vac
Output frequency	555 Hz
Output Power starting	560 W maximum
Output Power normal	450 W maximum
Weight (both models)	12.5 kg (28 lbs)
Installation category	II
Pollution degree	2

TURBO PUMPS

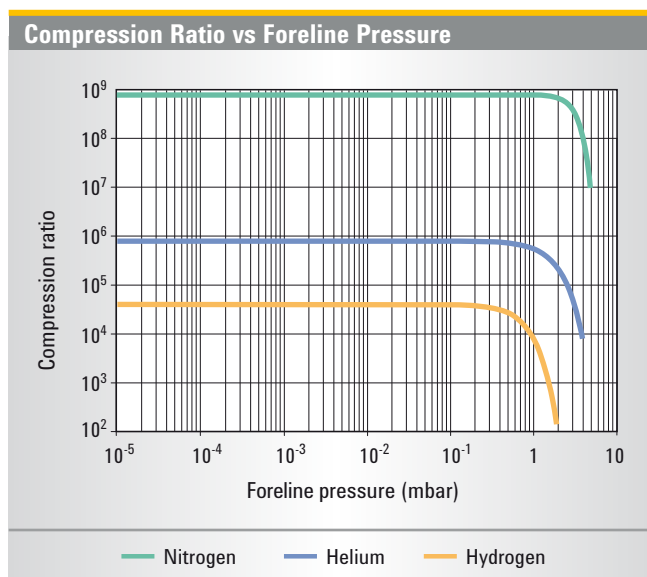
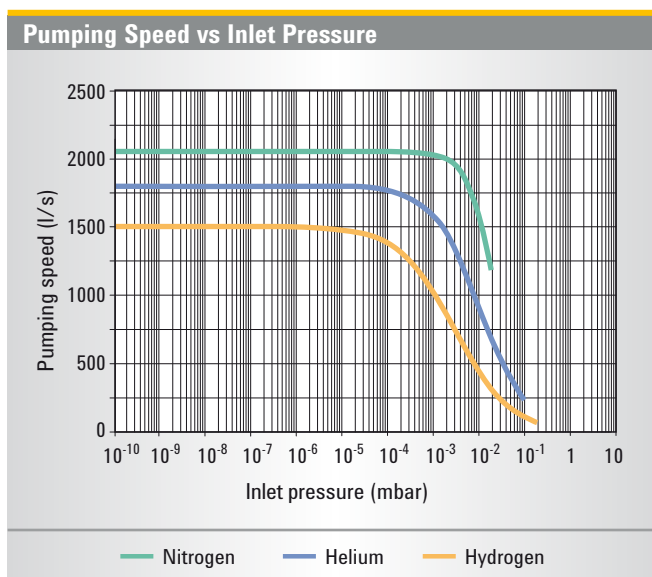

Ordering Information

Pump	Part Number
Agilent Turbo-V 2300 TwisTorr ISO250F Rack	9696000
Agilent Turbo-V 2300 TwisTorr CFF12" OD Rack	9696001

Controllers*

Agilent Turbo-V 2300 Rack controller, 100-240 V	X3501-64004
Agilent Turbo-V 2300 Pump-Controller Cable kit, 5 m, for pump and vent valve operation	X3501-68003

(*): Please note that rack controllers do not include the Pump-Controller Cable Kit

Accessories

Mains cable NEMA Plug, 3 m long	9699958
Mains cable European Plug, 3 m long	9699957
Center-ring ISO 250	9699144
Inlet screen DIN ISO 250 // CFF12" AISI	9699350
Water cooling kit for 6x8 (IDxOD) flexible tube	9699348
Water cooling kit for 3/8 in. ID flexible tube	9699338

AGILENT TURBO PUMP MODELS

▶ Agilent Turbo-V 1K-G

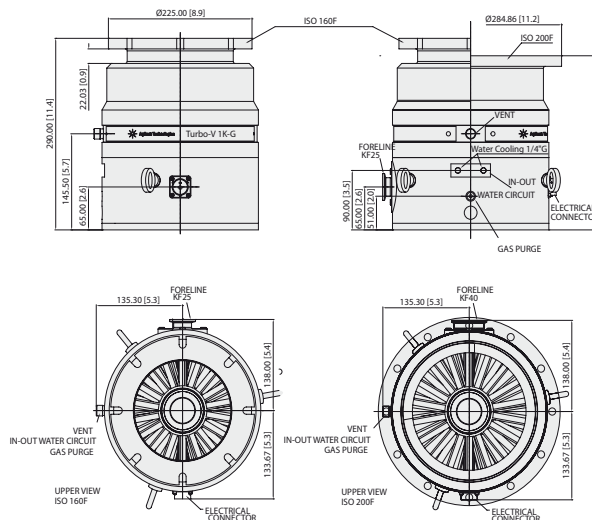

Dimensions: millimeters (inches)

Turbo-V 1K-G

- Application-specific pumping solution designed for thin film deposition equipment
- High pumping speed and high gas throughput
- Rugged design and highly efficient cooling system for continuous operation
- Gas Purge for bearings protection

Advanced Electronics

- Rack type or Navigator on board controllers
- Versatile electronics interface with easy to use control Software
- Analog I/O signals and RS232 / RS485 interface as standard Agilent Profibus interface as option

Technical Specifications

Pumping speed:	ISO 160:	Ar: 750 l/s	N ₂ : 810 l/s	He: 950 l/s	H ₂ : 680 l/s
	ISO 200:	Ar: 1,040 l/s	N ₂ : 1,080 l/s	He: 1,150 l/s	H ₂ : 730 l/s
Compression ratio:		Ar: > 5 x 10 ⁸	N ₂ : > 5 x 10 ⁷	He: > 4 x 10 ⁴	H ₂ : 1.5 x 10 ⁴
Base pressure* (with recommended forepump)		< 1 x 10 ⁻¹⁰ mbar			
Inlet flange		ISO 160 F, ISO 200 F			
Foreline flange	ISO 160:	KF 25 NW			
	ISO 200:	KF 40 NW			
Nominal rotational speed		45,500 rpm			
Start-up time		< 5 minutes			
Minimum recommended forepump		> 20 m ³ /h (TriScroll 600, DS 602)			
Operating position		Any			
Operating ambient temperature		+5 °C to +35 °C			
Bakeout temperature		80 °C at inlet flange max. (ISO flange)			
Vibration level (displacement)		< 0.01 µm at inlet flange			
Cooling requirements		Water			
Power supply	Input voltage: 100-240 Vac	Input freq.: 50 - 60 Hz	Max input power: 600 VA	Stand-by power: 30 to 35 W	
	Max operating power: 400 W using Nitrogen and lighter gases (water cooling setting) 260 W using Argon (air cooling setting)				
Protection fuse (Navigator controller)		1 x 6.3 A			
Serial communication (Navigator Kit)		RS232 cable with a 9-pin D type male connector and a 9-pin D type female connector, and Navigator software (optional)			
Storage temperature		-20 °C to +70 °C			
Weight		26.8 kg (59.1 lbs)			

* According to standard DIN 28 428.

TURBO PUMPS

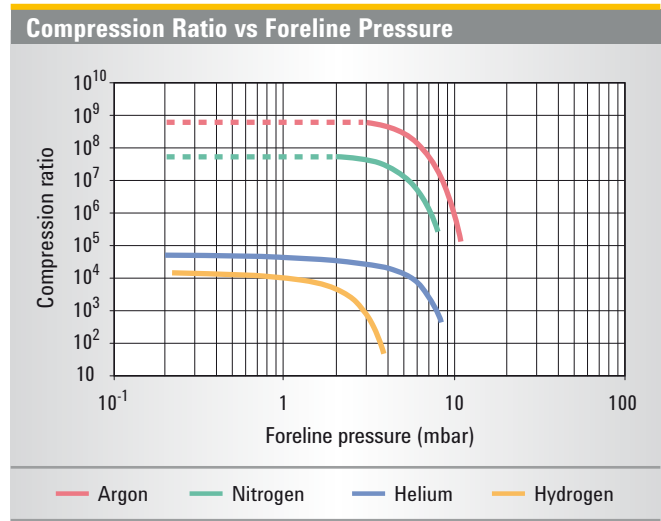
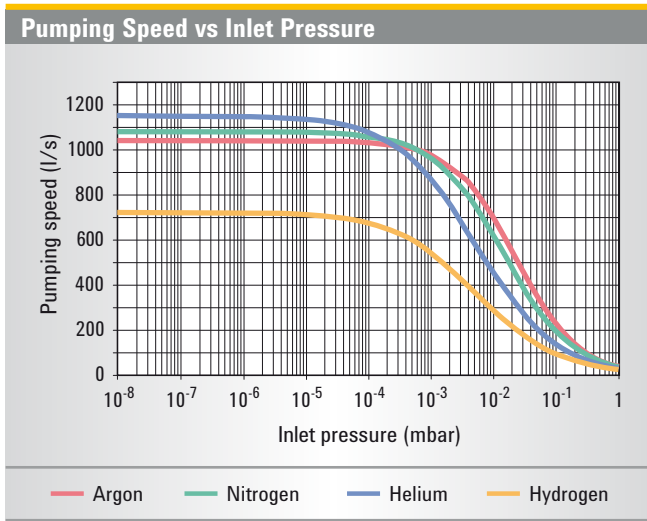

Ordering Information

Description	Part Number
Pumping Systems	
Turbo-V 1K-G ISO160 F	8698961R002
Turbo-V 1K-G ISO200 F	8698962R001
Controllers	
Turbo-V 1K-G Navigator controller, 120-220 V	9698978M005
Turbo-V 1K-G Rack controller, 100-240 V	X3501-64005
Accessories	
Mains cable NEMA Plug, 3 m long	9699958
Mains cable European Plug, 3 m long	9699957
Serial cable and Navigator Software	9699883
Inlet screen ISO 160	9699304
Inlet screen ISO 200	9699316
Water cooling kit (hose tail G ¼)	9699825
Water cooling kit (Inox G ¼)	9699826
Vent flange, NW 10 KF / M8	9699108
Vent device with adjustable delay time for standard rack controller	9699831
Vent valve for standard rack controller	X3501-68002
Vent valve for Navigator controller	9699834
Purge valve KF16-M12 20 SCCM	9699241
Purge valve 7/16-M12 20 SCCM	9699242
Recommended Forepump	
Rotary Vane pump DS 602, with 1 ph, worldwide motor	9499335
Rotary Vane pump DS 602, with 3 ph, worldwide motor	9499336
Rotary Vane pump HS 452, with 1 ph, worldwide motor	9499360
Rotary Vane pump HS 652, with 1 ph, worldwide motor	9499365
Dry pump TriScroll 600, with 1 ph, worldwide motor	PTS06001UNIV
Dry pump TriScroll 600, with 3 ph, worldwide motor	PTS06003UNIV
Dry pump TriScroll 600 inverter, with 1 ph, worldwide motor	PTS06001INV

AGILENT TURBO PUMP MODELS

▶ Agilent Turbo-V 2K-G System

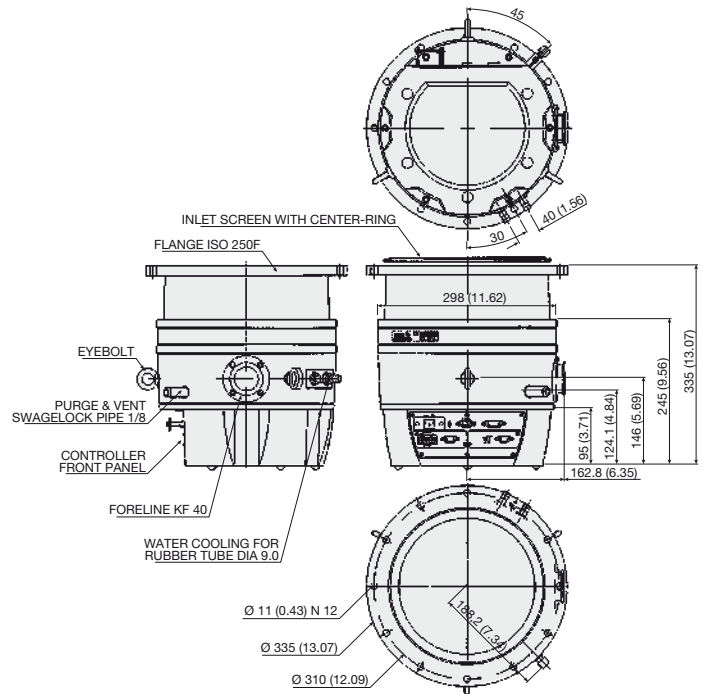

Dimensions: millimeters (inches)

Turbo-V 2K-G System

- The first application-specific pumping solution designed for thin film deposition equipment
- The highest performing, most compact unit available
- The first fully integrated approach for maximum system productivity and uptime

The System Interface

- Integrated package includes Turbo Molecular Pump, Drive Electronics, Power Supply, Purge Gas and Communication
- Versatile electronics interface with easy to use control Software
- Analog I/O signals and RS232 / RS485 interface as standard Agilent Profibus interface as option

Technical Specifications

Pumping speed		N ₂ : 1600 l/s
Compression ratio		N ₂ : 3 x 10 ⁵
Base pressure* (with recommended forepump)		< 1 x 10 ⁻⁸ mbar
Inlet flange		ISO 250 F
Foreline flange		KF 40 NW
Nominal rotational speed		33,000 rpm
Start-up time		<7 minutes
Recommended forepump		> 40 m ³ /h
Operating position		Any
Operating ambient temperature		+5 °C to +40 °C
Power supply	Input voltage	100 - 240 Vac
	Input freq.	50 - 60 Hz
Communication Interface	Analogue I/O	Standard
	RS232 / RS485	Standard
	Profibus	Optional
Dimensions	Height	335 mm (13.18 in.)
	Diameter	335 mm (13.18 in.)
	Weight	35 kg (77 lbs)

* According to standard DIN 28 428.

TURBO PUMPS

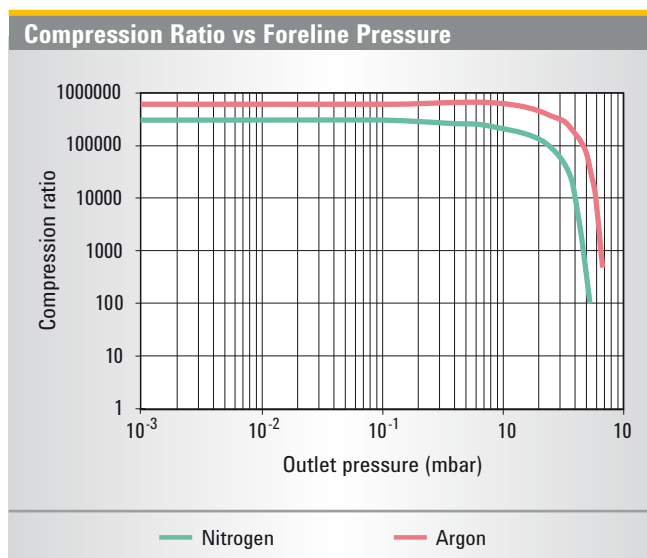
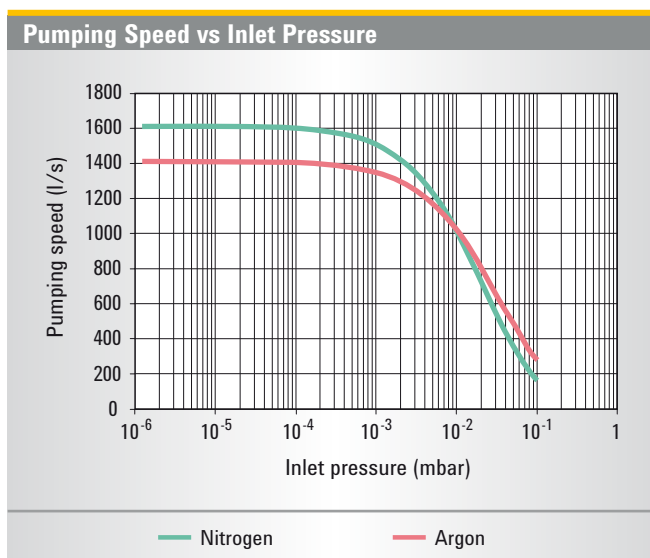

Ordering Information

Description	Part Number
Pumping Systems (*)	
Turbo-V 2K-G system with MoniTorr	9698871
Turbo-V 2K-G system with Profibus and MoniTorr	9698873
(*) Pumping Systems include Pump with 230 V Integrated Electronics, water hose connection, Inlet Screen with center-ring and pre-installed IP54 Mating Connectors. Both standard models can be equipped with Agilent's MoniTorr device on request. Also 120 Vac units available on request.	
Accessories	
Mains cable NEMA Plug, 3 m long	9699958
Mains cable European Plug, 3 m long	9699957
T-Plus Software and serial cable	9699883
Water cooling kit for 6x8 (IDxOD) flexible tube	9699348
Water cooling kit for 3/8 in.ID flexible tube	9699338
Turbo-V remote cable	9699945
Turbo-V remote panel	9698850
Spare Parts	
IP54 proof mating connectors	9699958
Inlet screen ISO 250 with center ring	9699138
Water hoses	9699825

AGILENT TURBO PUMP MODELS

▶ Agilent Turbo-V 3K-G System

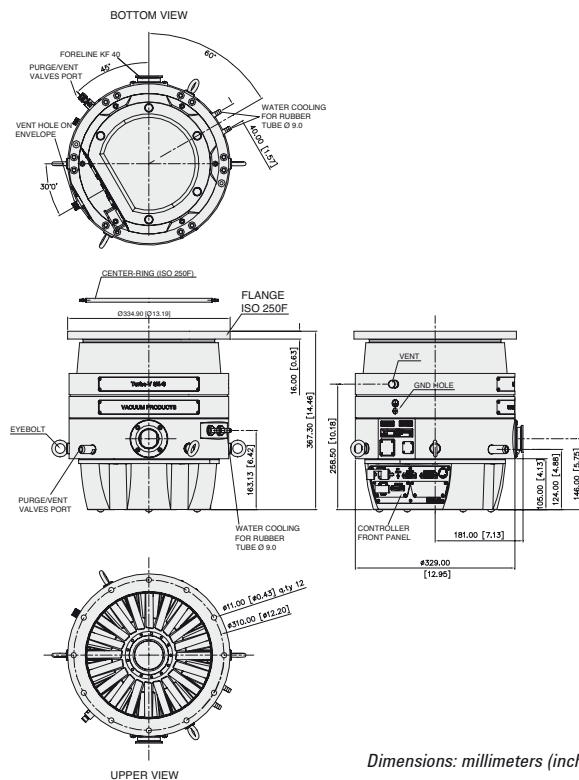

Dimensions: millimeters (inches)

The Only Truly “Integrated” System in the Market

The Turbo-V 3K-G: an advanced solution for Thin Film applications

- Fully integrated system with on board waterproof power supply
- Vent/purge valves control capability
- Integrated diagnostics
- Multiple interfaced capability
- Lowest power absorption

Best Footprint to Performance Ratio

- The highest Argon pumping speed (2050 l/s) for its size allows uniform deposition rates at high substrate throughput
- Highest pumping speed in its class: 2200 l/s for Nitrogen
- Throughput: over 1400 sccm for Nitrogen
- The all-turbo, more compact rotor design delivers highest performance with the smallest footprint

Technical Specifications

Pumping speed	N ₂ : 2200 l/s	He: 1900 l/s	Ar: 2050 l/s
Compression ratio	N ₂ : > 1 x 10 ⁷	He: 6 x 10 ³	Ar: > 1 x 10 ⁸
Base pressure* (with recommended forepump)	<1 x 10 ⁻⁸ mbar		
Inlet flange	ISO 250 F		
Foreline flange	KF 40 NW		
Nominal rotational speed	31,800 rpm		
Start-up time without gas load and with the recommended forepump	< 6 minutes		
Foreline pressure	< 0.5 mbar		
Minimum recommended forepump	> 60 m ³ /h (depending on gasflow requirements)		
Operating position	Any		
Cooling requirements	Water		
Weight (ISO 250)	52 kg (114.63 lbs)		

* According to standard DIN 28 428.

TURBO PUMPS

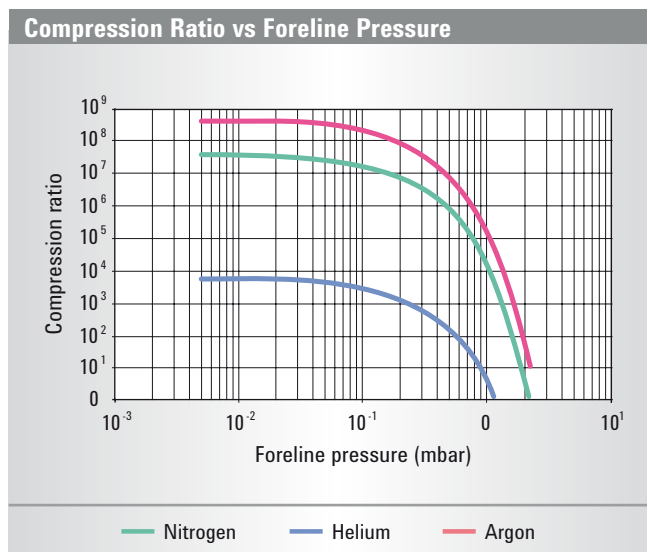
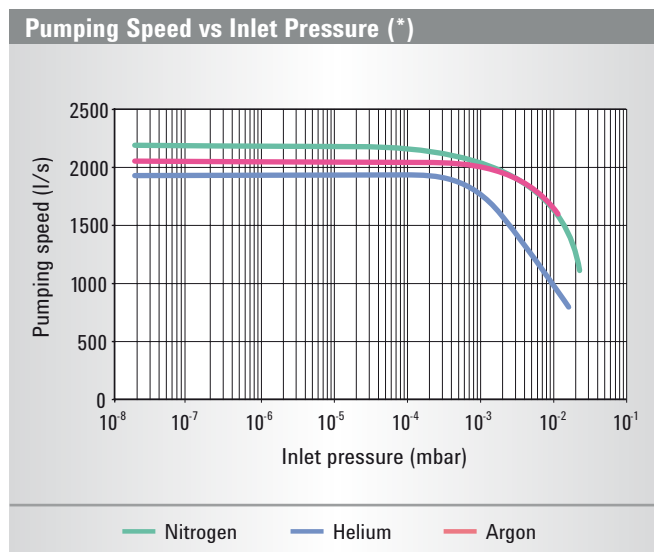

(*) Measured with a 60 m³/h forepump.

Ordering Information

Description	Part Number
Pumping Systems (*)	
Turbo-V 3K-G ISO 250 F System with integrated purge/vent device	9698888
Turbo-V 3K-G ISO 250 F System with Profibus and integrated purge/vent device	9698889
(*) Pumping Systems include Pump with 230 V Integrated Electronics, Inlet Screen installed on the pump, separate center-ring and pre-installed IP54 Mating Connectors. Both standard models can be equipped with Agilent's MoniTorr device on request. Also 120 Vac units available on request.	
Accessories	
Mains cable NEMA Plug, 3 m long	9699958
Mains cable European Plug, 3 m long	9699957
T-Plus Software and serial cable	9699883
Water cooling kit for 6x8 (IDxOD) flexible tube	9699348
Water cooling kit for 3/8 in.ID flexible tube	9699338
Spare Parts	
IP54 proof mating connectors	9699960
Inlet screen ISO 250	9699350
O-ring and center ring ISO250	9699144

AGILENT TURBO PUMP ACCESSORIES

Inlet Screens

To prevent any possible damage to the pump blades caused by particles falling into the pump, an inlet screen is available as an accessory. The inlet screen is a curved stainless steel mesh. It provides protection against debris larger than 0.7 to 3 mm (depending on the model), while reducing the pumping speed by only about 10%.

For ordering information, see individual pumps.

Air Cooling Kits

A fan is provided as an option for applications requiring forced air flow. The fan is easily installed using the included installation kit.

The air cooling kit for the Turbo-V 81's can be mounted beside or underneath the pump body. The fans for all the other pump models can be installed in a side location only. The maximum allowable ambient temperature for an effective cooling action is 30 °C. To meet the air flow rate specifications, care must be taken not to restrict or cover the space around the fan so that air can flow freely. The operation of the cooling fan is controlled by the Turbo controller.

For ordering information, see individual controllers.

Water Cooling Kits

A water cooling kit is provided to cool the pump when operating at high inlet or high exhaust pressures. The cooling water can be supplied by an open circuit with drainage or a closed-loop refrigerated system.

Care must be taken to secure the tubes to ensure that they do not detach during operation. Four different kits with various tube sizes are available (refer to the following table).

Tube Size	Material	Screw Thread	Part Number
4 x 6 mm (ID x OD)	Plastic	1/8 BSP	9699347
6 x 8 mm (ID x OD)	Plastic	1/4 BSP	9699348
1/4" ID	SST	1/8 BSP	9699337
3/8" ID	SST	1/4 BSP	9699338

For ordering information, see individual pumps.

Vibration Dampers

Highly sensitive equipment such as an electron microscope and certain analytical instruments require extremely low vibration amplitudes. The dampers reduce turbopump vibration

amplitude by at least a factor of 10 at their main frequencies. They are available up to a size of 200 mm (ISO 200 or CFF 10" O.D.). To effectively decouple the equipment from the pump, the vibration damper must be installed between the connecting flanges.

For ordering information, see individual pumps.

	H (mm)	H (inches)
Vibration Damper 4 1/2" CF	96.5	3.80
Vibration Damper 6" CF	101	3.97
Vibration Damper 8" CF	110	4.33
Vibration Damper 10" CF	113	4.45
Vibration Damper 63 ISO	84	3.31
Vibration Damper 100 ISO	84	3.31
Vibration Damper 160 ISO	88	3.46
Vibration Damper 200 ISO	88	3.46

Turbo Vent Valve

The Turbo Vent Valve, consisting of a control unit and a valve, is a complete unit for automatic venting of the Turbo pump when it is switched off or during a power failure. The valve is a normally open, electromagnetically-actuated valve with a filter on the air inlet. The control unit is powered by the Turbo controller and is provided with a fixed delay time of about 5 seconds to avoid undesired venting during a temporary power failure and to allow closure of the system valves before venting.

For ordering information, see individual controllers.

Turbo Vent Device

To control the venting of the Turbo pumps when they are switched off or during a power failure, a vent device is offered. The Turbo vent device consists of a normally closed valve and a control unit. The valve is electromagnetically-actuated and has a filter on the air-inlet. The control unit is powered by the Turbo controller and has a built-in battery backup. Delay and venting times are adjustable up to 36 minutes to optimize the venting conditions for each application.

For ordering information, see individual controllers.

Handheld Terminal

The handheld terminal is a remote control display for use with V 81 series Turbo pumps when connected to a controller without a front panel. It consists of an LCD alphanumeric display and keyboard which provide useful real time indications of the operating conditions and parameters of the turbopump.

Moreover, it allows the reprogramming of the controller parameters and troubleshooting of the pump and controller. The handheld terminal is connected to and powered from the Turbo-V controller through a 1.5 meter cable.

For ordering information, please call your local Agilent Office.

Purge Valve

To protect the bearings of a turbomolecular pump used with aggressive process gases, a measured supply of inert gas (N₂, Ar) must flow into the pump body around the upper bearing toward the fore-vacuum line. The Agilent fixed orifice purge valve is calibrated for nitrogen to provide the correct gas flow to safely operate Turbo pumps. For ordering information, see individual pumps.

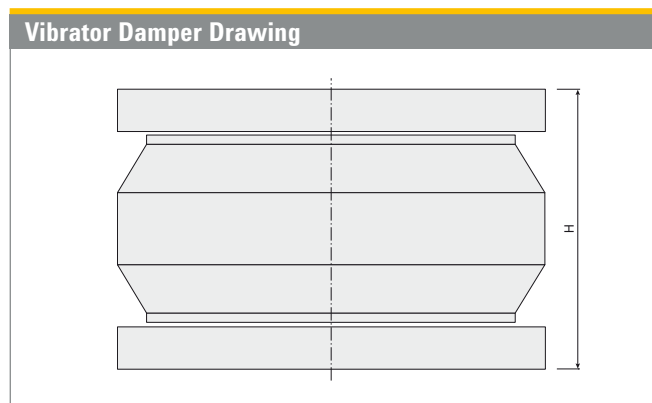

Vibration Level

Thanks to low vibration, focused design, and computer assisted balancing tools, today turbomolecular pumps generate very low levels of mechanical vibration. This is mainly a result of the numerical modeling of the pump rotodynamics (see Figure 1) and a specific vibration damping system already built into the pump structure. Thanks to both design features, today ceramic ball bearings pumps are standard even in very high vibration applications like SEM and Metrology Tools.

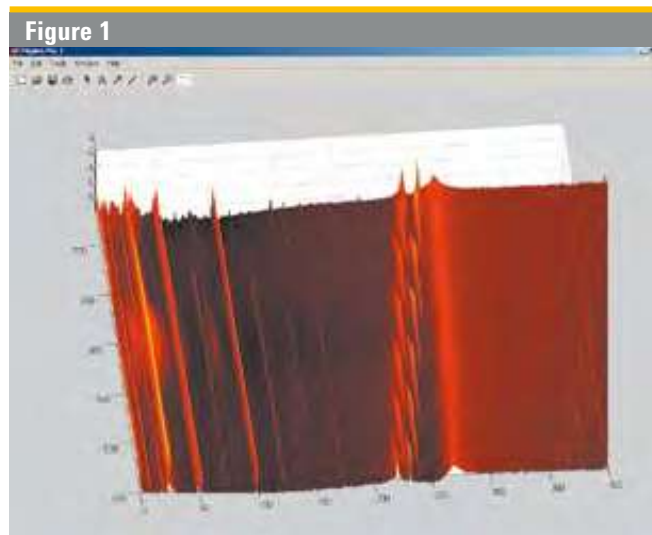

A typical vibration spectrum of a turbomolecular pump can be seen in Figure 2:

Possible sources of vibration in a turbomolecular pump are unbalanced rotor, high frequency motor or bearings. Rotor unbalance can be reduced to a very low level through dynamic balancing, which minimizes forces caused by a nonsymmetric distribution of masses in relation to the rotational axis. As an order of magnitude, the radial displacement on the pump HV flange after balancing can be as low as 0.001 μm .

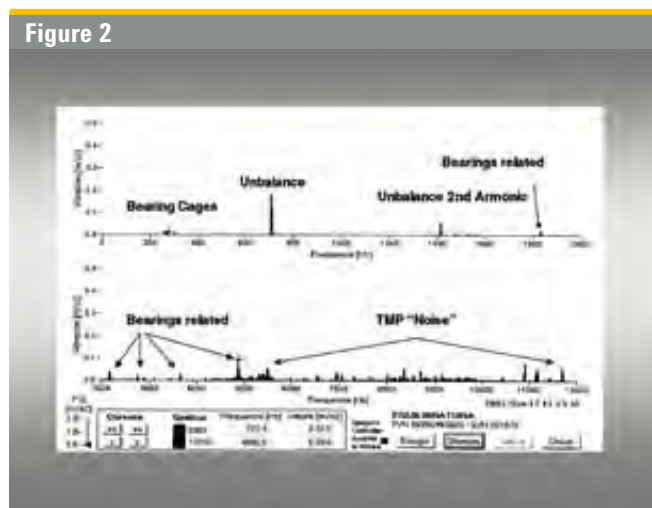

The vibrations from a high frequency motor are caused by electromagnetic interactions between the motor stator and rotor: their characteristic frequencies are multiples of the motor driving frequency. Also, the rotor supports generate both white noise and vibrations at specific frequencies of the bearings' moving parts (cage, balls and rotating ring, usually the inner one).

In general, the vibrations caused by an electric motor or bearing are even lower than those caused by unbalance. They may be relevant in the case of bearing damage or because of excitation of a natural resonant frequency of the system connected to the pump. In the second case, the system structure should be modified by adding mass, changing the stiffness and/or inserting a vibration damper between pump and system.

Operation in Presence of Magnetic Fields

Magnetic fields induce eddy currents in the turbomolecular pump rotor that tend to oppose its rotation. As a consequence the power delivered to the electrical motor is increased.

Since the pump rotor is not in contact with the stator, all the heat generated by the eddy currents must be dissipated by radiation, so the rotor can be overheated even if the static parts remain cool.

According to our tests, the maximum magnetic field that our pumps can tolerate is:

- 50 Gauss in the transversal direction
- 100 Gauss in the axial direction

In these cases, a power increase to the motor can be expected.

If the magnetic field is greater than the above values a shield must be used in order to have a residual magnetic field around the pump below the value specified.

Please contact Agilent for more details.

Turbomolecular Pump Bearings and Lubrication System

The Turbo-V pumps incorporate Agilent's innovative ceramic bearing design with a proprietary ultra-low vapor pressure solid lubricant, which enables these pumps to provide a long service life and a high degree of cleanliness under most operating conditions. This lubrication system is a superior feature of Agilent Technology and guarantees no contamination of the vacuum system, especially when compared to other oil-lubricated turbomolecular pumps (See figures 3-4).

The ceramic bearings utilize balls made of silicon nitride, a polycrystalline material with an amorphous intergranular binder base that offers the following advantages:

Hardness

This is a critical aspect of bearing design, and it closely relates to bearing performance and reliability. The silicon nitride material used in Agilent's Turbo-V bearing system is twice as hard as conventional steel providing dramatic improvement in wear resistance while minimizing the effects of surface contact and stress.

AGILENT TURBO PUMP TECHNICAL NOTES

Figure 3 - Typical Competitor Pump

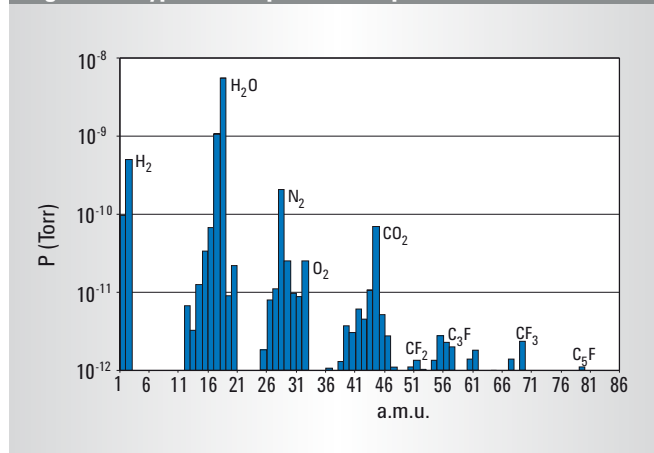
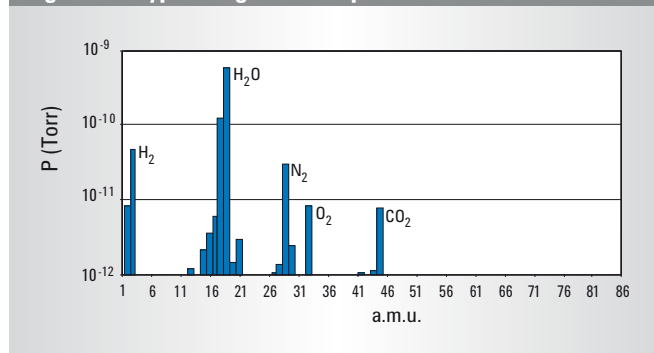

Figure 4 - Typical Agilent Pump



Weight

Silicon nitride is 40% less dense than conventional steels, which helps to reduce centrifugal loading and stress levels at high rotational speeds, especially in the bearing race area.

Friction

Silicon nitride's low coefficient of friction enhances wear resistance and adds to the bearing's operational life.

Thermal Stability

With its low thermal expansion coefficient, the silicon nitride bearing material ensures that tight tolerances and mating component fit will be maintained over an extremely wide temperature range. In addition, silicon nitride has an outstanding resistance to fracture by thermal shock.

Chemical Stability

Silicon nitride is virtually inert.

Another feature of the Turbo-V bearing system is its proprietary lubricant which has an extremely low vapor pressure and is virtually hydrocarbon free. The use of this lubricant in the permanently sealed bearing system ensures clean, reliable operation without the need for any maintenance whatsoever.

Agilent T-plus

Agilent T-plus (Turbo Pumps Linked User Software) is the new communication, control and monitoring software for Agilent Turbomolecular Pumps and all other Agilent products featuring the Agilent Window Serial Protocol.

With T-plus, you can simultaneously drive and control one or more Turbo Pumps, connected to a PC through an RS232 or an RS485 serial communication.

Automatic identification of the connected Pumps, description of each command always on screen, and User Interface adaptable to the Pump Status are only some of the new features developed to make the approach to pump settings easy and to reduce the number of steps during pump configuration.

Moreover, special care is given to the GUI (Graphical User Interface), to reproduce the environment of well-known User Interfaces (such as Microsoft Windows applications), to obtain a real User Friendly tool, and to reduce the user learning time.

T-plus software features several options like Data Logging, Chart Representation and Network Configuration, to help you configure your Vacuum devices quickly, and to check your vacuum system status at any time.

Exhaustive online Help is also included, providing the user with a complete, easy to learn system, tailored to customer requirements.

The previous software release Navigator 2.2 is included in the T-plus CD.

Figure 5

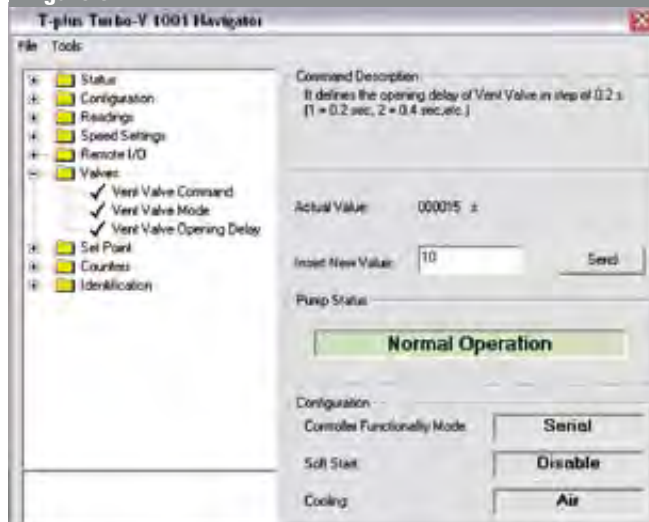

CE/CSA, EMC Electrical Specifications Compliance

Compliance to these norms guarantees that there are no limits on the use of the controllers and turbopumps in every type of ambient, and that their use doesn't create any kind of disturbance to electronic units connected to the same line.

Agilent's new generation of Turbo controllers comply with the limits given by the following norms:

EN 55011 Class A group 1

EN 61000/3/2

EN 61000/3/3

EN 61000/4/2

EN 61000/4/3

EN 61000/4/4

EN 61010-1

UNI EN 291-1

UNI EN 292-2

EN 1012-2

AGILENT TURBO PUMP SERVICE AND SUPPORT PLANS

Agilent Vacuum Products offers one of the most comprehensive service and support plans in the industry. As a worldwide, first class company we strive to offer added value to our Customers wherever they may be located. Excellence in Service and Support is a key factor in added value. Support can be accomplished with qualified Engineers and an appropriate logistic infrastructure.

Technical skills and infrastructure are two areas where we are continuously making medium and long-term investments. Our daily customer support philosophy is focused on two important factors: fast response and no hassle.

This philosophy translates to the following sections of our Turbo Pump Service and Support Plan:

- **Worldwide Parts Sourcing Plan:**
Three Progressive Levels of Support
- **Technical Assistance:** Customer Support, Application Support, Application Training

Agilent Vacuum **Products is committed** to providing our Customers with the most comprehensive service plans possible.

The following pages detail the standard sections of our Turbo Pump Service and Support Plan. For more information, or if you have a need for customized solutions, please contact your Agilent representative.

Often, excellent products are not enough: Agilent's constant presence with Customer Service as a responsive partner is what really makes a difference.

Worldwide Parts Sourcing Plan

- **Repair Program**
Agilent products offer unmatched reliability, performance and cleanliness. Production requirements, however, inevitably create, over time, the need for maintenance and repair. Timely repair at Agilent will keep your products performing at an outstanding level all the time.

- **Advanced Exchange Program**

To maximize uptime, and for those occasions where time is essential, Agilent offers exchange units for advance shipment.

Exchange units are fully remanufactured to the same strict standards as new products. They are kept in stock in North America, Europe, China, Japan, Korea, Singapore, Taiwan and India.

As soon as requested, your Exchange unit can be shipped for overnight delivery. This efficiency is due to our logistic infrastructure and is the result of excellent teamwork among our Service and Customer Service Teams!

The Exchange and Repair Programs are available worldwide and allow global OEMs and End-Users consistent delivery time, value pricing, consistent part numbers, and simple order processing procedures.

- **Upgrade Program**

The Upgrade Program is designed for customers who need to replace an Agilent (formerly Varian) product at the end of its life, or of old technology, with a newest technology product. For example, a customer may wish to replace a Turbo-V250 with our Turbo-V301 Navigator.



TURBO PUMPS

The Upgrade Program includes proactive technical installation support, by telephone and full 12-month warranty.

Agilent's Turbo pump Upgrade Program provides a customer with the same outstanding support delivered with our service programs, including:

- RMA# tracking
 - Replacement with remanufactured pump of the newest technology
 - Advance replacement
 - 24-hour expedited order management
 - WEB on-line order status & shipment tracking
- **End User Extended Warranty**

The End User Extended Warranty is a Service Agreement that provides coverage extension beyond the standard 12 months warranty of a product. It extends for additional 12 months the coverage from failures due to defects in material and workmanship.

By extending the warranty of purchased products, post-sales satisfaction is guaranteed. This is the result of the relevant cost decrease while cost predictability is increased.

The End User Extended Warranty has been designed to cover the needs of the End User Market:

- General Purpose Vacuum applications.
- High Energy Physics Ultra High Vacuum applications.

Ordering Information for End User Extended Warranty

General Purpose Vacuum Applications	Part Number
Extd. Warranty 12M Turbo 80 l/s class	EW81
Extd. Warranty 12M Turbo 300 l/s class	EW300
Extd. Warranty 12M Turbo 700 l/s class	EW700
Extd. Warranty 12M Turbo 1000 l/s class	EW1000
Extd. Warranty 12M Turbo TV1KG	EWTV1KG
Extd. Warranty 12M Turbo TV2KG	EWTV2KG
Extd. Warranty 12M Turbo TV3KG	EWTV3KG
Extd. Warranty 12M Turbo (other config.)	EW969TMP
High Energy Physics UHV Applications	Part Number
Extd. Warranty HEP 12M Turbo 80 l/s class	EW969TV81
Extd. Warranty HEP 12M Turbo 300 l/s class	EW969TV301
Extd. Warranty HEP 12M Turbo 700 l/s class	EW969TV701
Extd. Warranty HEP 12M Turbo 1000 l/s class	EW969TV1001
Extd. Warranty HEP 12M Turbo V2300	EW969TV2300
Extd. Warranty 12M Turbo (other config.)	EW969TMP

- **Cleaning Service**

Agilent offers a cleaning service in cases where a turbo pump may have been exposed to chemically hazardous materials.

This service is available worldwide and allows global OEMs and End-Users consistent delivery time, pricing, part numbers, and order processing procedures.

Ordering Information for Agilent's Cleaning Service

Turbo-V Pump Size	Part Number
From V 60 to TwisTorr 304 FS	TURBOCLEAN1
From V 450 to V 701 Navigator	TURBOCLEAN2
From V 1000 to 3K-G / 2300 TwisTorr	TURBOCLEAN3

AGILENT TURBO PUMP SERVICE AND SUPPORT PLANS

Technical Assistance

As an Agilent Customer, you can rely on an attentive and professional support staff, dedicated to providing you with the easiest and most personalized service solution possible.

Customer Support

- Our toll-free lines, with mother tongue Technical Support Engineers at worldwide locations, allow us to provide you with quick responses to your needs.
- All issues are entered into our data-base, and become available to all Agilent's Technical Support Centers and to our R&D Departments for possible product improvements.

Americas

North America: Toll-Free +1 800-882-7426
Fax +1 781-860-5437

Central and South America: Tel. +1 781-861-7200
Fax +1 781-860-5437

Asia

Japan: Toll-Free +81 120-477-111
Fax +81 120-880-598

Korea: Toll-Free 080-222-2452
Fax +82 (0) 2-3452-3947

China: Beijing Office Toll-Free 800-820-3278
Fax +86 (0)10-6439-2765
Shanghai Office Toll-Free 800-820-3278
Fax +86 (0)21-6628-5169
Guangzhou Office Toll-Free 800-820-3278
Fax +86 (0)20-8669-5861
Shenzhen Office Toll-Free 800-820-3278
Fax +86 (0)755-8276-3181

Taiwan: Toll-Free 0800-018-768

Singapore: Toll-Free 1800-276-2622

Malaysia: Toll-Free 1800-880-805

India Toll-Free 1800-1801-517

Europe and Israel

Austria, Belgium, Finland, France, Germany, Holland, Ireland, Israel (*), Italy, Portugal, Spain, Switzerland, UK:

Toll-Free 00-800-234-234-00

Toll-Free-Fax 00-800-345-345-00

(*) From Israel dial 012 instead of initial 00

Other Countries

Tel. +39 011-9979-369

Fax +39 011-9979-330



Application Support - Application Training

- Our Application Engineers can bring Agilent's expertise in vacuum technology to our customers
- Application Support is a project-based activity where our experts assist you solving the application issues that might arise pre-sales or post-sales
- By designing solutions that meet customer needs, Agilent aims at creating a positive and synergetic relationship with customers
- Our experts keep you up-to-date on industrial and scientific vacuum applications with the goal of optimizing the use of our products on your system



AGILENT TPS TURBO PUMPING SYSTEMS

2-4	Features and Benefits
5	Typical Applications
6-7	Mini-TASK AG81
8-9	TPS-compact
10-11	TPS-bench
12-13	TPS-mobile



Agilent Technologies

AGILENT TPS

INTEGRATED PUMPING SOLUTIONS, NOW AVAILABLE WITH TWISTORR 304 FS

Powered by Agilent Turbomolecular pumps, featuring the new TwisTorr 304 FS, and backed by Agilent Dry Scroll or Rotary Vane Pumps.

Mini-TASK AG81

Portable, dry system with the smallest footprint.

TPS-compact

Turbo-V 81 or TwisTorr 304 FS: best vacuum performance, fast pumpdown time, integrated IDP-3 Dry Scroll Pump.

TPS-bench

Table-top solutions, backed by Agilent Dry Scroll Pump or Rotary Vane Pump.

TPS-mobile

Roll-around carts, high capacity systems, wide pumping speed range, now also available with the state-of-the-art IDP-15 Dry Scroll Pump.

Customized configurations on request



IDP-3 Dry Scroll Pump

- The most compact and light scroll pump in the market
- Innovative hermetic design, with motor and bearings outside the vacuum space
- Integrated pump isolation valve
- Cost effective and easy tip-seal replacement



Design for Reliability

- A rigorous test regime of product performance, reliability and durability according to Agilent standards
- Environmental Test method (Shock, Humidity, Noise, Temperature, Vibration Tests)
- Reliability assessment on Agilent systems
- Vacuum Test, Life Tests



Manufacturing

- New TPS Manufacturing Line in Agilent Vacuum Products plant in Torino, Italy

Service and Support

- Several levels of Service Programs to help you maximize your productivity: Advance Exchange, Upgrade Program, Factory Repair, Field Support

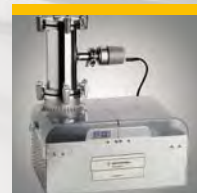

Active Gauge Capability

- FRG-700 Active Full Range combined gauge: Pirani and Cold Cathode from atmosphere to 5×10^{-9} mbar (7×10^{-9} Torr)
- Pressure data available on three independent channels:
 - Serial communication
 - Analog output
 - On board display

TPS TURBO PUMPING SYSTEMS

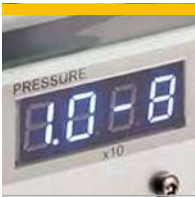

On Board Direct Pressure Reading

- Large pressure reading display
- Torr, Pascal and mbar options
- Ready for FRG-700 Active Gauge

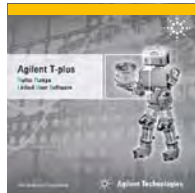

User-friendly Interface

T-Plus software for full PC/Laptop control enables easy data download and graphic display.



NOW AVAILABLE WITH THE NEW IDP-15 DRY SCROLL PUMP

Turbo Pumping Systems

TwisTorr FS Technology

High Performance, Innovation, Reliability



Agilent

Floating Suspension, to ensure:

- Low vibration and acoustical noise
- Extended bearings operating life
- Exceptional stability for demanding applications



Unique TwisTorr stages

to deliver the best vacuum performance available:

- High pumping speed and compression ratio
- High throughput, high foreline tolerance
- Low power consumption, low operating temperature



AGILENT TPS

INTEGRATED PUMPING SOLUTIONS, NOW AVAILABLE WITH TWISTORR 304 FS

The new TPS Turbo Pumping Systems: just plug and pump!

Portable, fully integrated vacuum solutions, available as light dry bench-top solutions, for small and medium volumes, or high capacity, wide pumping speed range cart versions.

Now available with the innovative, breakthrough TwisTorr FS technology, for outstanding performance and reliability.

Turbo Pumping Systems: key features

Integrated, complete vacuum systems

- Wide range from bench-top to cart versions
- Flexible: broad choice of gauges, valves and components
- Compact and portable: small footprint, light weight
- Enhanced, reliable vacuum performance
- Easy-to-use, simply plug and pump!
- Cost-effective solutions
- Worldwide power configurations and safety standards
- Global Technical, Application and Customer Service support
- Advance Exchange, Upgrade and Repair programs available
- Dry versions: no hydrocarbon contamination, no oil leaks
- **Improved reliability with the new TwisTorr FS pumps**

Innovative Vacuum Technologies for Your System



Agilent Turbo Pump Technology

- Wide pumping speed range from 67 to 600 l/sec
- TwisTorr 304 FS: the innovative molecular-drag technology
- Outstanding reliability
- Highest compression ratio and pumping speed



Agilent Dry Scroll Pumps

- No maintenance required, simple tip seal replacement
- CE, CSA certified
- Isolation valve integrated/included
- IDP-3: the smallest scroll pump in the market; pumping speed 3.0 m³/h, and ultimate pressure 3.3 x 10⁻¹ mbar
- SH-110: pumping speed 5.4 m³/h



Agilent Rotary Vane Pumps

- Wide pumping speed range from 1.8 to 20.5 m³/h
- Dual stage
- Forced oil circulation
- Gas ballast valve
- Anti-suckback valve and vent device



High Energy Physics and Research Centers

This new TPS Turbo Pumping System may be used in any laboratory where there is a need to create high vacuum in small-volume chambers quickly and easily.

The new generation electronics and the pressure display ensure the accuracy of the process.

Agilent TPS are well suited for UHV System pump down, Ion pump roughing, High Vacuum Systems operation, High and Ultra High Vacuum systems bake out.



Electron Microscopy and Mass Spectrometry

The new TPS Integrated Turbo Pumping System are the perfect tool to keep the column of an electron microscope under vacuum while performing maintenance or repair on the device.

The oil-free nature of the dry systems guarantees freedom from contamination of the column.

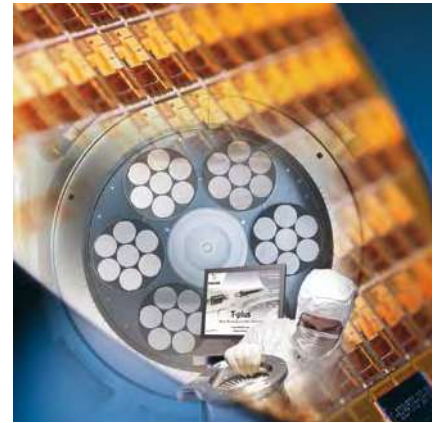

Industrial Applications

The Agilent TPS Turbo Pumping Systems can create and maintain the required vacuum level in separate chamber of an industrial system during maintenance or repair.

The TPS with Dry Scroll Pumps are particularly well suited for evacuating load-lock chambers, or in Medical Accelerators applications.

Their oil-free design ensures the purity of the process.

The Mini-TASK may be mounted in any position, making it suitable for most system.

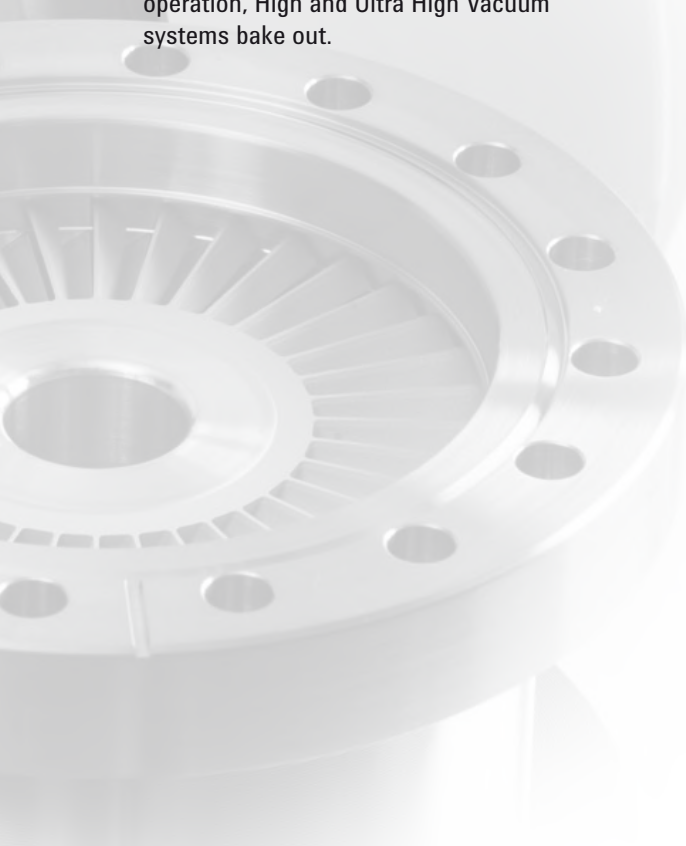

AGILENT TPS TURBO PUMPING SYSTEMS MODELS

▶ Agilent Mini-TASK AG81

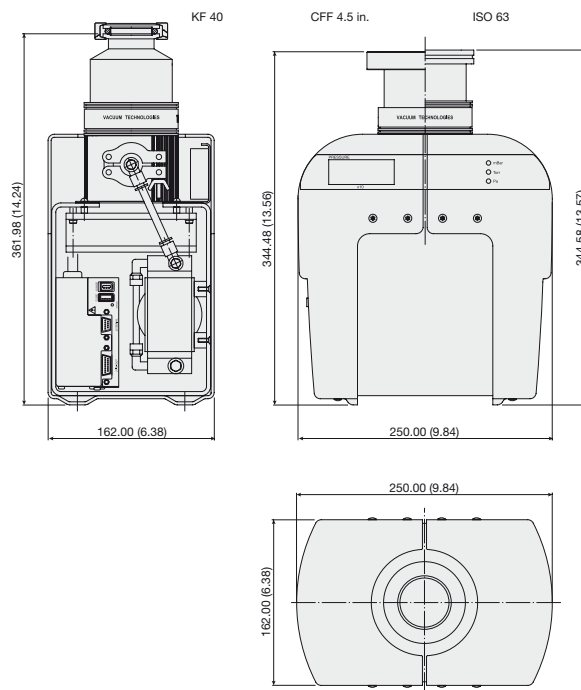

Dimensions: millimeters (inches)

A small and compact, easy-to-use, integrated dry vacuum system, featuring the Agilent Turbo-V 81 MacroTorr pump with top vacuum performance, backed by a dry 10 l/min diaphragm pump. It can operate in any position, and does not require maintenance. Active Gauge capability, large pressure display, T-Plus Navigator Software to connect to your PC. Universal voltage (90-240 V), CE/CSA certified.

Features

- New generation turbomolecular pump Turbo-V 81-M
- Compact, light, dry, clean and robust system
- Universal voltage (90-240 V) - CE/CSA certified
- RS-232 or analogical communication
- Vacuum gauge driving card
- Large pressure data display
- Pressure driven set point, analog set point

Benefits

- Designed for demanding applications
- Cost-effective pumping solution for small volumes
- Can be used world-wide
- Easy to use: plug and pump system
- Compatible with world-wide power configurations
- Complies with world-wide safety standards
- Easy system pressure measurement

Technical Specifications

Flange		KF40	ISO63	CFF 4.5 in.
Pumping speed (l/s)	N ₂	40	60	60
	H ₂	36	40	40
	He	45	55	55
Base pressure		2 x 10 ⁻⁷ mbar	2 x 10 ⁻⁷ mbar	5 x 10 ⁻⁸ mbar*
Bakeout temperature		80 °C at inlet	80 °C at inlet	120 °C at inlet
Shipping weight		7.5 kg (16.4 lbs)	7.5 kg (16.4 lbs)	8.3 kg (18.3 lbs)
Pumpdown time (1 liter volume)		60 sec. to 24 mbar; 120 sec. to 1 x 10 ⁻⁴ mbar; 160 sec. to 7 x 10 ⁻⁵ mbar		
Turbo pump rotational speed		80,000 rpm		
Start-up time		Less than 2 minutes		
Operating position		Any		
Operating ambient temperature		5 °C to 35 °C / 32 °F to 122 °F		
Input Voltage and frequency		90V to 240V AC; 50 Hz / 60 Hz		
Maximum input power		220 VA		
Serial communications		RS-232, 9-pin D-type, T-Plus Software		

* According to standard DIN 28 428.

TPS TURBO PUMPING SYSTEMS

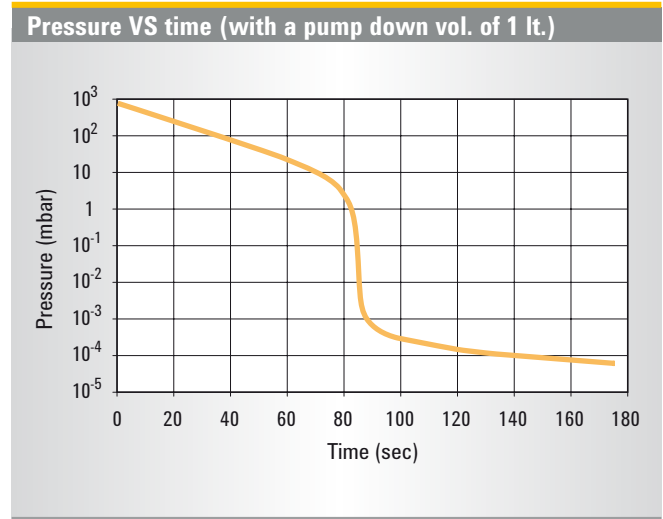
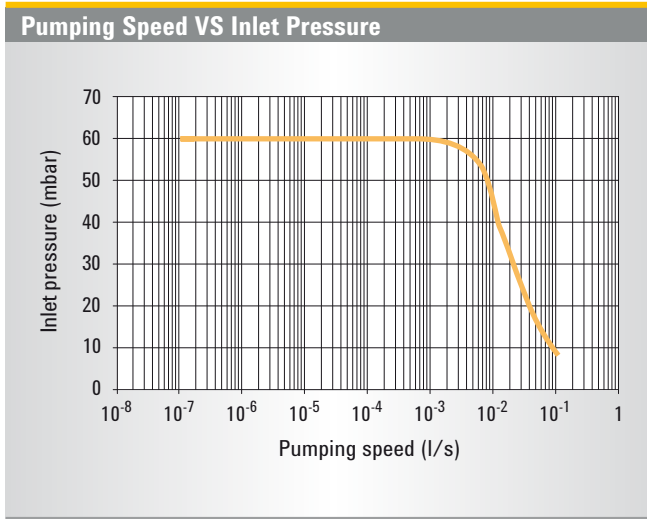

Ordering Information

Mini-TASK AG81	KF40	ISO63	CFF 4.5 in
	G8703A#020	G8703A#021	G8703A#022

Accessories

DIY Full Range Gauge Kit*	9699190	9699192	9699193
EU plug power cable**, 2 meters (1 ph)	9499396	9499396	9499396
USA plug power cable**, 2 meters (1 ph)	9499397	9499397	9499397
UK plug power cable**, 2 meters (1 ph)	9499398	9499398	9499398
Serial Cable and T-Plus Navigator Software	9699883	9699883	9699883

NOTE Special Vent Valve available on request

* The DIY Gauge Kit can be ordered separately, and includes Full Range Gauge FRG-700, Cable for gauge connection, Vacuum Tee and Connecting Hardware (Flanges according to the System inlet flange)

** Power Cord to be ordered separately

AGILENT TPS TURBO PUMPING SYSTEMS MODELS

▶ Agilent TPS-compact



A portable, fully Integrated, hydrocarbon-free pumping system powered by the Turbo-V 81M or by the innovative TwisTorr 304 FS pumps, backed by the unique Agilent 60 l/min IDP-3 Dry Scroll, new generation primary pump.

A cost-effective pumping solution with large pressure display, Active Gauge capability, universal voltage (90-240 V), CE/CSA certified.

TPS-compact with Turbo-V 81M – ISO 63

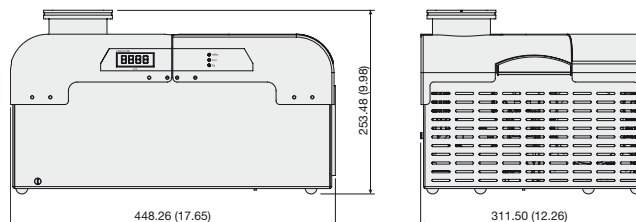

TPS-compact with TwisTorr 304 FS – ISO 100

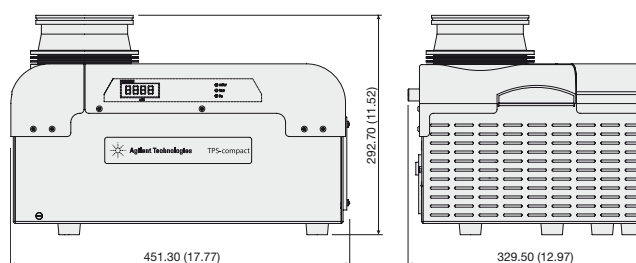

Dimensions: millimeters (inches)

Features

- Available with TwisTorr 304 FS or Turbo-V 81 Turbomolecular Pumps
- IDP-3 Dry Scroll backing pump
- Compact, light, dry, clean and robust system
- Nominal voltage (90-240 V) - CE/CSA certified
- RS-232 or analogical communication
- Vacuum gauge driving capability
- Large pressure data display
- Pressure driven set point, analog set point
- Wheels option available

Benefits

- Designed for demanding applications
- Cost-effective pumping solution
- Easy to use: plug and play system
- Complies with world-wide safety standards
- Easy system pressure measurement
- Easy Tip-seal replacement (10 min)
- Excellent base pressure up to 10^{-9} mbar
- Easy to be moved in small space

Technical Specifications

	Equipped with TV 81M	Equipped with TwisTorr 304 FS
Pumping speed	N_2 : 77 l/s	N_2 : 180 l/s (with inlet screen)*
Base pressure**	1×10^{-9} mbar (CFF flanges) - 1×10^{-8} mbar (ISO flanges)	1×10^{-9} mbar (CFF flanges) - 1×10^{-8} mbar (ISO flanges)
Pumpdown time (15 lt volume)	80 sec (100 mbar); 110 sec (1 mbar); 155 sec (1^{-4} mbar); 400 sec (1^{-5} mbar)	80 sec (16 mbar); 110 sec (3 mbar); 155 sec (6×10^{-5} mbar); 200 sec (1×10^{-5} mbar)
Turbo pump rotational speed	80,000 RPM	60,000 RPM
Start-up time	15 sec.	15 sec.
Operating ambient temperature	5 °C to 35 °C	5 °C to 35 °C
Input voltage and frequency	115 Vac 60 Hz or 220-240 Vac 50/60 Hz	115 Vac 60 Hz or 220-240 Vac 50/60 Hz or 100 Vac 50/60 Hz
Maximum input power	260 VA	310 VA
Bakeout temperature	120 °C at inlet (CFF flanges) - 80 °C at inlet (KF/ISO flanges)	120 °C at inlet (CFF flanges) - 80 °C at inlet (ISO flanges)
Communication	RS232 - Analogical I/O	RS232 - Analogical I/O
Weight	16.7 kg (36.8 lbs)	20.1 kg (44.3 lbs)

* Pump nominal speed: TwisTorr 304 FS N_2 : 250 l/s

** According to standard DIN 28 428.

TPS TURBO PUMPING SYSTEMS

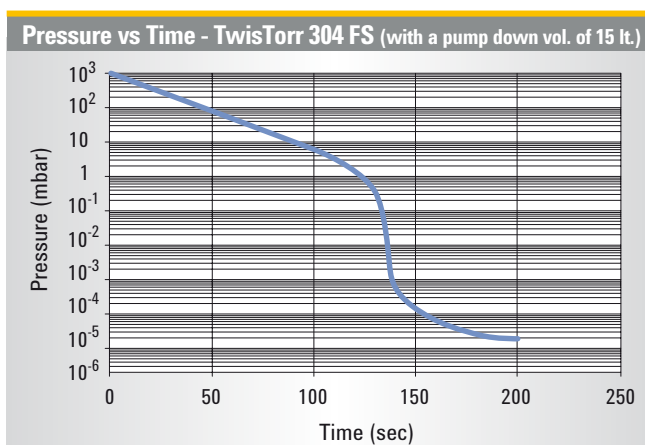
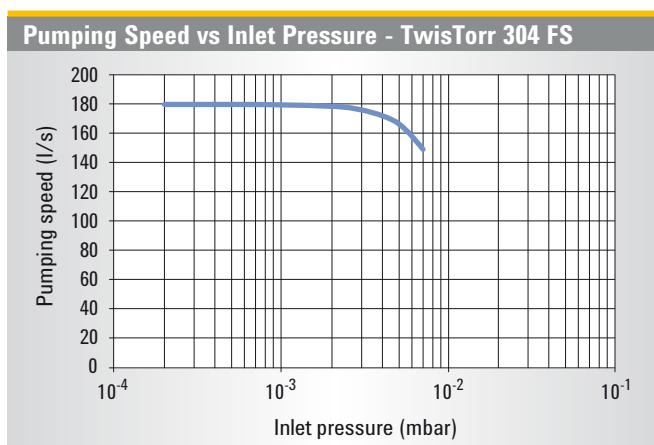
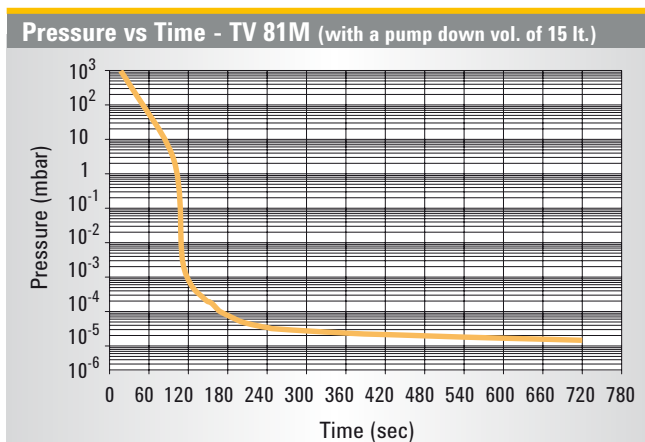
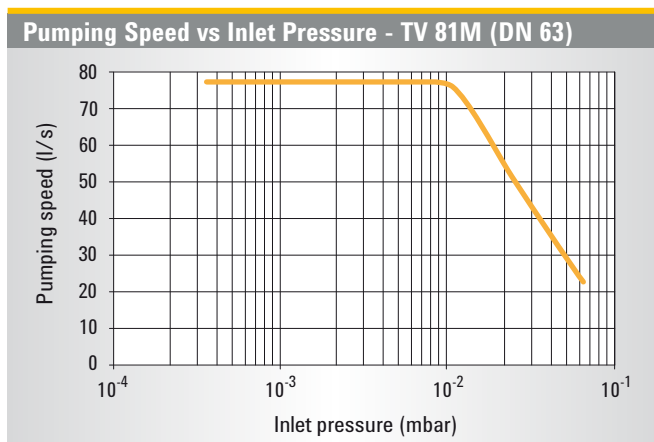

Ordering Information

TPS-compact TV 81M	KF40	CFF 2 3/4"	ISO 63	CFF 4 1/2"
105 V*	G8702A#010#020#105	G8702A#010#027#105	G8702A#010#021#105	G8702A#010#022#105
120 V	G8702A#010#020#120	G8702A#010#027#120	G8702A#010#021#120	G8702A#010#022#120
220 V	G8702A#010#020#220	G8702A#010#027#220	G8702A#010#021#220	G8702A#010#022#220

Accessories

DIY Full Range Gauge Kit**	9699190	9699199	9699192	9699193
----------------------------	---------	---------	---------	---------

TPS-compact TwisTorr 304 FS	ISO 100	CFF 6"	ISO 160	CFF 8"
105 V*	X3580A#011#023#105	X3580A#011#024#105	X3580A#011#025#105	X3580A#011#026#105
120 V	X3580A#011#023#120	X3580A#011#024#120	X3580A#011#025#120	X3580A#011#026#120
220 V	X3580A#011#023#220	X3580A#011#024#220	X3580A#011#025#220	X3580A#011#026#220

Accessories

DIY Full Range Gauge Kit**	9699194	9699201	9699195	9699202
----------------------------	---------	---------	---------	---------

NOTE Special Vent Valve available on request

* For Japanese market

** The DIY Gauge Kit can be ordered separately, and includes Full Range Gauge FRG-700, Cable for gauge connection, Vacuum Tee and Connecting Hardware (Flanges according to the System inlet flange)

Other Accessories

Wheels accessory kit	9698233	EU Power cord (5 m)	9698450
EU Power cable (2 m)	9499396	US Power cord (5 m)	9698452
US Power cable (2 m)	9499397	UK Power cord (5 m)	9698451
UK Power cable (2 m)	9499398	Serial Cable and T-Plus Navigator Software	9699883

AGILENT TPS TURBO PUMPING SYSTEMS MODELS

▶ Agilent TPS-bench



**TPS-bench with
TV 81M and DS 42**

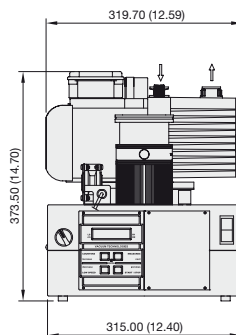

**TPS-bench with
TV 81M and IDP-3**

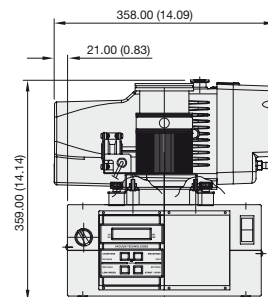

**TPS-bench with
TwisTorr 304 FS and DS 102**

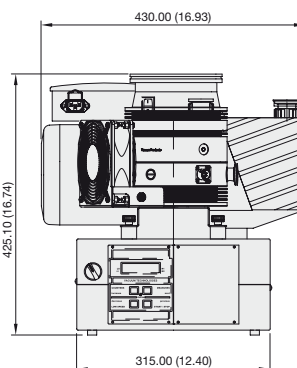

**TPS-bench with
TwisTorr 304 FS and DS 302**

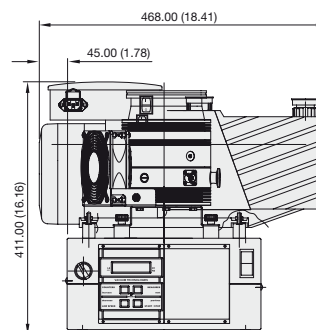

**TPS-bench with
TwisTorr 304 FS and SH110**

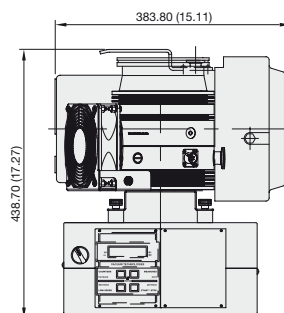

Depth: 453 (17.83)

Dimensions: millimeters (inches)

Table-top, compact and reliable vacuum solutions. 80 possible standard configurations with the Turbo-V 81M and the new TwisTorr 304 FS Turbo Pumps, backed by Agilent Dry Scroll and Rotary Vane Pumps. Gauges and accessories available. T-Plus Software, and Isolation valve integrated/included. Voltage 110/230V. CE, UL/CUL, CSA and Semi S2-0200 certified. Applications include UHV System pump down, Ion pump roughing, Lamp and tube processing, Cryopump regeneration, High Vacuum Systems operation, High and Ultra High Vacuum systems bake out.

Turbomolecular Pumps - Pumping Speed

	Turbo-V 81M DN 63	TwisTorr 304 FS ISO 100, CFF 6"
Pumping speed	N ₂ : 77 l/s	N ₂ : 180 l/s (with inlet screen)*

* Pump nominal speed: TwisTorr 304 FS N₂: 250 l/s

Base Pressure*

	Turbo-V 81M	TwisTorr 304 FS
Base Pressure with SH110 Dry Scroll Pump	5 x 10 ⁻⁹ mbar (3.8 x 10 ⁻⁹ Torr)	< 1.0 x 10 ⁻¹⁰ mbar (< 7.5 x 10 ⁻¹¹ Torr)
Base Pressure with DS-102 Rotary Vane Pump	5 x 10 ⁻¹⁰ mbar (3.8 x 10 ⁻¹⁰ Torr)	< 1.0 x 10 ⁻¹⁰ mbar (< 7.5 x 10 ⁻¹¹ Torr)

* According to standard DIN 28 428

TPS TURBO PUMPING SYSTEMS

Pumpdown Time*

Pumpdown time (15 liter volume) 40 sec (45 mbar); 60 sec (7 mbar); 80 sec (5×10^{-1} mbar); 100 sec (8×10^{-5} mbar); 115 sec (1×10^{-5} mbar)

* TPS-bench with TwisTorr 304 FS ISO 100 and SH 110 Scroll Pump

TPS-bench standard configurations

TPS-compact	TV 81M KF40	TV 81M ISO 63	TV 81M CFF 2 3/4"	TV 81M CFF 4 1/2"	TwisTorr 304 FS ISO 100	TwisTorr 304 FS CFF 6"	TwisTorr 304 FS ISO 160	TwisTorr 304 FS CFF 8"
DS 42 - 120 V	•	•	•	•				
DS 42 - 220 V	•	•	•	•				
DS 102 - 120 V	•	•	•	•	•	•	•	•
DS 102 - 220 V	•	•	•	•	•	•	•	•
DS 202 - 120 V	•	•	•	•	•	•	•	•
DS 202 - 220 V	•	•	•	•	•	•	•	•
DS 302 - 120 V	•	•	•	•	•	•	•	•
DS 302 - 220 V	•	•	•	•	•	•	•	•
IDP-3 - 120 V	•	•	•	•				
IDP-3 - 220 V	•	•	•	•				
SH 110 - 120 V	•	•	•	•	•	•	•	•
SH 110 - 220 V	•	•	•	•	•	•	•	•

Ordering Information available on request: call Agilent for details

Turbomolecular Pumps

Turbo Pump Model	Inlet Flange
Turbo-V 81M	ISO 63, KF 40*, CFF 2 3/4", CFF 4 1/2"
TwisTorr 304 FS Pump	ISO 100, CFF 6", ISO 160, CFF 8"

* Configuration available on request

Primary Pumps

Dry Scroll Pumps	Peak Pumping Speed 50 Hz
SH 110, single phase	90 l/min - 5.4 m ³ /h - 3.3 cfm
IDP-3, single phase	50 l/min - 3.0 m ³ /h - 1.8 cfm

Rotary Vane Dual Stage Pumps	Pumping Speed 50 Hz
DS 42 - 1 phase worldwide motor	2.3 m ³ /h
DS 102 - 1 phase worldwide motor	5.0 m ³ /h
DS 202 - 1 phase worldwide motor	8.3 m ³ /h
DS 302 - 1 phase worldwide motor	11.6 m ³ /h

Managing Gauges

GAUGE KIT	Inlet Flange	DIY FRG-700 Full Range Gauge Kit (atmosphere to 3.8×10^{-9} Torr)
Turbo-V 81M	KF 40	9699190
	ISO 63	9699192
	CFF 4 1/2"	9699193
TwisTorr 304 FS	ISO 100	9699194
	CFF 6"	9699201

For other gauge configurations, please contact your local Agilent representative.

Cables

Power cords are included free of charge in all TPS-bench and TPS-mobile models, with US, EU or UK plug.

AGILENT TPS TURBO PUMPING SYSTEMS MODELS

▶ Agilent TPS-mobile



TPS-mobile with TwisTorr 304 FS and SH110

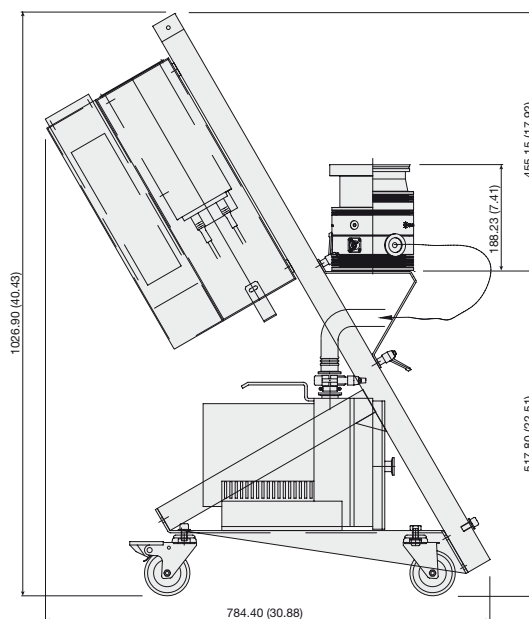

Depth: 453 (17.83)

Dimensions: millimeters (inches)

Roll-around cart, high capacity systems, with higher compression ratio and wide pumping speed range. 168 possible configurations, with the Agilent Turbo-V 81M, the new TwisTorr 304 FS, the Turbo-V 551 Navigator Pumps, backed by Dry Scroll Pumps (including the new IDP-15) or DS Mechanical Pumps. Gauges and accessories available for customized solutions.

T-Plus Software, Isolation valve integrated/included. Voltage 110/230V. CE, UL/CUL, CSA and Semi S2-0200 certified.

Applications include UHV System pump down, Ion pump roughing, Lamp and tube processing, Cryopump regeneration, High Vacuum Systems operation, High and Ultra High Vacuum systems bake out.

Turbomolecular Pumps - Pumping Speed

	Turbo-V 81M DN 63	TwisTorr 304 FS ISO 100, CFF 6"	Turbo-V 551 Navigator DN 160
Pumping speed	N ₂ : 77 l/s	N ₂ : 180 l/s (with inlet screen)*	N ₂ : 550 l/s (with inlet screen)

* Pump nominal speed: TwisTorr 304 FS N₂: 250 l/s

Base Pressure*

	Turbo-V 81M	TwisTorr 304 FS	Turbo-V 551 Navigator
Base Pressure with SH110 Dry Scroll Pump	5 x 10 ⁻⁹ mbar (3.8 x 10 ⁻⁹ Torr)	< 1.0 x 10 ⁻¹⁰ mbar (< 7.5 x 10 ⁻¹¹ Torr)	< 1.0 x 10 ⁻¹⁰ mbar (< 7.5 x 10 ⁻¹¹ Torr)
Base Pressure with DS-102 Rotary Vane Pump	5 x 10 ⁻¹⁰ mbar (3.8 x 10 ⁻¹⁰ Torr)	< 1.0 x 10 ⁻¹⁰ mbar (< 7.5 x 10 ⁻¹¹ Torr)	< 1.0 x 10 ⁻¹⁰ mbar (< 7.5 x 10 ⁻¹¹ Torr)

* According to standard DIN 28 428

TPS TURBO PUMPING SYSTEMS

Pumpdown Time*

Pumpdown time (15 liter volume) 40 sec (50 mbar); 60 sec (8 mbar); 80 sec (7×10^{-1} mbar); 100 sec (1×10^{-4} mbar); 130 sec (1×10^{-5} mbar)

* TPS-mobile with TwisTorr 304 FS ISO 100 and SH 110 Scroll Pump

TPS-mobile standard configurations

TPS-compact	TV 81M KF40	TV 81M ISO 63	TV 81M CFF 2 3/4"	TV 81M CFF 4 1/2"	TwisTorr	TwisTorr	TwisTorr	TwisTorr	TV 551	TV 551	TV 551	TV 551
					304 FS ISO 100	304 FS CFF 6"	304 FS ISO 160	304 FS CFF 8"	ISO 160	CFF 8"	ISO 100	CFF 6"
DS 42 - 120 V	•	•	•	•								
DS 42 - 220 V	•	•	•	•								
DS 102 - 120 V	•	•	•	•	•	•	•	•				
DS 102 - 220 V	•	•	•	•	•	•	•	•				
DS 202 - 120 V	•	•	•	•	•	•	•	•				
DS 202 - 220 V	•	•	•	•	•	•	•	•				
DS 302 - 120 V					•	•	•	•	•	•	•	•
DS 302 - 220 V					•	•	•	•	•	•	•	•
DS 402 - 120 V					•	•	•	•	•	•	•	•
DS 402 - 220 V					•	•	•	•	•	•	•	•
DS 602 - 120 V					•	•	•	•	•	•	•	•
DS 602 - 220 V					•	•	•	•	•	•	•	•
IDP-3 - 120 V	•	•	•	•	•	•	•	•				
IDP-3 - 220 V	•	•	•	•	•	•	•	•				
SH 110 - 120 V	•	•	•	•	•	•	•	•				
SH 110 - 220 V	•	•	•	•	•	•	•	•				
IDP-15 - 120 V					•	•	•	•	•	•	•	•
IDP-15 - 220 V					•	•	•	•	•	•	•	•
TS 300 VPI - 120 V					•	•	•	•	•	•	•	•
TS 300 VPI - 220 V					•	•	•	•	•	•	•	•
TS 600 VPI - 120 V					•	•	•	•	•	•	•	•
TS 600 VPI - 220 V					•	•	•	•	•	•	•	•

Ordering Information available on request: call Agilent for details

Turbomolecular Pumps

Turbo Pump Model	Inlet Flange
Turbo-V 81M	ISO 63, KF 40*, CFF 2 3/4", CFF 4 1/2"
TwisTorr 304 FS Pump	ISO 100, CFF 6", ISO 160, CFF 8"
Turbo-V 551 Navigator	ISO 100, CFF 6", ISO 160, CFF 8"

* Configuration available on request

Primary Pumps

Dry Scroll Pumps	Peak Pumping Speed 50 Hz
IDP-3, single phase	50 l/min - 3.0 m ³ /h - 1.8 cfm
SH 110, single phase	90 l/min - 5.4 m ³ /h - 3.3 cfm
TriScroll 300, single phase, with Vacuum Pump Isolation Valve (VPI)	220 VAC 210 l/min 2.6 m ³ /h - 7.4 cfm
TriScroll 600, single phase, with Vacuum Pump Isolation Valve (VPI)	220 VAC 420 l/min 25.2 m ³ /h - 14.8 cfm
IDP-15, single phase	214 l/min - 12.8 m ³ /h

Rotary Vane Dual Stage Pumps

	Pumping Speed 50 Hz
DS 42 - 1 phase worldwide motor	1.8 m ³ /h
DS 102 - 1 phase worldwide motor	5.0 m ³ /h
DS 202 - 1 phase worldwide motor	9.6 m ³ /h
DS 302 - 1 phase worldwide motor	11.6 m ³ /h
DS 402 - 1 phase worldwide motor	17.4 m ³ /h
DS 602 - 1 phase worldwide motor	30.2 m ³ /h

AGILENT TPS TURBO PUMPING SYSTEMS MODELS

Agilent TPS-mobile (Cont'd)

Managing Gauges

GAUGE KIT	Inlet Flange	DIY FRG-700 Full Range Gauge Kit (atmosphere to 3.8×10^{-9} Torr)
Turbo-V 81M	KF 40	9699190
	ISO 63	9699192
	CFF 4 1/2"	9699193
TwisTorr 304 FS	ISO 100	9699194
	CFF 6"	9699201
Turbo-V 551 Navigator	ISO 160 K	9699195
	CFF 8"	9699202

For other gauge configurations, please contact your local Agilent representative.

Cables

Power cords are included free of charge in all TPS-bench and TPS-mobile models, with US, EU or UK plug.



AGILENT LEAK DETECTION

- 2-3 The Agilent Advantage
- 4-22 Leak Detection Instruments
- 23-27 Accessories and Options
- 28-29 Global Support Network
- 30-31 Training
- 32-33 Advantages of Helium Leak Detection
- 34-35 Leak Detection Methods
- 36-39 Typical Applications
- 40-41 Design and Application Considerations
- 42-43 Technical Notes



Agilent Technologies

AGILENT LEAK DETECTION

The Agilent Advantage

Rigorous standards in today's manufacturing and research and development environments require complete leak detection solutions. The *Agilent Advantage* offers a comprehensive solution the primary component of which is our commitment to Maximize your Productivity and Uptime.

Key components of The Agilent Advantage:

- Global Applications Support
- High Performance Instruments
- Industry Leading Service and Support

High Performance Instruments

VS Series

- Easy, two button operation with fully automated start-up and calibration
- Color touch screen display allows users to program several test parameters
- Can select from several languages and measurement units
- Available with wireless remote



VS C15

- The most compact, easiest to integrate component system available – more than 50 % smaller than competitive systems
- Only 2 cables, power and communications
- Comprehensive interface options – serial, analog, discrete I/O and Profinet
- Selectable sensitivity scales and Contra-Flow vacuum design for fast, accurate measurements with maximum protection from contamination in industrial applications



959 Leak Detector

- Rugged, easy to use, idea for many industrial applications
- Single button test activation, automatic pump down and transfer into test mode
- Vacuum testing at high inlet pressures – up to 1 Torr – shortens time-to-test
- Auto-protection from test port overpressure, power failures and operator errors
- Wet and dry versions available



PHD-4

- Sensitivity and portability in a very economical package
- Easy to use – no training required
- Battery power, and light weight (2.6 kg (5.7lbs)), make it ideal for field maintenance applications



LEAK DETECTION



Global Applications Support

Expertise When & Where You Need It

- Toll-free hotlines provide easy accessibility to live, front-end support
- Worldwide customer service representatives assist you with order status, pricing and delivery, and service information
- Native language applications specialists available locally, worldwide
- Application specific consulting
- More than ten thousand installed systems delivering application solutions to customers in a broad range of industries

*Maximize
Your
Productivity
and System
Uptime*



Industry Leading Service and Support

Get the Most from Your Investment

- Extensive network of service engineers available to meet your needs
- Flexible, comprehensive service plans provide service and support for years of trouble-free operation
- Services include applications assistance, start-up support, vacuum and leak detection training, comprehensive maintenance, service agreements, and warranty extensions
- Competent Technical support engineers are to respond with technical product data, troubleshooting, and literature

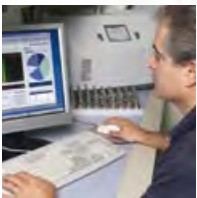

Application Notes and White Papers

Our offering of technical information guides you to the most appropriate leak detection method or system design for your specific application.

- Application notes are available at no cost
- Agilent handbooks on leak detection principles, operation, and techniques



Complete Line of Vacuum Pumps

Agilent is a Total Vacuum Solutions provider, offering a comprehensive choice of vacuum pumps.

- Rotary vane and dry scroll primary pumps
- Turbo/drag high vacuum pumps
- Specifically designed for leak detection applications
- See page 22 and dedicated sections of the Agilent catalog for more information

PUMP SPECIFICATIONS

	Mass Spectrometers					
	Portable		Bench Mount		Mobile	
	VS PR02	VS PD03	VS BR15	VS BD30	VS MR15	VS MD30
Primary pumps	DS 42 RVP	Dry pump combo	DS 302	TriScroll 620	DS 302	TriScroll 620
Nominal pumping speed (m ³ /hr (l/min))	2 (34)	3 (50)	14 (232)	30 (500)	14 (232)	30 (500)
Sensitivity ranges (atm cc/sec)	5 x 10 ⁻¹²					
Minimum detectable leak*	5 x 10 ⁻¹² atm cc/sec; 5 x 10 ⁻¹² mbar l/s; 5 x 10 ⁻¹³ Pa m ³ /sec					
Maximum test port pressure	Gross leak mode: 200 mbar, 150 Torr, 20,000 Pa Test mode: 13 mbar, 10 Torr, 1,330 Pa					
Calibration	Automated or Manual (Internal or External)					
Background suppression	Push Button Initiated Auto Zero, and Auto Zero < Zero Function					
Communication interface	RS232 and analog (standard), Discrete IO (optional)					
Set points	5 Set Points Standard, N/O or N/C; 3 Leak Rate, 1 Pressure, 1 Audio					
Remote Display/Control	Wireless Remote Control (Optional)					
Shipping weight - base unit (kg (lbs))	63 (140)	57 (125)	75 (165)	83 (183)	105 (230)	114 (250)
Compliance to Norms	CE, UL/CSA					

*Per AVS 2.1



VS PR02



VS MR15



VS MD30

LEAK DETECTION

		Selective Ion Pump Detector
Mobile 959	Component VS C15	Portable Sniffer PHD-4
Dry Scroll or Rotary Vane	N/A	Diaphragm Pump
Options as required	Options as required	–
1×10^{-4} through 1×10^{-8}	4 working ranges covering 1×10^{-3} to 1×10^{-9} atm cc/sec	–
2×10^{-9} atm cc/sec	5×10^{-10} atm cc/sec	5×10^{-6} atm cc/sec 5×10^{-6} mbar l/s 5×10^{-7} Pa m ³ /sec
1 Torr	5 Torr, 7 mbar, 667 Pa	–
Manual	Automated or manual (internal or external)	–
Manual	Auto zero, and auto zero < zero function	Automatic/Manual
Analog	RS232, analog, discrete IO, and Profinet	Standard Analog and RS-232 Serial Output
–	5 set points: 4 leak rate and/or pressure, 1 audio	–
–	Optional	–
23 (50)	Base Unit: 9 (19.8)	2.6 (5.7)
–	UL/CSA, CE Approved	CE, CSA/US



959

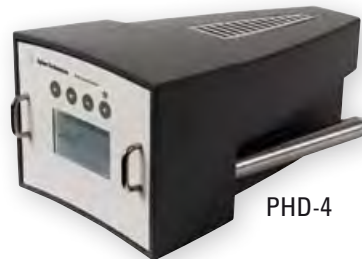

PHD-4



VS C15

AGILENT LEAK DETECTION INSTRUMENTS

▶ Agilent VS Series

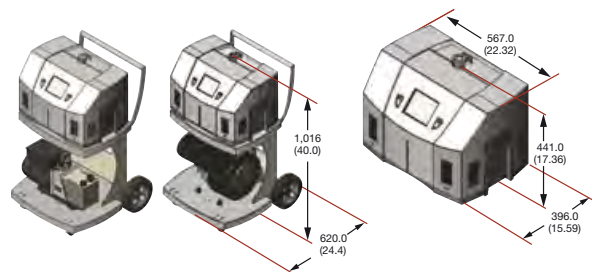

Dimensions: millimeters (inches)

VS Series leak detectors combine the simplicity of two-button operation with advanced system intelligence. Start and vent buttons permit simple day-to-day operation. User-friendly software offers intuitive navigation to vast system capabilities. Programmable test sequences simplify daily operation, minimize operator error, and maximize production efficiency. The TFT-style touch screen features high definition and brightness with wide viewing angles.

Setup for worldwide use, these leak detectors can be operated in multiple languages – English, French, German, Spanish, Korean, Japanese and Chinese – and units of measure. And the VS Series conforms to CE, UL and CSA standards, assuring global acceptance.

VS Series leak detectors employ Agilent's primary pumps – rotary vane or scroll – and high vacuum pumps that deliver high inlet pumping speed and inlet pressure tolerance, minimizing test cycle time and maximizing production throughput.

State-of-the-art spectrometer and vacuum system design enable a broad range of test methods for specific applications. The high efficiency ion source and beam optics optimize sensitivity and mass separation, giving the VS Series very high sensitivity to meet the most stringent leak test requirements. At the same time, these leak detectors enjoy high test port pressure tolerance which permits detection of large leaks.

In addition, high helium pumping speed ensures fast system response and clean-up times.

Primary pump and system mounting options may be selected to best suit application requirements and test environments, and the compact, lightweight design enables easy transport from one application to another. Robust design innovations allow the VS Series to conform to the most rigorous industrial standards and operate dependently in the most challenging environments.

Technical Specifications

Model Number	PR02 & PD03	MR15 & MD30
Configuration options	Portable	Mobile
Primary pump type	Rotary vane pump Dry scroll pump	DS-42 2 m ³ /hr (34 l/m) DS-302 14 m ³ /hr (232 l/m) Dry pump combo 3 m ³ /hr (50 l/m) TS-620 30 m ³ /hr (500 l/m)
Minimum detectable leak at 1000 ppm ambient helium	5 x 10 ⁻¹² atm cc/sec: 5 x 10 ⁻¹² mbar l/s: 5 x 10 ⁻¹³ Pa m ³ /sec helium	
Maximum test port pressure	13 mbar, 10 Torr, 1330 Pa	
Helium pumping speed @ test port (fine test)	1.8 l/s	
Calibration routine	Automated or manual (internal or external)	
Background suppression	Push button initiated auto zero, and auto zero < zero function	
User interface	High clarity, color display, TFT touch screen	
Selectable languages	English, French, German, Japanese, Korean, Mandarin, Spanish	
Automated cycling	Programmable rough time, test time, reject set points	
Response time	< 0.5 seconds	
Set points	Standard, 5 set points, N/O or N/C; 3 leak rate, 1 pressure, 1 audio	
Communications interface	RS232 and analog (standard), Discrete IO (optional)	
Conformance standards	UL/CSA, CE	

Ordering Information

VS Models	
Description	Ordering Instructions
VS PR02 Portable Leak Detector, 2 m ³ /hr rotary vane pump	Choose Product Number G8600A
VS PD03 Portable Leak Detector, 3 m ³ /hr dry scroll pump combo	Choose Product Number G8600B
VS MR15 Mobile Leak Detector, 15 m ³ /hr rotary vane pump	Choose Product Number G8601A
VS MD30 Mobile Leak Detector, 30 m ³ /hr dry scroll pump	Choose Product Number G8601B
VS BR15 Bench Mount Leak Detector, 15 m ³ /hr rotary vane pump	Choose Product Number G8602A
VS BD30 Bench Mount Leak Detector, 30 m ³ /hr dry scroll pump	Choose Product Number G8602B

Additional Options (Add Option Number to Product Number as desired)

Description	Ordering Instructions	Benefit
Oil Mist Eliminator for DS42 RVP	Add Option Number #100	Reduces oil vapor in pump exhaust.
Discrete IO Interface	Add Option Number #101*	Allows control and monitoring via PC or PLC. 12 outputs permit total control of the instrument and 6 inputs allow recording of key test data.
Wireless remote, base unit	Add Option Number #102	Allows communication with wireless hand-held remote control, ordered separately (p/n VSLDWRC).
Nitrogen vent	Add Option Number #103	Allows the VS leak detector to be vented with nitrogen or other gas of the users preference. Maximum supply pressure 2 PSI (0.14 bar). Requires user supplied overpressure protection.
1 ½ inch compression testport	Add Option Number #104	For customers who prefer the old-style 1 ½ in. compression fitting on the leak detector inlet.
Test fixture cable	Add Option Number #105*	For customers who wish to add a test fixture and test initiation switch. Requires Discrete IO Interface, ordered separately (p/n VSFACIO).

* Option #101 is required when Option #105 is ordered. Example: G860xx#101#105.

Accessories (Ordered Separately)

Description	Part Number	Benefit
Power probe, NW25	K9565306	Rugged sniffer probe for testing of sealed containers pressurized with helium; adjusts for varying sensitivity and response time.
Helium spray probe	K0167301	Allows spraying of helium to find the exact location of a leak. Includes three nozzle types for different application requirements.
Wireless remote (hand held unit)	G8600-60002	Brings all major functions of the leak detector to the user's fingertips, enabling a truly portable solution at up to 100 meters.
External calibrated leaks	F8473xxx (see page 23 for details)	Leak traceable to NIST standards for precise calibration of your leak detector.
Tuning leaks	K1608301 R1947301	Ten segment calibrated needle valve to aid gross leak testing.
Universal test fixture (Flapper box)	L6241xxx (see page 25 for details)	This accessory makes testing of small parts very fast and almost totally automatic.
Leak Test Data Wizard	VSLTDW	Comprehensive, user-friendly data management software enables automation of basic leak test processes, tracks data history, and provides graphical display of leak test data.
Harsh environment (HE) probe	G8600-68002	Designed to withstand the wet environment and high temperatures inside condenser piping without the need for dryers, chillers, a secondary vacuum pump, or throttling valves.

AGILENT LEAK DETECTION INSTRUMENTS

▶ Agilent Wireless Hand-Held Remote Control



Leaks in large systems often occur far from the leak detector. Wired remote controls have sought to address this problem but impedance and the cumbersome nature of long cables are often limiting factors, so in many applications these traditional wired remotes offer little benefit.

Agilent is proud to introduce the first wireless remote control for a helium mass spectro-meter leak detector. By utilizing modern wireless technology, leak testing hard-to-reach locations is now much easier, and can be performed at much greater distances of up to 100 meters.

Applications in large systems in which two technicians were previously required can now be performed by one technician, thereby reducing labor costs. All the major functions of the leak detector are now at your fingertips giving you a truly portable leak detection solution.

In addition to the visual bar graph of the leak rate, the remote control has a speaker that provides a variable tone indicating the trend and relative size of the leak. The wireless remote can operate for a full 8-hour shift, or longer, on four AA batteries and conforms to ISM band, 2.4 GHz FHSS standards.

Applications

- Vacuum Furnaces
- Glass Coaters
- Roll Coaters
- E-Beam Welders
- Beam Lines/Accelerators
- Semiconductor Process Tools
- Ion Implanters
- Power Generation Plants

Features

- Wireless technology
- 100 meter (328 ft) range
- Internal speaker
- Head phone jack
- 20 channels
- 2.4 GHz frequency, ISM band compliant

Benefits

- Significantly extends range without cumbersome, restrictive cables
- Enables single operator testing
- Emits variable tone that corresponds to leak rate signal
- Enables testing even in noisy environments
- Allows use of hand held remote with multiple leak detectors
- Free license band with minimum cross-talk

Technical Specifications

Frequency/Band	2.4 GHz, ISM Band FHSS Compliant
Range	100 m (328 ft)
Functions	Test/Hold, Zero, Read standard leak, Set-up
Power supply	4 (four) AA batteries, Alkaline or rechargeable (not included)
Operating life	Approximately 12 hrs (dependent on batteries)
Internal speaker	85 dB min @ 1.0 ft
Head phones	Mono, 3.5 mm plug, ≥ 32 ohm impedance, 1000-10,000 Hz frequency response
Operating temperature	+12 °C to +40 °C
Ruggedness	Meets industrial standards for hand-held equipment (Section 8.4.2 of UL 61010-1 2nd edition)

Ordering Information

Description	Shipping Weight kg (lbs)	Part Number
VS Wireless Remote Controller	0.5 (1.0)	G8600-60002
VS Wireless Remote Control Base Unit Kit (field installed). Also available as a factory installed option on VS leak detectors - order Option 102	0.5 (1.0)	G8600-68001

▶ Leak Test Data Wizard for VS Series Leak Detectors



Capturing and analyzing leak test data are increasingly critical to the leak test process. Aggressive manufacturing yield and efficiency targets, demanding quality control procedures, and ISO and regulatory compliance requirements have created a need for a capable, user-friendly data management tool. To meet this need, Agilent has designed the Leak Test Data Wizard, a comprehensive data management software package for use with our VS Series mass spectrometer leak detectors. The Leak Test Data Wizard is a flexible PC based, graphic-rich tool that makes full use of the data from the VS leak detector to customize automation of basic leak test processes, assuring testing uniformity over time or between operators. Messages can be created that guide your operators step-by-step through your testing process. Once a specific test is developed for a particular part or system, it can be saved and recalled for future use. Results from leak tests are graphically displayed in easy to read formats to provide individual part test histories, or to clearly identify trends in high volume test applications. All this can be accomplished without costly third party support.

Features

- Data recording and plotting mode
- Multiple parts testing mode
- Four reject set points with custom messaging capability
- Background test set-up function
- Leak test library
- Graphical display of test results in easy to read formats

Benefits

- Stores and plots leak rate vs. time and pressure vs. time data for analysis
- Basic automation of a leak testing process without the need for third party support
- Custom messages guide operator through step-by-step process
- Identify bad parts early in the testing cycle
- Allows access to previous test set-ups
- Clearly track trends during the testing process

Ordering Information

Description	Shipping Weight kg (lbs)	Part Number
Leak Test Data Wizard	0.2 (0.5)	VSLTDW

▶ Agilent Harsh Environment Probe for Helium Leak Detection



Power generation facilities, chemical plants and similar facilities require a leak detector to sample gas that is primarily water vapor (steam) and/or contains chemicals that would damage the detector. To prevent this damage from happening, Agilent has developed a specialized probe and leak detector configuration tailored to the demanding requirements of these applications.

The VS Harsh Environment (HE) Probe is designed to withstand the wet environment and high temperatures inside condenser piping without the need for dryers, chillers, a secondary vacuum pump, or throttling valves. The probe can either be held or installed in the exhaust of a pump on the condenser system, or can be flange-mounted directly into the piping of the system under test. The probe is connected to the flange via an adjustable compression fitting so the probe tip can be positioned in the center of the pipe. This guarantees the probe tip is in the maximum helium flow for the best sensitivity.

Equipment damage due to corrosion or water in the leak detector or roughing pump is eliminated. The Agilent HE Probe is able to withstand water, amines (ammonia derivatives), and operate at temperatures up to 95 °C (200 °F). The probe is connected directly to a VS Leak Detector with no additional water trapping or auxiliary pumping required. The probe consists of a corrosion resistant 316L stainless steel tube with a composite permeable membrane at its tip. The membrane readily permeates helium tracer gas while protecting the leak detector from water vapor and chemicals that would destroy the pumps, valves, and spectrometer. When the HE Probe is used in conjunction with an Agilent VS Leak Detector equipped with a wireless remote, the manpower needed for a leak test can be cut in half. A single operator can spray helium remotely from the location where the detector is sampling gas, yet can still monitor the instrument's response.

Applications

-
- Power generation
 - Chemical plants
 - Process gas piping
-

LEAK DETECTION

Features

- Permeable membrane technology
- Can be inserted directly into the center of the pipe
- Extremely durable
- Easy to use
- Economical

Benefits

- Prevents water and chemicals from contaminating and damaging the leak detector
- Faster response time and better sensitivity
- Withstands hot, wet, corrosive environments
- Simple system connection. No maintenance or adjustments
- Less expensive than dryers and repeated purchases of sacrificial pumps

Technical Specifications

Operating temperature range	+10 °C (+50 °F) to +95 °C (+200 °F)
Storage temperature range	-18 °C (0 °F) to +65 °C (+150 °F)
Operating vacuum pressure	Atmospheric pressure to low vacuum 1μ Hg, <1 ⁻³ mbar/Torr, 1 ⁻¹ Pa
Maximum internal overpressure	1 Bar, (14.7 PSI), (105 Pa)
Probe length	450 mm (17.7") Hose High density polyethylene, 5 meters (16.4') long
Weight of probe assembly	0.5 kilogram (1 pound)
Hose fitting size	½" (12.7 mm) Swagelok™ compression or equivalent
Vacuum flanges	ISO KF25
Adaptor flange o-ring	Butyl rubber, Parker B2-016 or equivalent
Chemical resistance	Probe resists virtually all chemicals except complex halogenated compounds

Ordering Information

Description	Shipping Weight kg (lbs)	Part Number
Harsh Environment (HE) Probe	2.0 (5.0)	G8600-68002

VS SERIES FEATURES AND BENEFITS

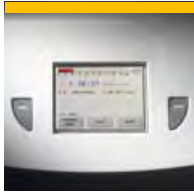

Easy-to-Use – Two Button Operation

VS Series Leak Detectors combine the simplicity of two-button operation with advanced expert system intelligence.

- Fully automated start-up and calibration maximizes productivity
- Intuitive menu structure is easy to navigate
- Programmable test sequences improves testing efficiency
- Color touch screen provides excellent clarity, even at wide angles



Powerful – Broad Range of Test Methods

The state-of-the-art spectrometer and vacuum system design provides powerful capability, enabling a broad range of test methods for specific applications.

- High test port pressure allows for detection of large leaks
- 5×10^{-12} MDL (sensitivity) meets the most stringent leak test requirements
- High helium pumping speed ensures fast system response and clean-up times
- New high efficiency ion source and beam optics optimize sensitivity and mass separation



Versatile – Multiple System Configurations

A wide range of options allows for broad configuration flexibility, meeting all application requirements and test environments.

- Primary pump and system mounting options may be selected to best suit your needs
- Multiple language and units capability permits easy implementation worldwide
- Compact lightweight design enables easy transport from one application to another



Dependable – Robust Design

Robust design innovations allow the VS series to conform to the most rigorous industrial standards and operate dependably in the most challenging environments.

- Fast clean-up time enhances system up-time
- Robust Faraday cup technology delivers proven reliability with low cost of ownership
- Conforms to CE, UL and CSA standards, assuring global acceptance

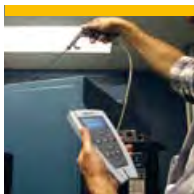

Truly Portable – Wireless Remote Control/Display

Hand-held remote performs essential functions up to 100 meters (328 feet) indoors, facilitating access to all leak sites.

- Eliminates cumbersome cables while extending range
- Allows testing of large systems by a single operator
- Leak detector can be located outside cleanroom to prevent contamination
- Multiple channels for use of one remote with up to ten leak detectors

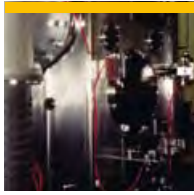

Industrial Process Tools

VS Series Leak Detectors can help rid your process tool of costly and inefficient leaks. Robust system features assure reliable operation in the most challenging industrial environments. Superior pumping characteristics such as high inlet pressure tolerance and split flow capability deliver fast response and clean-up times. Wireless remote control enables single-person leak testing of even the largest systems.

- Vacuum furnaces
- Coating systems
- Electronic beam welders



Power Generation

Leaks within power plant condensers can cause a significant loss of efficiency. High inlet pressure tolerance, auto-zero function, and mobility of the two-wheel cart option simplify the leak detection process. Simple, intuitive operation allows intermittent use without excessive training requirements. Wireless remote control with an operating range of 100 meters (328 feet) provides true hand-held portability, enabling leak testing by a single operator. See page 8.

Power generation facilities, chemical plants and similar facilities require a leak detector to sample gas that is primarily water vapor (steam) and/or contains chemicals that would damage the detector. To prevent this damage from happening, Agilent has developed a specialized probe and leak detector configuration tailored to the demanding requirements of these applications. See page 10.

- Condensers
- Heat exchangers
- Steam circuits



High Energy Physics

High sensitivity, large roughing capacity and portability are essential for leak testing accelerators and beam lines. These instruments provide excellent mass separation that differentiates the smallest helium leaks from residual water vapor and hydrogen, and are available with large, dry roughing pumps to evacuate large volumes, or smaller internal pumps when used with turbo pumping systems.

Wireless remote control with an operating range of 100 meters (328 feet) enables a single operator to check potential leak sites without a cord of any kind.

- Accelerators
- Beam lines
- Synchrotrons



Semiconductor Production

VS Series Leak Detectors combine high sensitivity and large, dry rough pumping capacity to meet the testing needs of semiconductor processing equipment and gas handling systems. With the high inlet pressure tolerance and fast clean up and response times, these units excel at locating leaks in both evacuated and pressurized systems. A clean room technician can use the hand-held wireless remote control while the leak detector remains installed in a less critical area.

- Process tools
- Gas panels
- Gas transfer lines

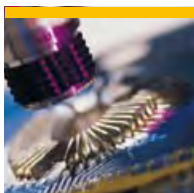

Small Parts Manufacturing

VS Series Leak Detectors employ high inlet pumping speed and high inlet pressure tolerance to minimize test cycle time, thereby maximizing production throughput. Programmable test sequences simplify daily operation, minimize operator error, and maximize your production efficiency. Optional “Leak Test Data Wizard” software can be used to collect data for quality control purposes and even automate test cycles.

- Automotive
- Electrical
- Refrigeration
- Hermetic packaging
- Medical & Implantable devices



General R&D

Research and university labs often require a portable leak detector with the versatility to cover a wide range of applications. The ability to be easily moved from lab to lab, in conjunction with high performance specifications in both the evacuation and pressurized mode, make the VS Series an essential tool for this environment.

- Electron microscopes
- Experimental chambers
- Surface analytical systems
- Space chambers

AGILENT LEAK DETECTION INSTRUMENTS

▶ Agilent VS C15 Component Leak Detector

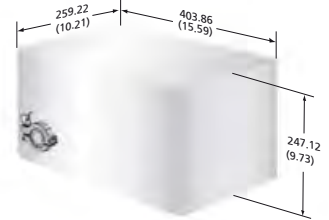
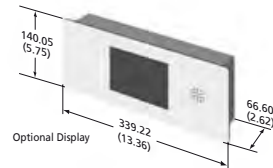

UL/CSA, CE Approved

Dimensions: millimeters (inches)

The VS C15 Component Leak Detector is a simple solution to the complex task of leak detection integration.

- Compact housing minimizes space requirements – everything needed to do the job is located within one box. Over 50% reduction in space when compared to competitive systems
- Simplified interface with only two cables required, one for power, one for communications
- Does not require mounting modules or bulky, expensive interconnecting cables that are found standard in most leak detection systems today
- Most comprehensive array of interface options, including serial, discrete I/O and Profinet. Other interface options to be made available when required.

- Optional color touch screen display allows access to system status information and all operating parameters
- Critical leak detector components are safely housed in a single enclosure protecting them from the industrial environment
- Selectable sensitivity scales and a Contra-Flow vacuum design ensures fast, accurate measurements while maximizing protection from contamination in industrial applications
- Calibrated leak (10^{-7} range) included
- Widest operating temperature range, suitable for warm factory environments.

Technical Specifications

Minimum detectable leak	5×10^{-10} atm cc/sec; 5×10^{-10} mbar l/s; 5×10^{-11} Pa m ³ /sec
Selectable sensitivity ranges	4 working ranges covering 1×10^{-3} to 1×10^{-9} atm cc/sec
Maximum test port pressure	5 Torr, 7 mbar, 667 Pa
Calibration routine	Automated or manual (internal or external)
Background suppression	Auto zero, and auto zero < zero function
Display interface (optional)	High clarity TFT color touch screen
Display – Selectable languages	English, French, German, Spanish, Japanese, Korean, Mandarin
Set points	5 set points: 4 leak rate and/or pressure, 1 audio
Analog output	0-10 V, log 1 V/decade & 2 V/decade and linear (DB-9F)
Serial interface	RS-232 isolated interface @9600 baud (DB-9M)
Discrete I/O	Optically isolated, 5-24 VDC outputs and inputs (DB-25S)
Networking interface (optional)	Profinet I/O option (RJ45)
Power input	24 VDC: $\pm 5\%$; Max current: 4 A (Molex 03-12-1036)
Operating temperature	5 to 48 °C

LEAK DETECTION

Ordering Information

Description	Shipping Weight kg (lbs)	Part Number
VS C15 base unit	9.0 (19.8)	G8603A
Options and accessories		
Display and display cable – 10 ft.	3.5 (7.8)	VSC15DU
Display cable – 10 ft.	0.2 (0.5)	VSCDUC10
24 V external power supply	0.8 (1.7)	VSC15PS
Power cord for power supply – 8 ft.	0.5 (1.0)	VSCBUPC8
ConvecTorr gauge – 1/8 in. NPT	0.5 (1.0)	L9090301
ConvecTorr gauge – NW 16 KF	0.5 (1.0)	L9090305
ConvecTorr gauge – NW 25 KF	0.5 (1.0)	L9090306
Remote gauge cable – 10 ft.	0.2 (0.5)	VSCCTC10
Remote Gauge Cable – 25 ft.	0.2 (0.5)	VSCCTC25
Profinet interface card – factory installed	–	G8603A#300
Profinet interface card – field installed	0.5 (1.0)	VSCFLDPN

For information on Support Plans, refer to page 28.

For information on leak detector options and accessories, refer to page 23 through 27.

For information on roughing pumps, refer to page 22.

AGILENT LEAK DETECTION INSTRUMENTS

▶ Agilent 959

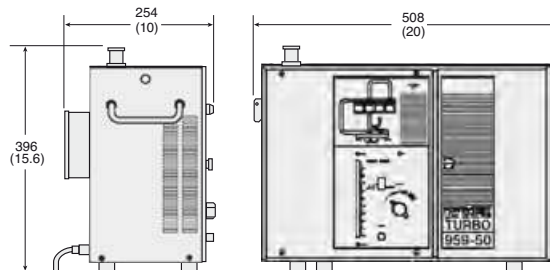

on 2-Wheel Cart

The 959 MacroTorr Helium Leak Detector fulfills the need for a rugged and dependable leak detector in the most demanding industrial applications. With its low price and cost of ownership, this unit is the most cost effective leak detector available. It is available in stand-alone, bench-top, and two-wheel cart configurations. We have designed these units with large externally-mounted primary pumps that deliver high roughing speeds for fast pump down times. The bench-top and cart-mounted versions are available with Agilent DS 302 rotary vane pumps or TriScroll 320 dry pumps.

- External mounting of large primary pumps results in fast pump down cycles
- High test port pressure tolerance reduces time required to reach test mode
- Available in wet and dry versions, on two- or four-wheel carts, or bench-top
- Simple, rugged design provides the cost effective solution for many applications

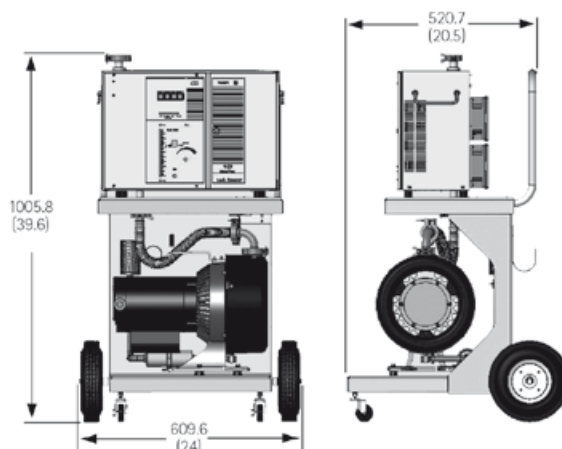

Dimensions: millimeters (inches)

Technical Specifications

Sensitivity ranges	10 ⁻⁴ thru 10 ⁻⁸ atm cc/sec
Minimum detectable leak at 1000 ppm ambient helium	2 x 10 ⁻⁹ atm cc/sec helium
Maximum test port pressure	1 Torr
High vacuum pump	V70D MacroTorr turbo/drag pump
Primary pump type	Rotary vane pump DS 302 Dry scroll pump TS 320
Inlet flange	NW-25 (optional 1 1/8" compression adapter)
Calibration routine	Manual
Background suppression	Manual
Leak indication	50 segment bar graph w/exponent display
Leak units displayed	Atmospheric cc/sec.
Ranging	Manual
Analog leak rate output (plug)	Phone jack, 0-5 VDC
Audio alarm	Threshold and volume control (103 dBA maximum @ 1 ft.) and output jack for remote speaker
Electronic response time	2 seconds
Recommended ambient operating temperature	5 to 35 °C
Power requirements	115 V or 230 V, 50/60 Hz (15/20 amps)
Weight, base unit	22.7 kg (50 lbs)

LEAK DETECTION

Ordering Information

Configuration	Part Number			
	Base	x = Mounting	x = Sensitivity	xxx = Voltage
Stand-Alone (Pumps not Included)*	S9590000xxxxx	• 0 (None supplied)		
Single Rotary Vane Pump DS-302	L9593000xxxxx	• B = Bench • T = Two-wheel	• M = Standard Sensitivity	• 120 • 220
Single Dry Scroll Pump TS-320	D9593500xxxxx	• B = Bench • T = Two-wheel		

Description	Shipping Weight kg (lbs)	Part Number
Accessories and Options		
Sniffer probe, NW25, 10' hose	1.8 (4)	K9565306
Sniffer probe, NW25, 25' hose	1.8 (4)	K9565307
Calibrated leak, external, NW25, 10 ⁻⁷ range (NIST-traceable)	1.8 (4)	F8473321
Calibrated leak, external, NW25, 10 ⁻⁸ range (NIST-traceable)	1.8 (4)	F8473322
Tuning leak/throttle valve, NW25	2.3 (5)	R1947301
Spectrometer tube cleaning kit	1.4 (3)	670029096
Replacement Parts		
O-ring kit	0.9 (2)	L6930301
Ion Source, thoriated iridium	0.1 (0.2)	82850302
Preamplifier, MacroTorr	0.5 (1)	L9030301

* 959 sensitivity is influenced by the speed of the system's primary pump. The above specifications are obtained with a nominal 10 cfm displacement pump.

For information on Support Plans, refer to page 28.

For information on pump options, refer to page 22.

For information on additional accessories and options, refer to pages 23 through 27.

AGILENT LEAK DETECTION INSTRUMENTS

▶ Agilent PHD-4

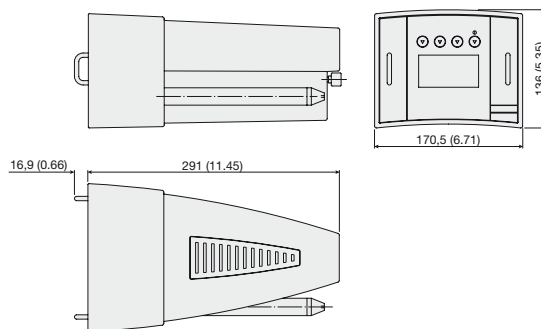

Dimensions: millimeters (inches)

The PHD-4 is a portable, compact leak detector that runs on its own battery for up to four hours. Weighing only 2.6 kg (5.7 lbs) including the battery, it can be taken anywhere. The PHD-4 detects very small leaks in objects that have a slight helium/air pressure inside. It is sensitive to helium concentrations as small as 2 parts per million which equivalent to a leak rate of 5×10^{-6} atm-cc/sec. This level of sensitivity is far superior to the performance of other means of detecting leaks such as bubble testing. To accomplish this it relies on Agilent's proprietary and patented Selective Ion Pump Detection (SIPD) technology.

Controlled by a microprocessor, the PHD-4 is easy to use with no training required. All tuning and zeroing are handled automatically. The display can be set to use any of four languages – English, French, German, and Italian.

The basic PHD-4 package includes:

- PHD-4 basic module
- Transformer/battery charger (115 V-240 V)
- Carrying strap
- 15-pin I/O connector
- Instruction manual on CD-ROM

The complete PHD-4 package includes everything in the basic package plus:

- Spare battery
- Travel case
- Probe set

The PHD-4 replacement kit includes:

- Sampling pump with fittings
- Probe with sampling line
- Probe tip filter
- Internal filter kit (5 units)

Technical Specifications

Lowest detectable helium concentration	2 ppm (parts per million)		
Lowest detectable helium leak	5×10^{-6} mbar l/s	5×10^{-6} atm cc/s	5×10^{-7} Pa m ³ /s
Response time	< 2 sec		
Recovery time	<10 sec (from 50 ppm to 0 ppm)		
Start up time, including self check-up	3 min approx.		
Electrical supply	<ul style="list-style-type: none"> • Rechargeable battery included • Power supply included 110-240 V 50-60 Hz 		
Battery operation time	4 hours		
Maximum signal drift	10 ppm/10 min		
Operating conditions	Temperature: +5 °C to +35 °C Humidity: 90% maximum relative humidity		
Storage conditions	Temperature: -20 °C to +60 °C Weight: 2,6 kg (5.7 lbs)		
Compliance to norms	CE, CSA/US approved		

LEAK DETECTION

Ordering Information

PHD-4 Complete Package	Part Number
Travel Case includes	9694640
• PHD-4 basic unit	
• Spare battery	
• Transformer/Battery charger (110-240 V)	
• Carrying strap	
• Probe set	
• 15-pin I/O connector	
• CD Instruction manual	
PHD-4 Basic Package	Part Number
Includes	9694600
• PHD-4 basic unit	
• Transformer/Battery charger (110-240 V)	
• Carrying strap	
• 15-pin I/O connector	
• CD Instruction manual	
PHD-4 Replacement Part Kit	Part Number
Includes	9694660
• Sampling pump with fittings	
• Probe with sampling line	
• Tip probe filter	
• Internal filter (kit of 5 units)	

Accessories	Part Number
• Probe set	9693515
• Capillary leak with refillable reservoir and gauge	9693540
• Probe with 10 meter (30') maximum sampling line	9693525
• Telescoping extension probe	9693520
Individual Replacement Parts	Part Number
• Spare battery	SR03702609
• Power supply (110-240 V)	SR03702888
• Sampling pump with fittings	SR03702513
• Probe with sampling line	SR03702538
• Tip probe filter	SR2890001201
• Internal filter (kit of 5 units)	SR03702959
• Carrying strap	SR03702791
• 15-pin I/O connector	SR03702894
• Travel Case (metal)	SR03702890
• Protective Bag (canvas)	VSPHD4BAG

Contact Agilent for Rack mounting or specific application requirements.

PHD-4 FEATURES AND BENEFITS



High Sensitivity to Helium – Can detect very small leaks

- High Sensitivity (2 ppm) to helium, three orders of magnitude better than industry standard, due to SIPD (proprietary and patented Selective Ion Pump Detection)
- Excellent selectivity for helium allows you to read helium leaks and ignore all other gases
- Helium sensitivity can be adjusted as required to minimize test costs and helium consumption
- Autozero function allows leak detection even in high helium background environment

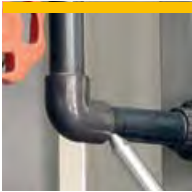

Easy to Use – No training required

- State-of-the-art microprocessor control allows great simplicity of operation
- Fully automatic start-up
- Ready for test in less than 3 minutes
- Intuitive touch screen display
- Visual and audio indicators (standard headphone connection)
- No tuning required



Truly Portable – Compact and light

- The PHD-4 weighs only 2.6 kg (5.7 lbs) including the battery
- Its compact size allows it to be easily carried anywhere
- Its ergonomic design allows comfortable use for extended periods



Versatile – Suitable for many different applications

- Wide range of uses: replaces or can be used with existing methods such as bubble test or pressure decay
- Able to detect both very small and large leaks
- Can operate either on battery power or connected to an outlet
- Displayed messages can be viewed in several languages (English, French, German, Italian).
- Standard Analog and RS232 Serial output.



Dependable – Long term operation

- Automatic backflow valve prevents helium saturation ensuring fast response times, as well as long life of sensing element.
- CE, CSA/US approved for global standardization.



Large Vessels and Bioreactors

The PHD-4 offers unmatched accuracy and repeatability, presenting a unique solution that is cost effective and very well suited for the leak range specifications of this application. Biotech and pharmaceutical industries used to rely on pressure decay and bubble test methods for finding leaks in their large bioreactors. The PHD-4 has established a new standard of quality, significantly increasing production yields.

- Fermenters
- Sterilizers
- Freeze Dryers



Underground Pipes and Storage Tanks

The portability and light weight of the PHD-4 plays a major role in this application. Underground pipes and storage tanks (UST) are slightly pressurized with helium which, due to its high mobility, can escape through small leaks and migrate to the surface, where it can be easily detected by the PHD-4.

The accuracy, portability and light weight of this unit greatly simplifies this process, particularly in difficult construction sites or rough terrain.

- Gas distribution lines
- Under and above ground containers and storage tanks
- Telecommunication and high voltage underground cables



Courtesy of Fraunhofer UMSICHT, Germany

Water Heating and Cooling Pipes

The PHD-4 allows leak location without interruption of the normal operation, by mixing helium with the water in the circuit. Until recently, the precise and rapid location of leaks in buried pipes has been very difficult.

In the event of a leak, helium desorbs from the fluid and diffuses to the surface, where it is easily detected. Leaks in pipeline systems such as district heating systems, drinking or chilled water systems and steam pipe networks incur high costs due to losses and corrosion damage.

- Heater exchangers and steam condensation lines
- Water pipes
- Radiant heating systems



Airplane Fuel Tanks and Lines

PHD-4 technology is approved worldwide by airplane manufacturers and operators as the standard for the location of leaks in aircraft fuel tanks and in oxygen distribution lines.

Agilent works with an exclusive distributor for aircraft applications. Please contact your local Agilent office for more information.

- Fuel tanks
- Oxygen distribution lines

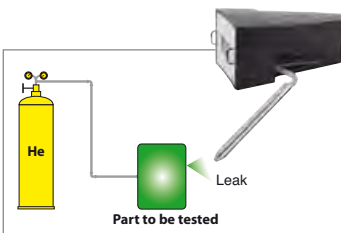

Other Applications

The PHD-4 is in daily use in many other applications. Its portability makes it ideal for factory and field maintenance. Here is a partial list of other applications:

- Components and systems for the Chemical and Petrochemical Industries
- Compressed air components and delivery systems
- Process gas delivery lines in Semiconductor fabrication industry

AGILENT PUMPS DESIGNED FOR LEAK DETECTION

Agilent has the advantage of being a designer and manufacturer of both vacuum pumps and leak detectors. This gives us the proper insight for designing pumps that are perfectly suited for use in leak detection applications.

DS Series Rotary Vane Pumps

Leak detectors require pumps with the ability to quickly pump out the test piece while efficiently pumping and expelling helium from the system. Failure to do so limits leak detector performance. DS series pumps fulfill all the rigorous requirements of use in leak detection while delivering quiet, cool-running and dependable performance. DS Series Pumps:

- provide excellent helium pumping characteristics for stable leak rate signals
- employ forced oil-feed to remain cool even when pumping large volumes
- feature an anti-suck back valve to prevent migration of pump oil toward the leak detector

For technical information on rotary vane pumps, refer to Agilent's Dual Stage Rotary Vane Pump catalog.

Rotary Vane Pump – Outline Drawing

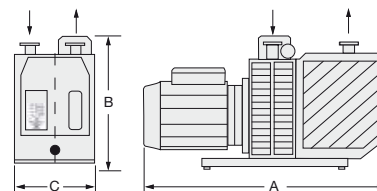

Pump	Pump Speed	A (length)	B (height)	C (width)
DS 42	60 Hz 1.2 cfm	309 (12.0)	192 (7.5)	108 (4.2)
	50 Hz 1.8 m ³ /hr			
DS 302	60 Hz 8.2 cfm	467 (18.4)	212 (8.3)	132 (5.2)
	50 Hz 11.6 m ³ /hr			

TriScroll and IDP Series Dry Scroll Pumps

For many applications, "dry" pumping is essential. In the past, dry pumps have had either low pumping speeds, poor base pressure, or both. Agilent's TriScroll series pumps have revolutionized dry leak detection. With special design considerations implemented specifically for helium mass spectrometer leak detection, our dry pumps conform to rigorous standards without the potential for contamination.

TriScroll pumps:

- provide high speeds for fast evacuation and cycle time
- deliver low base pressure for high sensitivity testing
- use no oil, avoiding contamination and oil disposal
- are optimized for helium pumping

For technical information on scroll pumps, refer to Agilent's Dry Scroll Pump catalog.

TriScroll Pump – Outline Drawing

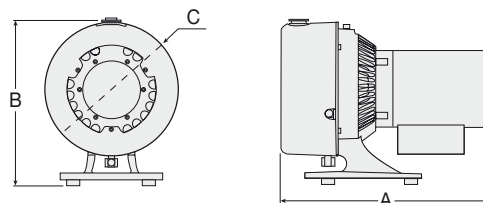

Pump	Pump Speed	A (length)	B (height)	C (width)
TriScroll 620	60 Hz 17.7 cfm	471 (18.54)	355 (13.98)	300 (11.8)
	50 Hz 25.2 m ³ /hr			

MacroTorr Turbo and Turbo/drag pumps

The high vacuum pump in a mass spectrometer system is critical to a well-designed leak detector. These pumps need to deliver high pumping speed to keep the spectrometer tube at low pressure, while offering the correct helium compression ratios to allow for high sensitivity. In addition to offering all of the appropriate pumping characteristics, Agilent's patented MacroTorr turbo and turbo/drag pumps require no periodic maintenance.

- MacroTorr design provides high inlet pressure tolerance
- optimized helium compression ratio permits optimal helium detection and fast signal clean-up
- permanently lubricated bearings need no maintenance

For technical information on turbo pumps, refer to Agilent's Turbo Pump catalog.



Leak Detection Handbook*

The 135-page handbook, *Introduction to Helium Mass Spectrometer Leak Detection*, is useful for experts and novices. It covers leak detection fundamentals, helium leak detector types, equipment calibration, and product fixture design. A wide variety of process-specific application solution notes is also available.

* Available for download



Calibrated Helium Leaks

Agilent offers helium leaks traceable to NIST standards for use in calibrating your leak detector. An NW25 or 1/8" OD tube fitting and isolation valve are provided as standard on the external leaks. The 10⁻⁶/10⁻⁵ range reference helium leak includes a pressure gauge and refill port for evacuation and sniff test calibration.

External

NW25	1/8" Compression Port	
F8473325	F8473320	10 ⁻⁶ /10 ⁻⁵ std cc/sec range refillable sniffing/evacuation leak with pressure gauge and KF25 adapter
F8473321	F8473301	10 ⁻⁷ std cc/sec range, with valve
F8473322	F8473302	10 ⁻⁸ std cc/sec range, with valve
F8473323	F8473303	10 ⁻⁹ std cc/sec range, with valve
F8473324	F8473304	10 ⁻¹⁰ std cc/sec range, with valve

Internal, 1/8" NPT Fitting (without valve)

K3264301	10 ⁻⁷ std cc/sec range
K3264302	10 ⁻⁸ std cc/sec range

Calibration

Calibration of existing leaks is done on an advance exchange basis. To order the recalibration service, simply add "GG" in front of the above part numbers.

Helium Lecture Bottle Kit

L8856301

The Helium Lecture bottle provides a convenient supply of helium for leak testing. Measuring only 14" long and 2 1/2" diameter, the bottle will provide enough helium for a full eight hours of leak testing at normal flow rates. The kit includes a Helium Lecture bottle containing 2 cubic feet of helium at 1800 psi, a pressure and flow regulator (P/N 642972175), and a helium spray probe kit (P/N K0167301) in one package.



Helium Spray Probe Kit

K0167301

For use in spraying helium to find the exact location of a leak. Three nozzles are included: a hypodermic nozzle for pinpointing leaks, a flexible tubing nozzle for hard-to-reach areas, and a long, soft copper nozzle that can be bent into almost any configuration to reach into deep crevices. An easy operating spring handle and 10 feet of hose with a female fitting simplifies attachment to the helium regulator.



Leak Detection Service Contracts

Agilent offers a full range of preventive maintenance and comprehensive on-site support options for all of our leak detectors. See page 28.

Leak Test Data Wizard

VSLTDW

The Leak Test Data Wizard is a comprehensive data management software package for use with our VS Series leak detectors. It is a flexible PC based, graphic-rich tool that makes full use of the data from the VS leak detector to customize automation of basic leak test processes, assuring testing uniformity over time or between operators.



See page 9.

ACCESSORIES AND OPTIONS

Training Programs

Training courses for leak detector operation and maintenance are offered in regularly scheduled classes at our Palo Alto, California or Lexington, Massachusetts facilities. On-site training can also be provided at your plant. Contact your local sales engineer or see the training and service sections of this catalog.

See worldwide service and support on page 28.

See Leak Detector Training Programs on pages 28 and 29.

PHD-4 Bag

VSPHD4BAG

Protective bag for PHD-4 portable sniffer leak detector.



Power Probe

K9565301	Power Probe with 1/8" Test Port Adapter, 10' length
K9565302	Power Probe with 1/8" Test Port Adapter, 25' length
K9565306	Power Probe with KF25 Flange, 10' length
K9565307	Power Probe with KF25 Flange, 25' length
K9565303	Spare Tip Filters (10 each)

The Power Probe is a "sniffer" probe designed to locate leaks emanating from sealed containers internally pressurized with helium. The Power Probe adjusts for varying sensitivity and response time. It is extremely rugged and can be easily disassembled for cleaning.

The probe kit includes 5 tip filters and is available with 10 or 25 feet of connecting tubing and an inlet adapter to fit on the leak detector. It is ideal for fast response with MacroTorr pumped leak detectors.



sniffing

Spectrometer Tube Cleaning Kit

670029096

Kit with pre-saturated wipes and swabs
This Cleaning Kit contains clean wipes pre-saturated with Dow-Corning OS-20 solvent plus cotton swabs for cleaning in small holes or corners. The kit is adequate for three spectrometer cleanings and can also be used for a variety of other vacuum applications.



Test Port Adapters and Kits

L8741301	1/8" Test Port to NW25 nipple adapter
L8741302	1/8" Test Port to NW40 nipple adapter
KCP401125	Adapter from NW40 to 1/8" compression fitting
LDCOMPINADKIT	Test Port Adapter Kit, to 1/8" compression fitting
LDNW25INADKIT	Test Port Adapter Kit, to NW25 fitting

Throttle Valve, for 1/8" Compression Port

626603345

The Agilent throttle valve is a manually operated, NW25 to 1/8" tubulated variable conductance device used to control the flow of gas to the leak detector. It is frequently used in leak detector applications in which a grossly leaking part or vacuum chamber will not permit the leak detector to go into the test mode. The throttle valve is a non-quantitative approach to locating very large leaks in your vacuum system.



Tuning Leak, for 1/8" Compression Port

K1608301

The Tuning Leak consists of a ten-segment calibrated needle valve which can be used as an aid to gross leak testing or for gross leak calibration. The Tuning Leak can be used with any Agilent Leak Detector and can also provide an indication of background helium in the testing area.



Throttle/Tuning Leak Valve with NW25 Fitting

R1947301

For leak detectors with an NW25 inlet, the tuning leak and throttle valves have been combined into one product. This valve performs the same functions as the two described above.



LEAK DETECTION

Universal Test Fixture Option (Flapper Box)

L6241301	947/948 Series, 1½" Compression Port
L6241305	VS/979 Series, 1½" Compression Port
L6241306	VS/979 Series, NW25

This leak detector option makes leak testing of small parts almost totally automatic and very fast. With this option, the total time to test a typical integrated circuit or other small device is less than six seconds. The fixture is clamshell-shaped with tapered walls and a spring-loaded lid. The fixture can be used with the Automatic Sequencer feature in Models 947/948/960 or 979 in order to fully automate and quicken the test cycle. Size: 4" ID x 1" deep. An insert is supplied to reduce the size to 3.25" ID, tapered to 2.83" x ¾" deep.



Probe with 10 m (30') Sampling Line, PHD-4 9693525

For applications in which the length of the standard probe is not adequate, a probe extension is available. It has a maximum length of 10 m, but may be cut to shorter lengths.

Telescoping Extension Probe, PHD-4 9693520

This probe assists the operator when additional rigid length is required, as when checking underground objects, or objects beyond arms length. The tip has a small funnel to better convey helium to the probe.



Probe Set, PHD-4

9693515

This set consists of three different probe tips that can replace the standard tip for specific applications. One tip has a smaller diameter for more precise leak location. A second is more flexible, for easy access to difficult areas, and a third is for general use.



ACCESSORIES AND SPARE PARTS

Ordering Information

Description	Part Number	VS	979	959
Calibrated Leaks				
External calibrated helium leak, 1/8" comp., 10 ⁻⁷ atm cc/sec	F8473301	•	•	•
External calibrated helium leak, 1/8" comp., 10 ⁻⁸ atm cc/sec	F8473302	•	•	•
External calibrated helium leak, 1/8" comp., 10 ⁻⁹ atm cc/sec	F8473303	•	•	•
External calibrated helium leak, 1/8" comp., 10 ⁻¹⁰ atm cc/sec	F8473304	•	•	
External calibrated helium refillable leak, 1/8" comp., 10 ⁻⁶ /10 ⁻⁵ std cc/sec	F8473320	•	•	•
External calibrated helium leak, NW25, 10 ⁻⁷ atm cc/sec	F8473321	•	•	•
External calibrated helium leak, NW25, 10 ⁻⁸ atm cc/sec	F8473322	•	•	•
External calibrated helium leak, NW25, 10 ⁻⁹ atm cc/sec	F8473323	•	•	•
External calibrated helium leak, NW25, 10 ⁻¹⁰ atm cc/sec	F8473324	•	•	
External calibrated helium refillable leak, NW25, 10 ⁻⁶ /10 ⁻⁵ atm cc/sec	F8473325	•	•	•
Internal calibrated leak, 10 ⁻⁷ atm cc/sec range	K3264301		•	
Internal calibrated leak, 10 ⁻⁸ atm cc/sec range	K3264302		•	
Ion Sources				
Ion source, tungsten (new)	82850301		•	•
Ion source, thoriated iridium (new)	82850302		•	•
Miscellaneous				
Spectrometer tube cleaning kit	670029096	•	•	•
Elite Z Rotary Vane Pump oil, 1L	695409005	•	•	•
Helium lecture bottle with regulator and spray probe kit	L8856301	•	•	•
O-Ring Kits				
O-Ring kit for 959 DP	L6749301			•
O-Ring kit for 959 Turbo	L6930301			•
O-Ring kit for 979	R0491301		•	
Preamplifiers				
Preamplifier assembly, 959 (Turbo)	K3333301			•
Preamplifier assembly, 979 standard sensitivity and 959 (MacroTorr)	L9030301		•	•
Preamplifier assembly, 979 high sensitivity	R1003301		•	
Probes				
Power probe sniff accessory, 1/8" fitting, 10'	K9565301	•	•	•
Power probe sniff accessory, 1/8" fitting, 25'	K9565302	•	•	•
Power probe sniff accessory, NW25 fitting, 10'	K9565306	•	•	•
Power probe sniff accessory, NW25 fitting, 25'	K9565307	•	•	•
Tip filters for power probe sniffer (10 each)	K9565303	•	•	•
Helium spray probe (order regulator separately)	K0167301	•	•	•
Test Port Kits				
Test port conversion kit, 1/8" test port to NW25	L8741301		•	•
Test port conversion kit, 1/8" test port to NW40	L8741302		•	•
Test port adapter kit, 1/8" compression fitting	LDCOMPINADKIT		•	•
Test port adapter kit, NW25 fitting	LDNW25INADKIT		•	•
Throttle Valves and Tuning Leaks				
Throttle valve, 1/8" compression Port	626603345	•	•	•
Tuning Leak, 1/8" compression Port	K1608301	•	•	•
Throttle/Tuning Leak Valve, NW25 Fitting	R1947301	•	•	•

LEAK DETECTION

Ordering Information

Description	Part Number
VS Series Accessories and Replacement Parts (Field Replaceable)	
Tip Seal kit, IPD-3 Dry Scroll Pump	IDP3TS
Oil mist eliminator for internal DS 42	VSFLDME
Internal calibrated Leak	VSFLDCL
1½" compression test port	VSFLDCP
Maintenance kit, Diaphragm Pump	VSFLDDP
Filament kit	VSFLDHFR
Hot Ion Source (including filament)	VSFLDHIS
O-Ring kit for VS Series	VSFLDOV
PHD-4 Accessories	
Probe set	9693515
Telescoping extension probe	9693520
Probe with 10 m (30') sampling line	9693525
Capillary leak with refillable reservoir	9693540

*Support of older leak detector models may be limited by availability of component parts and spares.
Please contact our technical support staff for further information.
Ask about opportunities to upgrade to a new, state-of-the-art VS Leak Detector.*

AGILENT GLOBAL SUPPORT NETWORK

Our Customer Service mandate is to provide you with the level of support necessary to increase your productivity, maximize your system uptime, and achieve the highest possible return on your investment.

Application Consulting

Your initial introduction to the Agilent Global Support Network begins when our field engineers assist you in evaluating your requirements to determine the leak detection solution best suited to your application.



Application Consulting

Trade-Up Program

Offers trade-in opportunities of your older units toward the purchase of a new VS Leak Detector – maximizes return on investment.



Trade Up Program

Field & Factory Support

In order to maximize your system uptime and extend the value of your investment, we offer a complete range of support programs that meet all your needs.



Field & Factory Support

AGILENT ADVANTAGE

Agilent Service Guarantee

Agilent Service Guarantee

Agilent's service guarantee means that if we can't fix it, we'll replace it. No other company offers this level of commitment to keeping you up and running at peak efficiency.



LEAK DETECTION

Onsite Integration Support

When its time to install your new equipment, your local engineer will provide hands-on integration and training assistance.



Onsite Integration Support



Ongoing Technical Support

Ongoing Technical Support

When you are a member of the Agilent Global Support Network, support is for the life of your instrument. We provide toll-free technical support, application analysis and rapid problem resolution.

MAXIMIZING YOUR
PRODUCTIVITY AND
SYSTEM UPTIME

Leak Detection Technology and Methods Training



Leak Detection Technology and Methods Training

Comprehensive classes in Leak Rate Test & Measurement and Leak Detector Maintenance provide in-depth and hands-on instruction to allow you to get optimal use of your equipment.

Agilent Certified Parts



Agilent Certified Parts

Repairs and maintenance are performed by factory-trained field engineers using Agilent certified parts. This protects the quality, reliability, and performance of your leak detector.

Learn more: www.agilent.com/chem/leakdetection

TRAINING

Leak Rate Test & Measurement



Course Description

Leak Rate Test and Measurement provides a comprehensive introduction to production testing of parts against leak-rate specifications, and measuring and locating leaks in pressurized systems/components, using popular Helium Mass Spectrometer Leak Detectors (HMSLDs) and various application test fixtures.

The 2-Day Stand-Alone course presents principles of operation of the spectrometer and underlying vacuum fundamentals in a classroom setting. Operation, tuning, and calibration of the leak detector are covered in practical demonstration/laboratory sessions. Leak testing methods designed to solve various problems are discussed and demonstrated.

The 1-Day Companion course builds on the vacuum and Helium Mass Spectrometer Leak Detector (HMSLD) fundamentals learned in BVP, and provides an introduction to production testing of parts against leak-rate specifications, and measuring and locating leaks in pressurized systems/components, using an HMSLD. Leak testing methods designed to solve various problems are discussed and demonstrated.

Who Should Attend?

Engineers and operators who are responsible for quality control of production parts and assemblies. Also, technicians responsible for the maintenance of pressurized and evacuated systems such as those found in power generation facilities, process gas delivery, and refrigeration, etc

Course Goals and Objectives

After completing this course, participants will be able to:

- Identify advantages and disadvantages of various leak testing methods
- Describe rate-leak specifications and helium conversions.
- Select, setup, and perform the proper leak test technique for a given application

Students who take the 2-Day Stand-alone course will be able to:

- Explain vacuum fundamentals and concepts essential to the operation of an HMSLD
- Describe principles of operation of a mass spectrometer
- Properly operate, tune, and calibrate an HMSLD

Course Outline

Stand Alone (LRTM-SA)

2 Days

Basic Vacuum Practice is the required prerequisite and scheduled to immediately precede LRTM-BC.

Day 1

- Introduction to Leak Detection
- Vacuum Fundamentals for Leak Detection
- Introduction to Rough Vacuum Systems
- Introduction to High Vacuum Systems
- Helium Leak Detector Fundamentals
- *Demo LAB:* Tuning, zeroing, and calibration

Day 2

- HMSLD performance considerations
- Leak-Rate Specification Conversions
- Locating Leaks
- Measuring Leak Rate
- *Demo LAB:* Measure leak rates
- Application-Specific Leak-Rate Testing examples
 - Hermetically sealed parts
 - Pressurized parts: accumulation method
 - Pre-pressurized parts in large vacuum chamber
 - Parts with pressure-differential intolerance
 - Small part/high sensitivity
 - Long narrow tubes
 - Process gas
 - Components and systems

Course Outline - BVP-Companion (LRTM-BC)

1 Day

Basic Vacuum Practice is the required prerequisite and scheduled to immediately precede LRTM-BC.

- Introduction to Leak Detection
- Leak-Rate Specification Conversions
- Locating Leaks
 - *Demo LAB:* Find leaks in evacuated & pressurized parts
- Measuring Leak Rate
 - *Demo LAB:* – Measure leak rates
- Application-Specific Leak-Rate Testing examples
 - Hermetically sealed parts
 - Pressurized parts: accumulation method (joints/welds/ crimps, AC lines, brake lines, valves)
 - Pre-pressurized parts in large vacuum chamber (compressor, heater core, wheel, gas tank, transmission, torque converter)
 - Parts with pressure-differential intolerance (gas tanks, gas caps, filler necks)
 - Small part/high sensitivity
 - Long narrow tubes
 - Process gas components and systems

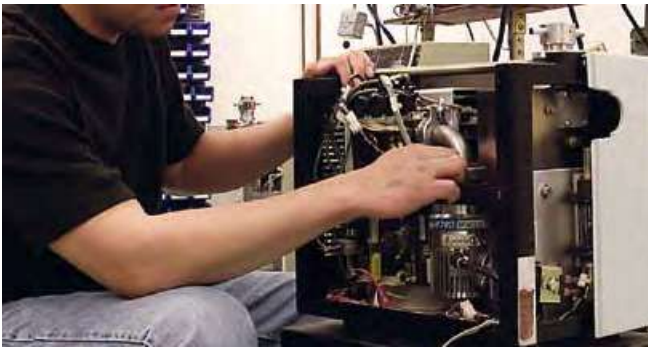

Course Description

This course provides participants with the ability to perform routine maintenance and troubleshooting procedures on supported Agilent Leak Detectors. Scheduled training is available for the following Agilent models: 959, 979, and VS. Training for other Agilent LD models is available through our On-Site Training program. This course begins with an introduction to leak detection and vacuum fundamentals then moves on to cover the principles of operation of the spectrometer and the underlying vacuum system in a classroom setting. Operation, tuning, and calibration of the leak detector, as well as preventative maintenance and troubleshooting procedures, are covered in practical laboratory sessions.

Lab equipment, including Agilent leak detectors and various maintenance consumables, is provided for extensive hands-on lab activities and instructor-led demonstrations. Participants will work with the Agilent leak detector model that they use in their work environment.

Who Should Attend?

This course is for maintenance technicians and personnel responsible for maintaining Agilent leak detectors.

Course Goals and Objectives

After completing this course, participants will be able to:

- Explain vacuum fundamentals and concepts essential to the operation of a leak detector
- Describe principles of operation of a helium mass spectrometer and ContraFlow
- Identify all major LD components
- Properly operate, tune, and calibrate the LD
- Perform preventative maintenance procedures:
 - Spectrometer cleaning and seal replacement
 - Ion Source replacement
 - Valve blocks and manifold cleaning
 - Mechanical and high vacuum pumps
 - Troubleshoot routine problems

Course Outline

Day 1

- Introduction to Leak Detection
- Overview of Vacuum for Leak Detectors
- Introduction to Rough Vacuum Systems
 - *Hands-On LAB*: Roughing pump-down
- Introduction to High Vacuum Systems
- Leak Detector Fundamentals
 - *Hands-On LAB*: ID system components

Day 2

- Operation of the Leak Detector
- Spectrometer Tuning, Zeroing, and Calibration
- Spectrometer Maintenance Procedures
 - *Hands-On LAB*: Clean spectrometer and replace Ion source
- System Electronics
 - *Hands-On LAB*: ID components and verify test point data
- Gauge Maintenance
 - *Hands-On LAB*: Calibrate test port and system gauge

Day 3

- Valve Block and Manifold Maintenance
 - *Hands-On LAB*: Clean valve block and manifold
- Mechanical Pump Maintenance
 - *Hands-On LAB*: RV/TS pump maintenance
- High Vacuum Pump Maintenance Procedures
 - *Hands-On LAB*: DP/TP pump maintenance
- System Troubleshooting
 - *Hands-On LAB*: Troubleshoot common problems

ADVANTAGES OF HELIUM LEAK DETECTION

Why Helium Leak Detection?

Helium is a superior choice of tracer gas used to find leaks for a multitude of reasons. Helium is:

- Non-toxic
- Inert and non-condensable
- Normally not present in the atmosphere at more than trace amounts
- Relatively inexpensive
- Readily passes through leaks due to its small atomic size
- Non-flammable
- Available in various size cylinders
- Available in purities appropriate for medical usage

The only molecule smaller than helium (mass 4) is hydrogen (mass 2), which is not inert. Helium is much lighter than the next heavier inert molecule, neon (mass 20) which is much more expensive. Helium is present at a concentration of only 5 ppm in normal atmospheric conditions.

Other Leak Test Methods Often Fall Short

There are many other methods of leak testing but none that can match the ability of helium leak testing to locate and quantify leaks (Figure 1).

Acoustic Leak Detection uses sonic or ultrasonic energy that is generated by a gas as it expands through an orifice. This method is fairly simple and fast but is only sensitive to 10^{-3} atm cc/second.

Bubble Testing is a common method of leak detection in industry today. It can be as simple as pressurizing a part, placing it under water, and looking for leaks. It can also be done by pressurizing the part with air, applying a soapy solution, and looking for bubbles. This method is simple and cost effective for locating large leaks but also has its drawbacks. The test piece gets wet and may therefore need drying. It also cannot measure total leakage rates and is only useful for 10^{-4} atm cc/second leaks and larger.

Pressure Decay is commonly used in plumbing and many other industries. It may only involve a compressor and a pressure gauge, though some systems can be much more complex and expensive. The sensitivity of this method is proportional to time but generally limited to 10^{-4} atm cc/second. Another problem with this method is that fluctuations in temperature degrade the accuracy of the tests.

Halogen Gas Detection is commonly used in the air conditioning and cooling industry. This technology uses an infrared type detector to detect the presence of halogen tracer gas. This requires the test piece to be charged with Halogen, which is impractical, expensive, and can be an environmental issue.

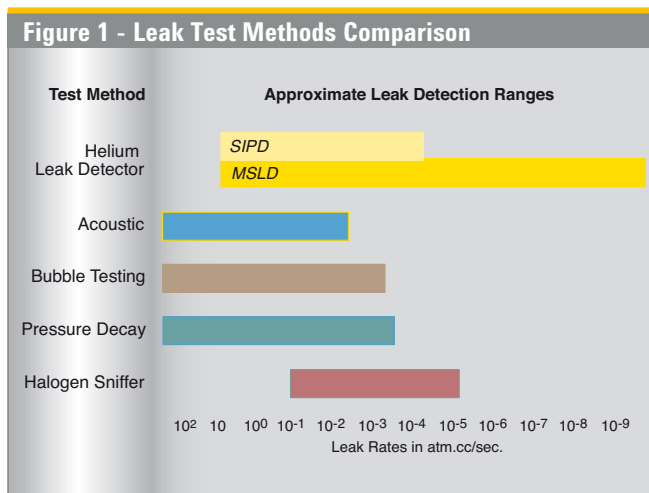

LEAK DETECTION

Agilent's Helium Leak Detection Technologies

A Mass Spectrometer Leak Detector (**MSLD**) is a complete system for locating and/or measuring the size of leaks into or out of a device or a container. This method of leak detection is initiated when a tracer gas, helium, is introduced to a test part that is connected to the MSLD system. The helium leaking from the test part diffuses through the system, its partial pressure is measured, and results are displayed.

The MSLD operating principle consists of ionization of the gases in a vacuum and their acceleration across a voltage drop and a magnetic field (Figure 2). The helium ions are separated and collected, and the resulting ion current is amplified and indicated on the display.

A mass spectrometer leak detector consists of the following components:

- A spectrometer tuned to detect helium
- A vacuum system to maintain adequately low pressure in the spectrometer
- Primary pumps to evacuate the part to be tested
- Valves that enable the various stages of the leak detection cycle, from evacuation, to test, to venting
- Amplifier and readout instrumentation that monitors spectrometer output signal
- Electrical power supplies and controls that sequence valve's, protective circuits, etc.
- Fixturing that attaches the part to be leak-tested to the leak testing equipment

Figure 2 - Mass Spectrometer Tube Schematic

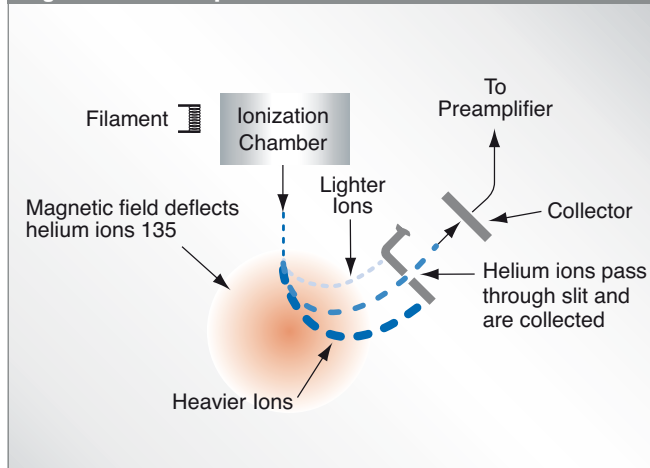

The PHD-4 Portable Helium Detector is also sensitive to helium and is based on a patented technology called Selective Ion Pump Detection (**SIPD**) (Figure 3). The sensor technology incorporates an ion pump connected to a quartz capillary tube and maintained under high vacuum. This membrane is heated with a coiled platinum filament. Once heated, the membrane becomes permeable to helium. As the partial pressure of helium in the ion pump increases, so does the current draw of the ion pump. This current is proportional to the pressure and is therefore representative of the helium at the test probe of the PHD-4.

A selective ion pump detector consists of the following:

- An ion pump and controller
- A permeable quartz capillary
- A heater coil that surrounds the quartz capillary
- Electronics to process the signal
- Display for access to leak rate and other unit functions

Figure 3 - Selective Ion Pump Detector

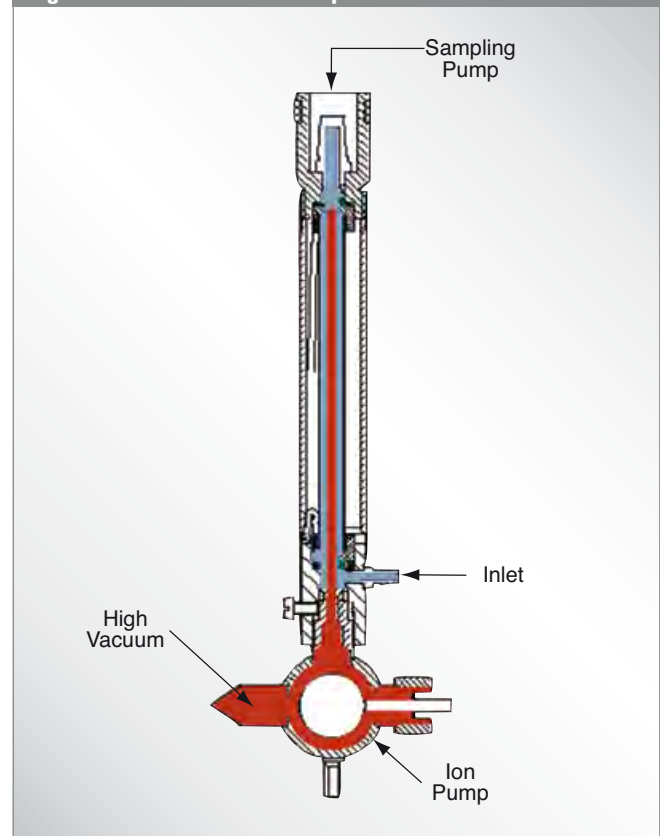

LEAK DETECTION METHODS

Methods of Leak Testing

There are many different ways to leak test parts using helium as a tracer gas. In general, the leak detection method is selected based on the actual working conditions of the part being tested. It is recommended that during leak testing, the same pressure differential be maintained and in the same “direction” as exists during the actual use of the part. For example, a vacuum system is tested with a vacuum inside the chamber, while a compressed air cylinder should be tested with a high pressure inside the cylinder.

There are also two general concerns when leak testing. One is the location of leaks and the other is the measurement of the total leakage rate of the part, as some leakage may be acceptable. In many cases, parts may be first tested to determine if they pass an acceptable level, and if not, the part may be taken off line and subjected to a second test with the intent of locating the leak. Additionally, many parts may be tested in batches. If a batch fails, the individual parts in that batch may then be tested separately to identify the leaking part(s).

Vacuum Testing Method (Outside-in)

The part to be tested is evacuated with a separate pumping system for large volumes, or with just the leak detector itself. When the appropriate cross over pressure has been reached, the leak detector is valved-in or transfers into test and the part is tested using one of the following methods:

Locating Leaks (Figure 1)

To pinpoint the location of the leak(s) (but not measure the total leakage rate), helium is administered to the suspected leak sites of the part using a spray probe with an adjustable flow.

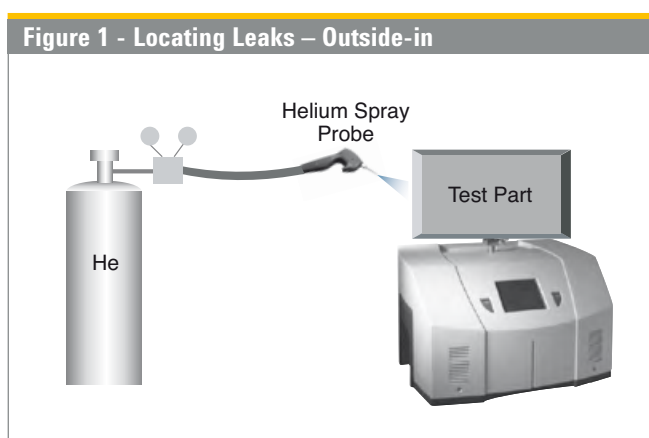

Measuring Leaks (Figure 2)

To determine the total quantity of leakage (but not the number or location of leaks), the part is connected to the leak detector and shrouded by a helium environment. This helium environment can be contained in many methods ranging from a simple plastic bag to more complex bell jar arrangements.

Figure 2 - Measuring Leaks – Outside-In

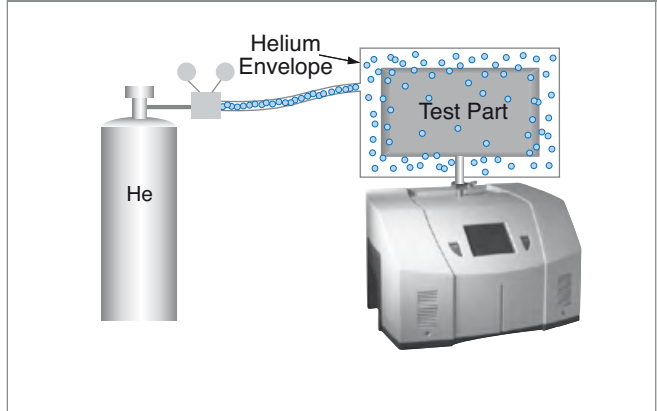

Pressure Testing Method (Inside-out)

In this technique, the part is pressurized with helium or a mixture of helium and air, and tested by one of the following methods:

Measuring Leaks (Figure 3)

To determine the total quantity of leakage (but not the number or location of leaks), the part is pressurized with helium (or a mixture of helium and air or nitrogen). This can be done by bombing or backfilling small hermetically sealed parts. Larger parts can be actively pressurized using a hose or tubing to deliver the helium. The part is placed in a volume that is then evacuated by the leak detector. All the helium escaping from the part is captured and quantified.

Figure 3 - Measuring Leaks Inside-out

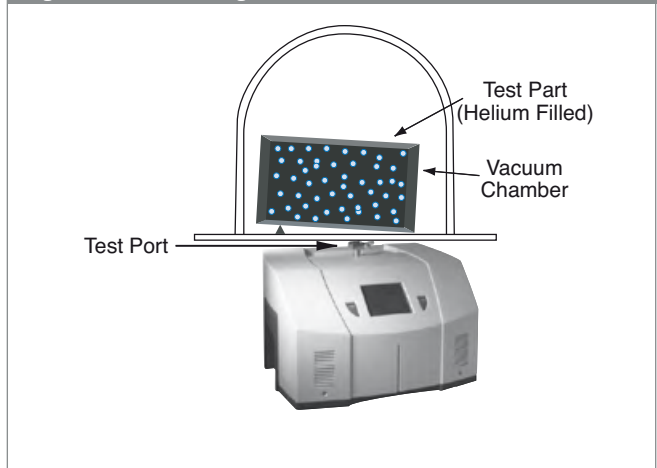

LEAK DETECTION

Locating Leaks (Figure 4)

To pinpoint the location of the leak(s) (but not measure the total leakage), the likely potential leak sites of the part are scanned using a Sniffer Probe connected to the inlet of the leak detector.

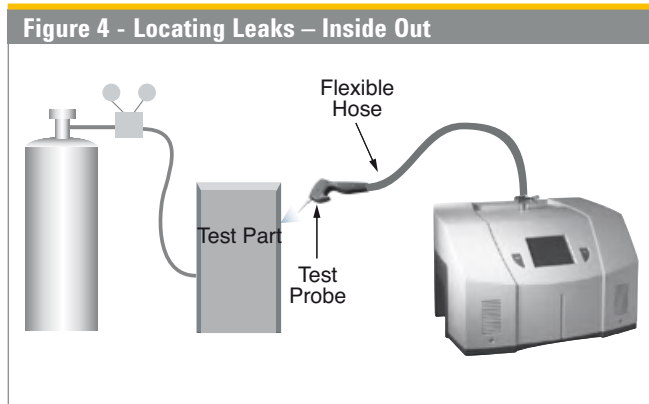

Accumulation Testing Method (Figure 5)

This method can both locate and quantify leaks. Some type of shroud or hood is placed in such a manner as to envelop a potential leak site. A certain amount of time is given to allow leaking helium to accumulate in the shrouded area, increasing the helium concentration. The leak detector is then valved-in to the shrouded volume. If many potential leak sites exist in a manifold or if many parts are to be tested at the same time, they can be sequentially valved-in to determine which site is leaking.

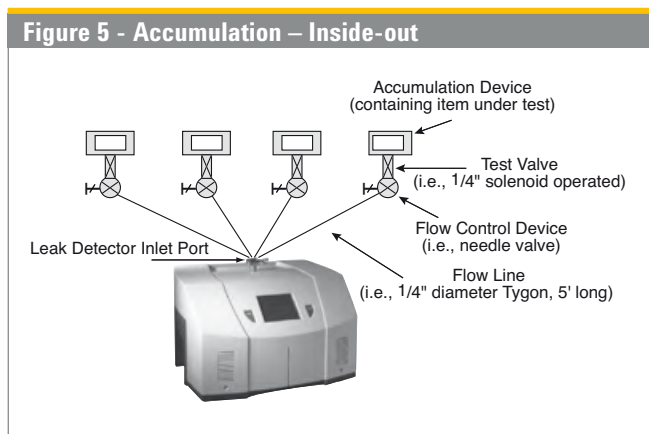

System Leak Test Methods

Systems, like individual parts, should be tested with the same pressure differential and in the same direction as in actual use. Therefore, systems that are under vacuum while in operation should be leak tested under vacuum, while pressurized systems should be charged with helium to a pressure similar to operational conditions when possible.

Vacuum Systems (Figure 6)

In general, vacuum systems are tested with a portable leak detector. Typically the leak detector is connected by means of a "tee" connected in between the foreline of the high vacuum pump and the inlet of its backing pump. A system should be capable of maintaining a foreline pressure low enough to operate the leak detector at this location. Helium is supplied to potential leak site using a spray probe or "bagging" suspected areas. If a leak exists, helium will enter the system and rapidly diffuse through it. The leak detector should respond within several seconds or less. Note that leak detector sensitivity will be diminished in systems with large backing pumps. If a system is using a cryopump as a high vacuum pump, it must be valved off before helium is introduced as cryopumps have limited helium pumping capacity.

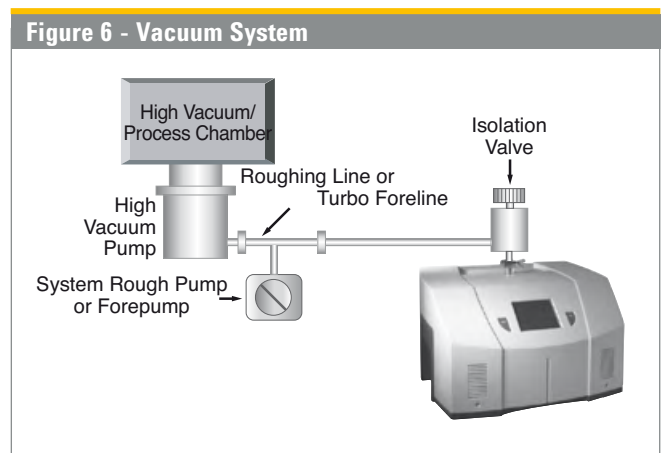

Pressurized systems

Many different types of pressurized systems also need to be leak-free. These systems can be charged with helium or some mixture of helium and another gas such as nitrogen. If a diluted helium mixture is used, the helium signal will be diminished proportionally. For example, if a mixture of 10% helium and 90% nitrogen is used, the signal will read 10% of the actual value of the leak, or a decade lower. This may be acceptable in many cases as system leak checking is usually to locate rather than quantify leaks. Once the system has been charged with an appropriate amount of helium, leak checking can be performed by means of a sniffer probe, or by "bagging" suspected leak sites so that leaking helium will accumulate to a detectable level.

TYPICAL LEAK DETECTION APPLICATIONS



Maintenance of Systems

Many vacuum process tools in fabs of all types require occasional leak checking. This may be part of a preventative maintenance schedule or in the event of an unexpected failure. Downtime in either case must be minimized. A rugged, dependable, fast starting leak detector is essential to maximize up time of production tools. Agilent VS Series, 959, and PHD-4 portable leak detectors keep industry moving. Examples of some of these applications are:

Vacuum process equipment or tools

- Vacuum furnaces
- Vacuum coaters
- Beam lines
- Electron beam and ion beam process equipment
- Analytical Instruments
- Semiconductor process tools
- Laser process equipment

Pressurized systems

- Power Plants
- Underground tanks, cables, and pipes
- High purity gas handling systems
- Bioreactors and fermenters
- Liquid gas manufacturing facilities
- Fuel tanks and bladders

Quality Control of Production Parts and Assemblies

The detection and location of leaks is critical in the production of many products from individual components, to sub-assemblies, to completed systems. In many of these cases, it is as important to know the size or rate of the leak as it is the location. Whether quantitative or qualitative testing is required, our leak detectors help assure the leak integrity of your parts or assemblies. Some examples include:

Evacuated parts and assemblies

- Hermetically sealed electronic packages
- Valves and manifolding
- Feedthroughs/glass-to-metal seals
- Vacuum vessels and systems

Pressurized parts and assemblies

- Air conditioning and refrigeration assemblies
- Radiators, heat exchangers, and condensers
- Brake, fuel, and hydraulic lines
- Gas tanks
- Food storage tanks and packaging
- Body implantable medical devices
- High purity piping

System Integrated Leak Detection

Manufacturers of large, complex systems may choose to integrate into those systems a component leak detector that can facilitate the on-going maintenance of leak-free integrity, thereby providing additional value to their customers. The Agilent VS C15 Component Leak Detector provides the necessary elements for flexible integration of leak detection capability into a large system. Examples of these systems are:

- Semiconductor process equipment
- PVD/CVD equipment
- E-beam and ion beam processing equipment



Small, compact, self-contained footprint inside your system.

Mass Produced Parts

Some manufacturing processes require the integration of a leak checking device into a multi-step process, usually with very high production rates. Component leak detectors are designed specifically for these applications in which a vacuum system and the control electronics may be mounted separately. The Agilent VS C15 offers the ultimate flexibility in a helium mass spectrometer leak detection system. The flexibility, ruggedness and rapid response time of these units allows for accurate, repeatable, high volume leak testing in demanding production environments. Some examples include:

High Volume Manufactured Parts

- Automotive fuel systems
- Automotive brake components
- Cooling and refrigeration system components
- Medical devices
- Automotive airbag components
- Tire and wheel assemblies



Portable Sniffing Applications

Some applications require operators or technicians to look for leaks from a ladder, outdoors, above or below ground, or in a densely constructed industrial facility or power plant. In these cases, a mobile cart-mounted MSLD may not be practical. A truly portable unit such as the PHD-4 is required. Some examples of such applications are:

- Aircraft manufacturing and maintenance
- Power generating plants
- Pressurized pipelines
- Bioreactors and fermenters
- Petrochemical plants and refineries
- Underground tanks
- Large condensers or heat exchangers

APPLICATIONS TABLE - General Guidelines for Leak Detection Methods and Equipment

The chart below is a general guide to assist you in determining which leak detector and test method is the correct solution for your application. This information should be used in conjunction with guidance from your Agilent Sales Engineer.

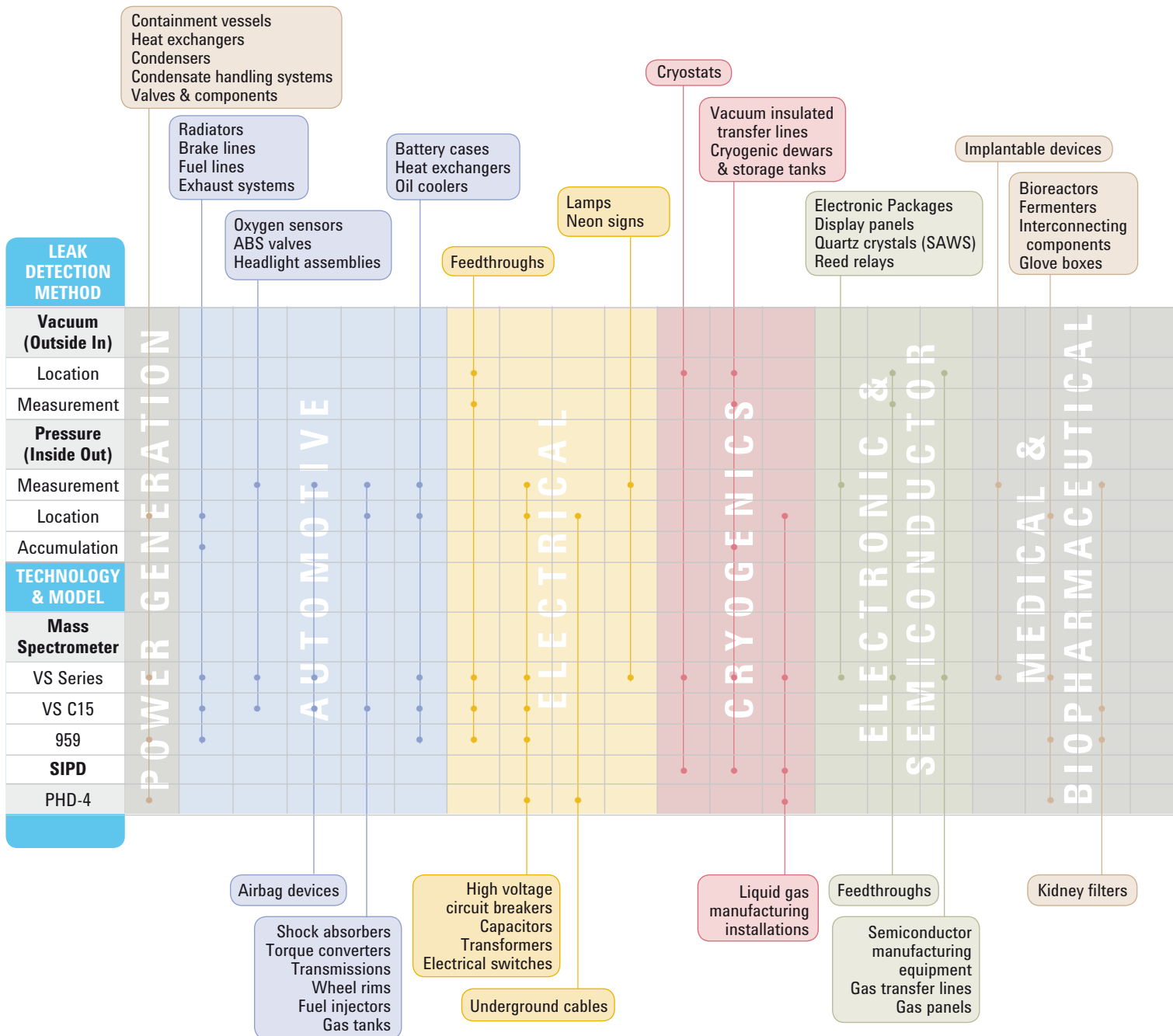

LEAK DETECTION

To determine the appropriate leak detector for your application:

1. Find the colored column of table that relates to your application: Power Generation, Automotive, etc.
2. Find part(s) that are similar to your part to be tested. The parts are shown on the top and bottom of the table.
3. Find dots that indicate the suggested leak check method and equipment.

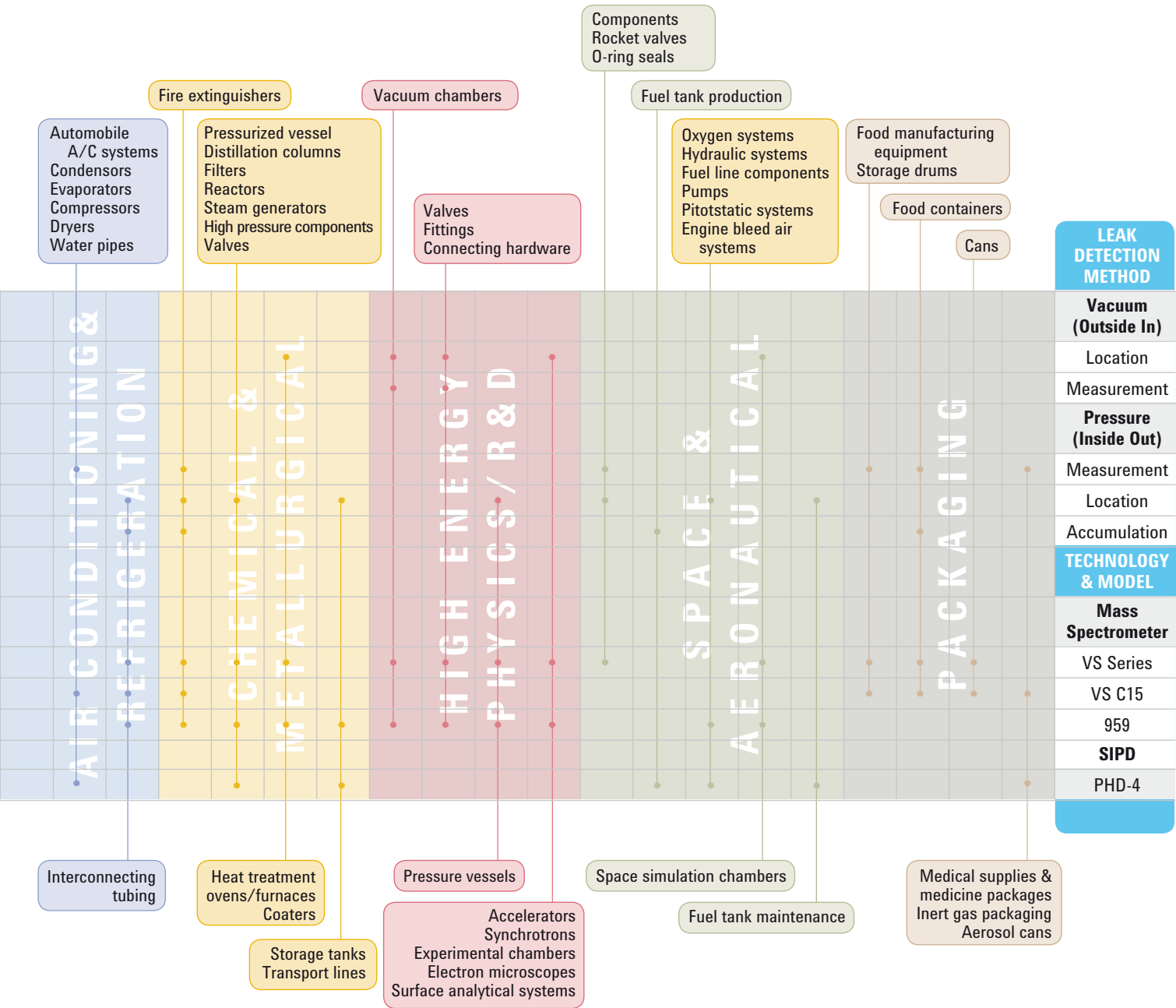

Leak Detection

DESIGN AND APPLICATION CONSIDERATIONS

The Effect of Helium Pumping Speed

Detecting a leak quickly is one of the most important requirements in using a helium leak detector or a leak detection system. This requirement is characterized by the following elements:

- Response time
- Appearance time
- Disappearance (cleanup) time

1. Response time

Response time is defined as the time required for a leak detector to measure 63 % of the peak helium signal. This response time is based on an exponential behavior (Figure 1). This shows the appearance of a 10^{-7} std. cc/sec leak signal.

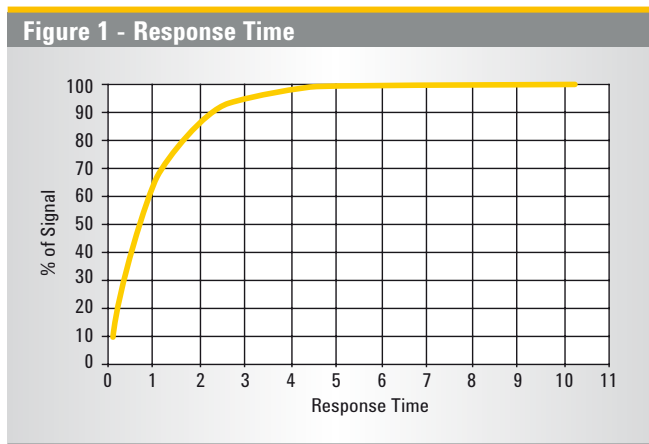

In order to quickly measure the signal in a vacuum application, the response time should be as short as possible. In general, a larger test volume will yield a slower response time. Also, a test volume connected to the detector by a long, narrow tube will negatively affect the response time, since helium must travel through the tube to the detector.

For a given volume, the effective pump speed of the leak detector or leak detection system must always be as large as possible. To optimize cycle time, for example in a production application, auxiliary pumps can be used to obtain the desired objectives. These pumps must be sized and correctly integrated to yield maximum effectiveness.

2. Appearance time

Appearance time is the time required to see an increase of signal, above the background level, after helium is admitted to a leak. Appearance time is only a first indication of a leak and does not indicate the eventual magnitude of the leak rate. This is different from response time, which is calculated from the peak value. The first "appearance" of a leak is often sufficient to stop a test cycle before a test chamber becomes saturated with helium, thus avoiding a lengthy cleanup period. In some applications, it is sufficient to know that there is a leak without knowing the actual magnitude of the leak and

the full response time. The outstanding background subtraction capabilities of Agilent's VS series helium leak detectors is of great importance in improving appearance time.

3. Disappearance time.

Disappearance time (cleanup time) is the time required for a leak detector to recover to a desired sensitivity after exposure to a leak. Here one will observe the most noticeable time difference between a high performance and low performance leak detection system arrangement. A high pumping speed will yield significantly faster cleanup times.

Selecting the Proper Connections

In most situations when using the Outside-in Vacuum Method, it is necessary to install a connection between the leak detector and the part or chamber to be evacuated. Sizing this connection is an important aspect of the leak detection system performance because, 1) the connection adds volume to the total system arrangement, and 2) it restricts the helium pumping capability of the leak detector system.

Selecting an inappropriate connection line can alter the capabilities of a leak detector system. For example, a tube of 4 feet in length by 0.40 inches in diameter has a conductance of 0.27 l/s for helium in molecular flow (Figure 2). This means that even the most powerful helium leak detector will not deliver a pumping speed higher than 0.27 l/s. Using this value in the calculations provided for response time, appearance time, and disappearance time will clearly demonstrate the impact of limited conductance.

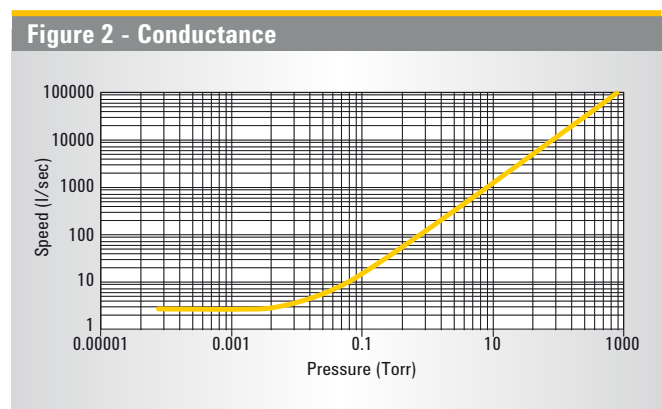

The Evacuation Process

In order to leak test a part by the Outside-in Vacuum Method, it is necessary to evacuate the part or the chamber in which the part is placed. The required vacuum level will depend on the acceptable leak rate requirements. (See section on helium background, page 41.)

LEAK DETECTION

Figure 3 - Evacuation

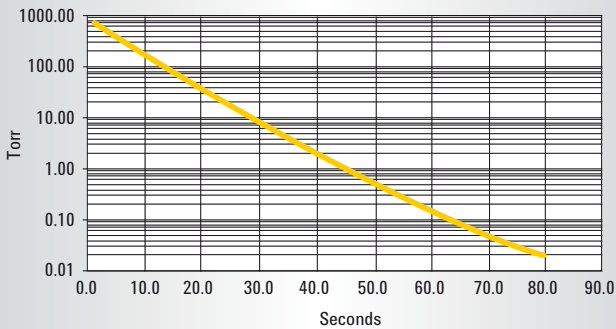

To reach the appropriate level in a timely fashion, it is necessary to select a pumping system based on the right pump characteristics, pumping speed and base pressure, as well as the right manifolds arrangement, conductance limitations and added volume considerations.

When purchasing a self contained helium leak detector that is equipped with its own roughing pump, special attention should be paid to the size of the pump to avoid the need for purchasing auxiliary pumps, manifold, or control equipment.

Appropriate Helium Background Conditions

As shown in Figure 4, helium is present in ambient air at 5 parts per million (ppm). Although this is a very low level when looking for leaks as small as 10^{-9} std. cc/sec, helium background remains an issue.

Figure 4

Gas	Symbol	% by Volume	PPM
Nitrogen	N ₂	78.08	780800
Oxygen	O ₂	20.95	209500
Argon	Ar	0.93	9300
Carbon Dioxide	CO ₂	0.03	300
Neon	Ne	0.0018	1
Helium	He	0.0005	5
Krypton	Kr	0.0001	1
Hydrogen	H ₂	0.00005	0.5
Xenon	Xe	0.0000087	0.087

When testing by the Outside-in Vacuum Method, correct evacuation conditions and proper spraying technique, combined with adequate ventilation, are key to maintaining proper detector system operation. Proper charging, venting and careful release of the helium after a test are critical in testing by the Inside-out Sniffing Method.

Agilent's VS series leak detectors are equipped with unique helium background suppression features that allow compensation of >2 decades of helium background (Floating Zero).

Parallel Operation

If the volume of the part to be tested is very large or the cycle time very short, an auxiliary pumping station may be required operating in parallel with the leak detector (see Figure 5). In this situation, the auxiliary pump or pumping station is used for roughing only.

Figure 5 - Parallel Operation

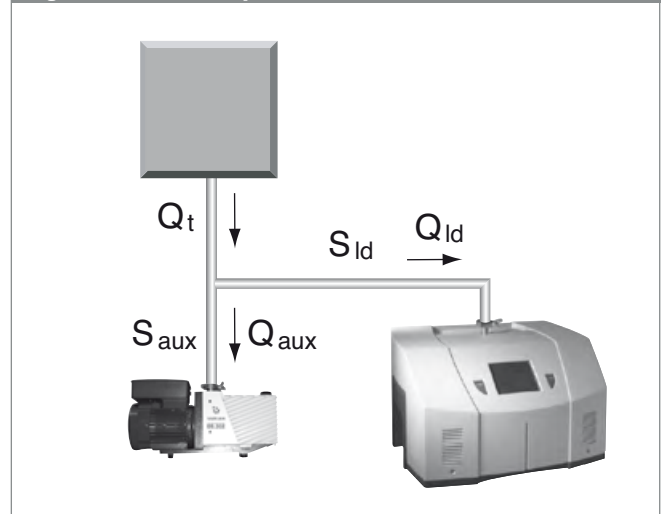

Calculation of response time, appearance time, and disappearance time must be considered in both the effective helium pumping speed provided by the detector and the effective helium pumping speed provided by the auxiliary pump at the chamber. The total helium flow (Q_t) coming through a leak and through the chamber will be split in a flow (Q_{ld}) towards the detector and flow (Q_{aux}) towards the auxiliary pump. This will result in a decrease of the indicated leak rate at the leak detector, for which must be compensation must be made.

Helium Consumption

Based on the attainable sensitivity using the helium leak detection method, parts to be tested may be charged with a helium/gas mixture to reduce the helium consumption. This is especially true for large parts or production type testing. Lower Helium consumption may also be achieved by raising the pressure inside the part to be tested, while lowering the concentration. The effect will vary depending on the flow conditions of the actual leak.

EQUATIONS FOR USE IN HELIUM LEAK DETECTION

Response time in molecular flow: $t_{63} = \frac{V}{S}$

With: t = Time in seconds to 63% of full signal
 V = Volume in liters
 S = Helium pumping speed in l/s

Appearance time in molecular flow: $t_a = \frac{V}{S} \times 2.3 \times \log \frac{Q}{Q-Q_m}$

With: t_a = Appearance time in seconds
 V = Volume in liters
 S = Helium pumping speed of the detector in l/s
 Q = Leak rate in mbar.l/s
 Q_m = Smallest detectable leak in mbar.l/s

Split flow calculations: $(Q_{ld}) = \frac{(S_{ld})}{(S_{ld}) + (S_{aux})} \times (Q_t)$

With: (Q_{ld}) = Helium flow towards the leak detector
 (Q_t) = Total helium flow from the chamber towards the LD + auxiliary pump
 (S_{ld}) = Helium pumping speed of the leak detector
 (S_{aux}) = Helium pumping speed of the auxiliary pump

Disappearance time in molecular flow: $t_d = \frac{V}{S} \times 2.3 \times \log \frac{Q}{Q-Q_m}$

With: t_d = Disappearance time in seconds
 V = Volume in liters
 S = Helium pumping speed of the detector in liters/second
 Q = Leak rate in mbar l/sec
 Q_m = Smallest detectable leak in mbar.l/s

Gas loss under viscous flow conditions: $Q = \frac{R}{M} \times \frac{22400}{365 \times 24 \times 3600} \times \frac{T}{273}$

With: Q = Leak rate in mbar l/s
 R = Gas loss in grams/year
 M = Molecular weight gas
 T = Temperature in degrees Kelvin
 22400 = Volume of one mole of gas at 273 °K and 1 atm in cc
 365 x 24 x 3600 = seconds in one year

Evacuation time: $t = \frac{V}{S} \times 2.3 \times \log \frac{P_1}{P_2}$

With: t = Evacuation time in seconds
 V = Volume in liters
 S = Pumping speed in l/s
 P₁ = Beginning pressure in mbar
 P₂ = Ending pressure in mbar

Gas flow under viscous flow conditions:

$$Q = \frac{3.14 \times D^4}{256 \times \text{visc}} \times L \times (P_1^2 - P_2^2)$$

With: Q = Leak rate in mbar l/sec
 D = Leak diameter in cm
 L = Length of the leak in cm
 visc = viscosity of the gas in bar s
 P₁ = Absolute pressure one side of the wall in bar
 P₂ = Absolute pressure other side of the wall in bar

Gas flow under molecular flow conditions for long cylindrical tube:

$$Q = \frac{1}{6} \times \sqrt{\frac{2 \times 3.14 \times R \times T}{M}} \times \frac{D^3}{L} \times (P_1 - P_2)$$

With: Q = Leak rate in mbar l/sec
 L = Length of the leak in cm
 D = Leak diameter in cm
 M = Molecular weight gas
 R = Gas constant (8.3 E7)
 T = Temperature in degrees Kelvin
 P₁ = Absolute pressure one side of the wall in bar
 P₂ = Absolute pressure other side of the wall in bar

Bombing calculation for hermetically sealed packages

$$R1 = \frac{L \cdot Pe}{Po} \left(1 - e^{-\left[\frac{L}{Po \cdot V} \cdot t1\right]} \right) e^{-\left(\frac{L}{Po \cdot V} \cdot t2\right)}$$

With: L = The leak rate specification in atm cc/sec He
 Pe = The bombing pressure in atmospheres
 Po = Atmospheric pressure (usually 1 ATM)
 t₁ = Bombing time in seconds

V = Internal free volume of the package in cubic centimeters
 t₂ = Dwell time between end of bombing cycle and start of leak test in seconds

Accumulation Method

Calculating helium concentration increase

$$C = \frac{Q \times T \times 1 \times 10^6}{V_{\text{CHAMBER}} - V_{\text{PART}}}$$

With: Q = Leak rate from part in atm cm³/sec
 T = Soak time in seconds

Calculating detection time

$$T = \frac{C(V_{\text{CHAMBER}} - V_{\text{PART}})}{Q \times T \times 1 \times 10^6}$$

V = Volume in cm³
 C = Increase in He concentration in ppm

Pumping Speed

	cfm	l/minute	l/sec	m³/hour
1 cfm	1	28.32	0.472	1.6977
1 l/minute	0.035	1	0.016	0.06
1 l/sec	2.12	60	1	3.6
1 m ³ /hour	0.589	16.67	0.27	1

Flow/Leak Rate

	atm cc/sec	mbar l/sec	Torr l/sec	Pa m³/sec	sccm
1 atm cc/sec	1	1	0.76	0.1	60
1 mbar l/sec	1	1	0.76	0.1	60
1 Torr l/sec	1.3	1.3	1	0.13	80
1 Pa m ³ /sec	10	10	7.5	1	600
1 sccm	0.016	0.016	0.0125	0.0016	1

Pressure

	Torr	mbar	Pa	micron	psi	atm
1 Torr	1	1.33	133	1000	0.0193	0.00132
1 mbar	0.751	1	100	750	0.014	0.0009
1 Pa	0.00751	0.01	1	7.5	0.00014	0.000009
1 micron (mTorr)	0.001	0.0013	0.13	1	0.000019	0.0000013
1 psi	51.72	68.96	6896	51710	1	0.07
1 atm	760	1013	101300	760000	14.7	1

Volume

	inch³	ft³	liter	cm³	m³
1 inch ³	1	0.00056	0.0163	16.38	0.000016
1 ft ³	1728	1	28.316	28316	0.0283
1 liter	61.02	0.035	1	1000	0.001
1 cm ³	0.061	0.00003	0.001	1	0.000001
1 m ³	61023	35.33	1000	1000000	1



AGILENT VACUUM MEASUREMENT

- 2-3 Features and Benefits
- 4-5 Gauge Selection Card
- 6-7 Applications
- 8-11 Gauge Controller
- 13-21 Transducers
- 22-37 Active Gauges
- 38-39 Cables
- 40-43 Technical Notes



Agilent Technologies

FEATURES AND BENEFITS

Vacuum Measurement for Science and Industry

Agilent vacuum gauges and controllers are reliable, accurate, and cost-effective tools for measuring and controlling vacuum pressure in a wide range of applications.

- Agilent features pressure measurement technology designed for challenging industrial environments: simplicity, rugged design, plus ease of service to insure maximum productivity and uptime in your vacuum system or vacuum process.
- With over 50 years experience in science research, our superior accuracy and stability meets the most demanding scientific requirements.



Rough Gauge Controllers

Reliable, cost-effective solutions for pressure measurement from 1×10^{-3} Torr to 760 Torr, these controllers come with the Agilent TC tube and cable and are pre-calibrated.

- Ready to install and operate
- Two easily configured set points to facilitate critical operations
- Large, bright LED display is easily read across a room or in dimly lit locations



Active Gauge Controllers

These single channel controllers operate the FRG-, PVG-, PCG-, and CDG-series of Active Gauges. Both provide user selectable measurement units and adjustable set point control.

- Easy to set up
- Automatically identify the gauge type when connected
- Adjustable set point control enable critical process steps or operations

User Friendly Interface

UNITS	TORR
SETUP LOCKOUT	ON
AUTO FILAMENT ADVANCE	OFF
ATMOSPHERE VALUE	760
SERIAL MODE	RS232
SERIAL BAUD RATE	19200
RS485 ADDRESS	00

System Setup

#	SETPT	ON&DELAY	OFF&DELAY	EXIT
1	HFIG1	3E-09 0.0	9E-08 0.0	OFF
2	HFIG2	8E-08 0.1	3E-06 2.0	AUTO
3	IMG1	7E-08 0.0	5E-07 0.0	AUTO
4	IMG2	2E-09 0.5	1E-08 0.1	AUTO
5	CNV1	6E+02 0.0	7E+02 0.0	AUTO
6	CNV2	1E		
7	CNV3	8E		
8	CNV4	1E		

Set Points

TORR	
HFIG1	1.8E-5
IMG2	7.1E-7

Large Font

SENSOR SETUP	
SENSOR ID	HFIG1
USER LABEL	HFIG1
SENSOR MODEL	UHV24
AUTO ON IF GAUGE CNV1 IS LESS THAN	5E-3
SENSITIVITY	01.0
EMIS CURRENT(MA)	04.0
GAS CORRECTION	1.00

Sensor Setup

VACUUM MEASUREMENT

XGS-600 Gauge Controller

Intelligent Design & Functionality

- Simultaneous operation of all gauges
 - up to 12
 - < 20 millisecond signal-to-set- point response time
 - Displays up to 8 gauges at one time
- Standard features include:
 - 16 gauge set points
 - fully programmable RS-232/485 serial communications
 - E-beam degas for hot filament gauges
 - pressure unit selection: Torr, mbar, Pascal
 - universal voltage compatibility
 - analog output

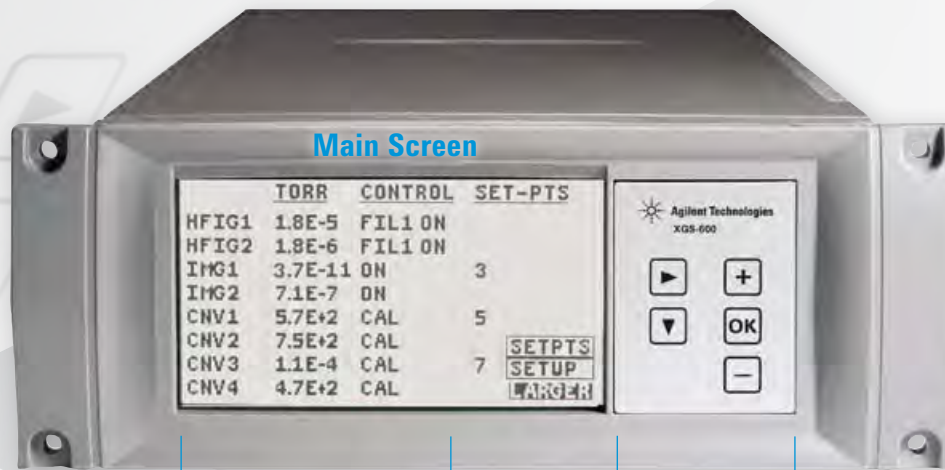

Intuitive screen functions

- Displays up to 8 gauges on one screen
- Customizable gauge labels

Easy key pad navigation

Capacity, Flexibility & Expandability

Only 3 gauge cards operate all Agilent gauges:

- Add a gauge card when needed, simply and quickly
- Save the cost of additional controllers

Simultaneous operation of:

- Up to 4 hot filament gauges plus 4 convection gauges
- Up to 5 inverted magnetron gauges
- Up to 12 convection gauges



AGILENT GAUGE SELECTION CHART

ROUGH VACUUM

atm to 10^{-3}

Transducers

Controller Required

536 ConvecTorr quality accuracy and repeatability

pag. 13



ConvecTorr

Best overall accuracy and repeatability. Secure bayonet connector.

pag. 12



531 Most economical rough gauge

pag. 13



convection board



HIGH VACUUM

10^{-3} to 10^{-9}

572 Glass; most popular general purpose HV gauge (hot filament). Dual filament.

pag. 15



571 Glass; same as 563 without platinum coating

pag. 16



563 Best general purpose HV gauge (hot filament) for overall performance and reliability.

pag. 17



MBA2-200

Small, rugged, wide range

pag. 18



hot filament board



cold cathode board



IMG-100 Most durable HV gauge (cold cathode); fastest response

pag. 19



ULTRA HIGH VACUUM

10^{-9} to 10^{-12}

UHV-24 Most popular UHV gauge (hot filament)

UHV-24p UHV gauge –highest vacuum reading

pag. 21



IMG-300 Most durable, UHV gauge (cold cathode); fastest response

pag. 20



VACUUM MEASUREMENT

Rough Gauge Packages

RGC-100/RGC-150:
Pre-calibrated rough gauges and controller packages



XGS-600 analog board

XGS-600

Multi-gauge Controller

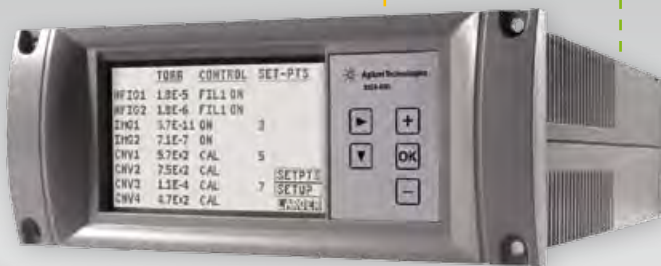

Active Gauge Controller/Display

AGC-100/AGD-100: Low cost active gauge controllers automatically identify the connected gauge



Active Gauges

No Controller Required

PVG-500 Robust, reliable;
general rough vacuum use

pag. 22



CDG-500 Full scale range
options; push-button zeroing
and setpoints

pag. 24



PCG-750 Combo Pirani
and CDG for accuracy and
gas-type independence

pag. 26



FRG-700 Combo Pirani
and IMG – accuracy from
ATM through HV

FRG-720/730 Combo
Pirani and B/A - widest
vacuum measurement range

pag. 28



APPLICATIONS

Physics R&D, Accelerators

- **Synchrotron Light Sources and Beam Lines**
- **Particle Accelerator Rings**

Vacuum gauges are widely used in High Energy Physics, Fusion Technology and general UHV research. Synchrotron Light Sources, Particle Accelerator Rings, UHV Laboratory research, and Fusion reactors need extremely accurate, reliable and cost effective HV and UHV gauges. Agilent offers a full range of vacuum transducers that can be equipped with high function controllers to monitor and control HV and UHV environments. If desired, Agilent also offers “Active Gauges” equipped with on-board controllers that combine highly accurate and compact vacuum measurement and control in the smallest footprint.

Industrial Processes

- **Thin Film Deposition**
 - glass coating equipment (architectural glass, automotive glass, flat panel display substrates)
 - thin film solar cells production (photo-voltaic)
 - optical data media (Compact Discs, Digital Versatile Discs, Magneto Optical Discs)
- **Magnetic storage media (hard discs, read heads)**
- **Surface treatments (functional, decorative)**
- **Optical coating (ophthalmic, precision opto-electronics)**
- **Roll/web coating on films or foils**

In order to assure that a thin film process (PVD/sputtering) is reproducible it is necessary to measure parameters that relate to total gas pressure, which is a function of gas density and temperature, and the partial pressure of the individual gas species. These vacuum parameters should be measured precisely both during pump down to base pressure and during processing as processing often releases gas into the deposition environment.

In crowded chambers at higher pressures (>1mTorr), significant pressure differential can exist in the processing chamber. These pressure differentials can affect film



Plasma vapour deposition (PVD). Worker adjusting the controls of a PVD machine which is being used to coat components (trays at lower centre and lower left) with a thin film metal alloy to provide a wear-resistant coating.

properties such as residual stress, composition, electrical resistivity, etc. In sputter deposition systems, when establishing a plasma, such pressure differences can change the plasma density and thus the sputtering rate, thereby affecting the film composition deposition. In such circumstances several gauges may be used at different locations in the processing chamber to monitor the pressure differences.

- **Device Processing**
 - TV and monitor picture tube manufacture
 - Evacuation and coating of lamps (motorway lighting, beamers)
 - X-Ray tubes & electron devices (CPI, etc)
 - Medical accelerator tubes (medical devices)
 - Lasers, night vision systems
 - Cryogenic processes and instrumentation
 - Infrared detectors (DRS)
- **General Industrial Processes**
 - Vacuum furnaces – Metallurgy

Vacuum Furnaces for Metal Treatment

Brazing, sintering or annealing metals requires an atmosphere free of oxygen. Therefore, such processes are carried out under partial vacuum using inert gas. The vacuum level must be monitored and kept constantly low during the process in order to avoid oxidation of the products. As a result, it is necessary to measure the pressure in the high vacuum furnace near the gas inlet as well as at the vacuum port with high accuracy. Agilent active convection gauges with wide measuring range can detect the pressure at the furnace gas inlet and vacuum port with excellent precision. They are then linked to the system PLC by their serial port with either RS-232 or 485 communication. Based on this, all system pressure levels can be monitored at the main control system. This allows easy monitoring of the system gradient inside the furnace.



VACUUM MEASUREMENT



Scanning electron microscopes, like the one shown here, can “see” details as small as one nanometre – one millionth of a metre!



An NRC researcher uses a liquid chromatography-mass spectrometry system to quantify toxins in shellfish samples.

Nanotechnologies & Semiconductor Manufacturing

- **Electron Microscopy (SEM, TEM)**
- **Focused Ion-beam Systems (FIB) and Surface Analysis**
- **Semiconductor manufacturing**

Modern focused-beam systems such as SEMs, TEMs and FIB's utilize columns that project electrons or ions onto microscopic samples for detailed analysis. End users analyze all types of substances from organic compounds to semiconductor wafers. A key requirement is high sample throughput in order to lower the cost of ownership of these instruments. Agilent offers a full range of high and ultra-high vacuum gauges designed especially for the demanding requirements of SEMs, TEMs and surface analysis systems. Vacuum gauges are also a key component in modern focused-beam systems because the process gas flow can cause significant fluctuations in chamber pressures demanding a wide range of control. Agilent offers a full range of application specific SEM vacuum gauges for easy system integration and flexibility, or gauge controllers for systems that do not have integrated control systems or require dedicated remote read-out.

For the majority of semiconductor manufacturing processes, vacuum system operation usually can be enhanced through good vacuum control to improve reliability, throughput, uptime, contamination control, and process control. For example, a vacuum pump-down or purge cycle often can be shortened without degrading the product, and the time saved can significantly increase throughput. Agilent's complete line of on-board, direct measurement gauges can be easily integrated into existing OEM system controllers through digital or analog control, assuring the ability to meet demanding rapid cycle applications, such as vacuum load locks, in which high gas-load cycling and high tolerable foreline pressures are critical to the success of the process.

Analytical Instrumentation

• Mass Spectrometry

Mass Spectrometry has become an important analytical tool in many industries including pharmaceuticals and life sciences. Thanks to advances in electronics, instrument designers can implement cost-effective, high-performance analytical power in a cost-effective, easy-to-use system. These developments require advanced vacuum systems that are characterized by multi-chamber, high throughput designs on the high quality instruments.

Mass Spectrometers must operate with high accuracy and reliability. Periodic offset adjustment under fine vacuum conditions guarantees that even slightest hints of contamination can be detected. The precise Pirani vacuum transducer controls whether the required vacuum level for zero adjustment is achieved. With its elastic helix filament and the rugged metal housing the transducer is especially durable.

AGILENT GAUGE CONTROLLER

▶ Agilent XGS-600



The XGS-600 Vacuum Gauge Controller provides unprecedented capacity, performance and flexibility in a cost effective, standard half-rack package. A single controller can simultaneously operate up to four hot filament (or four cold cathode) gauges and four convection gauges, up to five cold cathode gauges, or up to twelve convection gauges. Expansion or re-configuration in the field is easy to do. Serial communications (RS-232 or RS-485), sixteen set points,

and universal voltage compatibility are standard in all units. A programmable dot matrix LCD provides display flexibility, and simple screen organization and navigation makes the unit extremely easy to use. Drop down gauge selection automatically sets the emission current, sensitivity and overpressure. The screen displays up to eight gauges and pressures simultaneously, and permits the user to label each gauge. A large-font feature provides visibility from up to 20 feet.

Features

Benefits

<ul style="list-style-type: none"> • Powerful 	<ul style="list-style-type: none"> • A single unit can simultaneously operate up to: <ul style="list-style-type: none"> – 4 BA and 4 convection gauges (or 4 IMG and 4 convection gauges) – 5 ion gauges (5 IMG gauges or 4 hot filament and 1 IMG) – 12 Convection gauges – 12 Agilent Active gauges • 8 Open collector set points • 8 Contact relays • Standard Features in every unit: <ul style="list-style-type: none"> – Serial communication (RS-232 and RS-485), universal voltage, Degas
<ul style="list-style-type: none"> • Flexible 	<ul style="list-style-type: none"> • Operates hot filament, inverted magnetron (cold cathode), convection gauges and all Agilent Active gauges • Can mix and match any gauges in a single unit • Can expand or reconfigure easily in the field • Optional card supports Profibus DP communications protocol
<ul style="list-style-type: none"> • Easy to Use 	<ul style="list-style-type: none"> • Simple screen organization and navigation • Drop down gauge selection automatically sets the emission current, sensitivity and overpressure. • Displays up to 8 gauges simultaneously on one screen • Large font feature allows display of 2 gauges visible from 15-20 feet • Capability of programming your own 5 character gauge label • Set Point Screen: displays and adjusts set points for up to 8 gauges
<ul style="list-style-type: none"> • Fast 	<ul style="list-style-type: none"> • < 20 milliseconds from signal to set point response (Open collector only)
<ul style="list-style-type: none"> • Compact 	<ul style="list-style-type: none"> • All in the impressively small half-rack package

VACUUM MEASUREMENT

XGS-600 Controller operates all Agilent gauges with only 3 gauge cards... convection, hot filament and cold cathode (inverted magnetron)



Laboratory

- Easy to use – can be operated without a manual; screens and menus are easy to follow
- Easy to order – only 3 different controller gauge cards/modules to choose from, everything else is standard
- Easy to adapt – only one gauge card is needed to operate any Agilent gauge of a given type
- Practical – the XGS-600 can be easily reconfigured – it just takes a few minutes to add or remove a gauge card – any Agilent gauge can be operated in one unit
- Convenient – view up to 8 gauges at one time or change the font to view 2 from 15 feet away – all programming is stored in flash memory so no battery backups are needed



Accelerators, Synchrotrons and Other Large Facilities

- Signal response – <20 milliseconds from signal to set point response – ideal for fast acting valves
- Capacity – operates up to 5 IMG gauges in one controller
- Compact – half-rack size saves up to 50-75% of rack space from other controller options
- Operability – fully programmable serial communications with individual gauge labeling; choice of RS-232/485
- Flexibility – combine UHV/HV metrology and IMG interlocking in one unit – ideal in beamline applications

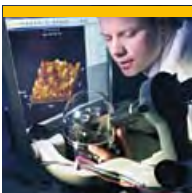

OEM Equipment

- Reliable – The XGS-600 controller has been qualified under demanding test standards; thermal management reduces component stress and provides consistency and durability in performance
- Compact – half-rack size for up to 4 ion gauges and 4 convection gauges in one unit
- Flexibility – operates any Agilent gauge in one controller
- Performance – fully programmable serial communication is standard. Serial response time <2 milliseconds. Displays up to 8 gauges in one screen, gauge labeling. All programming stored in flash memory – no batteries needed
- Contact relay set points for maximum control flexibility and backwards compatibility with legacy controllers

Possible Configurations

Below are examples of ways to configure the XGS-600, but remember, you are not limited to these configurations. The flexibility of this unit allows you to setup the controller with the gauges that suit your needs.



AGILENT GAUGE CONTROLLER

▶ Agilent XGS-600 (Cont'd)

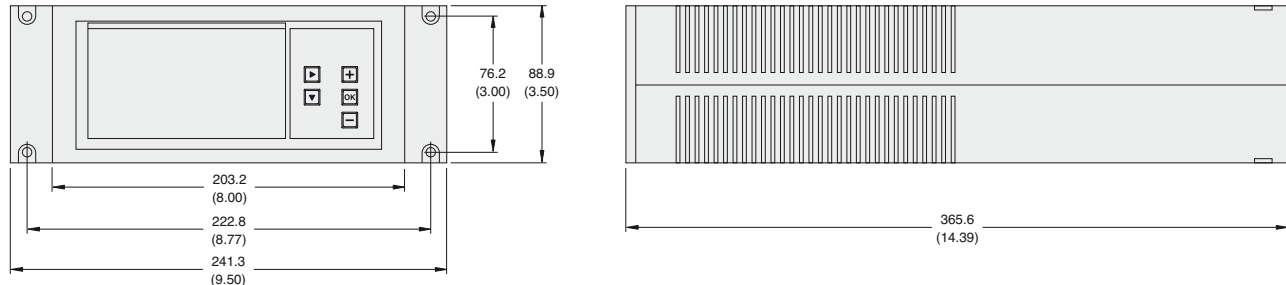

Dimensions: millimeters (inches)

Technical Specifications

User interface	LCD monochrome dot matrix, 240 x 128, white LED backlight; 5 button keypad
Display capability	Up to eight simultaneous channels of pressure measurement, up to a 5 character user label for each; up to two channels in a large font; readable from 15 feet; display updates every 200 msec
Gauge capability	Up to 4 Hot Filament BA gauges including metal, glass, and nude UHV types using the HFIG** cards; up to 5 IMGs* using the IMG* cards; up to 12 rough gauges using the Dual Convection Gauge Cards; up to 12 Active Gauges using Dual Analog Input Cards
Measurement range	1 x 10 ⁻¹¹ Torr to Atm dependent upon card and gauge type selected
Set points - Open collector	Eight normally open setpoints with independently programmable ON and OFF delays, manual override; fast response: 20 msec max (with delay set to 0.0 sec)
Contact relays	Eight normally open or normally closed mechanical relays with 24V @ 2 amp rating, using 25 pin D-sub with same pinout as MultiGauge/SenTorr; 2 set points per relay/channel
Serial communications	RS232 and RS485 (fully programmable)
Analog outputs	1v/dec LOG, 0 – 10 V FS, on each card with 200 msec update rate
I/O control	HFIG** card: Remote gauge ON/OFF, Fil select, DeGAS ON/OFF Inputs, Status Output IMG* card: Remote gauge ON/OFF Input, Status Output Dual Convection Card: Remote CAL inputs, Status Outputs Dual Analog Input Card: Remote CAL Inputs, Status Output
Other	Auto-ON capability for installed ion gauges when at least one convection card is installed Sensitivity, gas correction, emission current (BA gauges only) inputs for ion gauges E-BEAM degas, with auto turn off for BA gauges Selectable air or argon calibration for rough gauges Adjustable atmosphere value for rough gauges Text error messages All data stored in FLASH non-volatile memory requiring no batteries
Power input/Temperature	Worldwide universal power input, 100-240 VAC, 2 A, 50/60 Hz, IEC inlet; 5-40 °C ambient
Regulatory approvals	CE certified and RoHS compliant, BV certified for USA and Canada

*IMG – Inverted Magnetron Gauge

**HFIG – Hot Filament Ion Gauge

VACUUM MEASUREMENT

Ordering Information

Description	Part Number
XGS-600 Vacuum Controller, without cards	XGS600HOMOC0
Configure your XGS-600 Controller with cards – constructing your part number:	XGS600HXMXX
1 Refer to the Gauge Selection Chart to help determine the gauge you need	
2 Choose the number of HFIG** cards you want; place after the "H"; will be 0 to 4	
3 Choose the number of IMG* (cold cathode) cards you want; place after the "M"; will be 0 to 5	
4 Choose the number of Dual Convection Gauge Cards; place after the "C"; each card runs two convection type gauges, will be 0 to 6	
5. If ordering Active Gauge (Analog Input) Cards, add "Ax" to the end of the part number, with the number of cards desired (1 to 6). Each card operates two Active Gauges.	XGS600HXMXXAX

NOTE:

- The XGS-600 has 6 gauge card slots permitting a total of 6 cards.
- Up to four slots can be used for HFIG** cards. If four of these are chosen, one IMG* card or up to two Dual Convection Gauge Cards may be selected also.
- Up to five slots can be used for IMG* cards. If five of these are chosen, no additional gauge cards may be selected.
- All six slots may be used for Dual Convection Gauge Cards or Analog Input Cards.
- HFIG, IMG, and Dual Convection Cards can be used with Dual Analog Input Cards.

Cable Description	Length	Part Number							
		3 ft	10 ft	25 ft	50 ft	65 ft	75 ft	90 ft	100 ft
XGS-600 I/O, with flying leads			R32493010	R32493025	R32493050		Special Order (SO)		
ConvecTorr Gauge, non-bakeable			L91223010	L91223025	L91223050		Special Order (SO)		L91223100
Thermocouple Gauge (531, 536)			L91313010	L91313025	L91313050	SO	L91313075	SO	L91313100
MBA2-200 Gauge			X3203-60006	X3203-60007	X3203-60008	X3203-60009	X3203-60010	N/A	N/A
Glass BA Gauge standard, non-bakeable			R32443010	R32443025	R32443050		Not available over 50 feet –		
UHV-24/UHV-24p standard, non-bakeable			R32453010	R32453025	R32453050		with 10 ft. standard cable, it is possible		
UHV-24/UHV-24p Teflon UHV, bakeable to 250 °C			R32463010	R32463025	R32463050		to order extension up to 250 ft.		
Ion Gauge extension – all hot filament			N/A	N/A	N/A	R32473065	SO	R32473090	SO
IMG-100 Gauge, non-bakeable – may be used with IMG-300			R03113010	R03113025	R03113050	SO	R03113075	SO	R03113100
IMG-300 Gauge, bakeable			R03413010	R03413025	SO	R03413065	SO	SO	R03413100
CT-100 Analog Input Board	R35883003	R35883010	R35883025	R35883050					
FRG-700/PVG/PCG Analog Input Board	R35893003	R35893010	R35893025	R35893050					
CDG Analog Input Board	R35903003	R35903010	R35903025	R35903050					
FRG720/730 Analog Input Board	R35913003	R35913010	R35913025	R35913050					

Accessories

Description	Part Number
Hot Filament Ion Gauge (HFIG) card, field Install	R3075301
Inverted Magnetron Ion Gauge (IMG) Card, field install	R3080301
Dual Convection Gauge Card, field install	R3084301
Dual Analog Input Card, field install	R3487301
Tilt stand accessory	R3124301
Center rack mount kit	L6423301
Off-Center rack mount kit	L6422301
Dual Mount rack mount kit	L6426301

*IMG – Inverted Magnetron Gauge

**HFIG – Hot Filament Ion Gauge

Power Cord Selection

One power cord included with each unit

Description	Part Number
Europe, 10 A / 220-230 VAC, 2.5 meter	656494220
Denmark, 10 A / 220-230 VAC, 2.5 meter	656494225
Switzerland, 10 A / 230 VAC, 2.5 meter	656494235
UK/Ireland, 13 A / 230 VAC, 2.5 meter	656494250
India, 10 A / 220-250 VAC, 2.5 meter	656494245
Israel, 10 A / 230 VAC, 2.5 meter	656494230
Japan, 12 A / 100 VAC, 2.3 meter	656494240
North America, 13 A / 125 VAC, 2.0 meter	656458203

AGILENT GAUGES – ROUGH VACUUM

▶ Agilent ConvecTorr Gauge

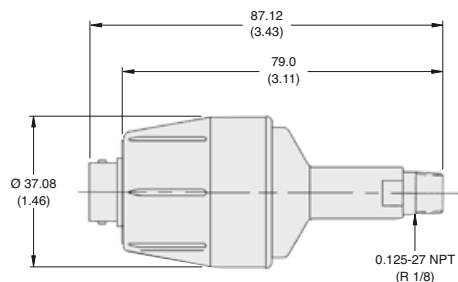

Dimensions: millimeters (inches)

Agilent's unique ConvecTorr gauge is a stainless steel, convection-enhanced thermal gauge, which maintains the sensing element at a constant temperature for superior performance from 10^{-4} Torr to atmospheric pressure. The ConvecTorr features accurate pressure indication over the entire rough vacuum range with extremely fast response time (0.2 seconds) and superior readings at higher vacuum pressures due to enhanced thermal stability. ConvecTorr is ideally suited for a wide range of demanding vacuum applications where accurate pressure monitoring and rapid, repetitive pump downs from atmosphere are required, such as load lock applications or control of a two-stage pump down. And, with excellent sensitivity near atmospheric pressure, ConvecTorr can often save many hours of pumping time when monitoring initial pumping of large vacuum systems. The ConvecTorr, unlike other convection-type gauges, is not affected by system vibration and features a locking bayonet connector. The ConvecTorr offers continuous and repeatable pressure indications between 0 °C and 50 °C. The ConvecTorr is offered with a variety of mounting options and is easily interfaced with Agilent's XGS-600 gauge controller for integration in a complex vacuum system, or for use as a stand-alone pressure measurement tool.

Technical Specifications

Measurement range

1×10^{-4} Torr to atmosphere, 1×10^{-1} to 133 Pascal

Measurement precision

+ 30 % within a pressure decade

Temperature limits

Operating: 0 °C to 50 °C; storage: -15 to 80 °C; bake out: 80 °C with cable disconnected

Pressure response time

Less than 0.2 seconds

Materials

304 stainless steel with platinel filament and ABS housing

Ordering Information

Description	Part Number	Fitting	Shipping Weight kg (lbs)
ConvecTorr Gauge Tube, platinel filament	L9090301	1/8 in. NPT	0.5 (1.0)
	L9090302	Mini-ConFlat	0.5 (1.0)
	L9090303	Cajon 4 VCR (female)	0.5 (1.0)
	L9090305	NW16 KF	0.5 (1.0)
	L9090306	NW25 KF	0.5 (1.0)

VACUUM MEASUREMENT

▶ Agilent 531 Thermocouple and 536 Baffled Thermocouple

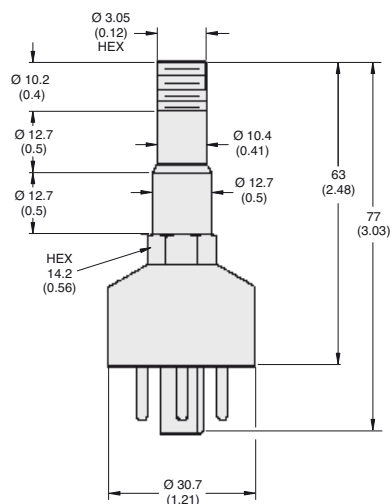

Dimensions: millimeters (inches)

The 531 Thermocouple Gauge Tube is the time-proven, low-cost solution (nickel-plated, soldered construction) for continuous and accurate indication of rough vacuum pressure from 1×10^{-3} to 2.0 Torr (1×10^{-3} mbar to 2.7 mbar). Featuring rugged dependability and consistent operation unaffected by mounting orientation.

The 536 Thermocouple Gauge Tube is a welded 304 stainless steel version of the 531 with an additional baffle that greatly extends the sensor life when exposed to condensable gases in demanding applications. It provides a continuous and repeatable indication of pressures from 1×10^{-3} Torr to 2 Torr (1×10^{-3} mbar to 2.7 mbar). The thermocouple and heater are noble metal to minimize any possible affect of contaminants on gauge performance.

Both gauges are offered in a variety of mounting options and are easily interfaced with Agilent's XGS-600 gauge controller.

Technical Specifications

Measurement range

1×10^{-3} Torr to atmosphere, 1×10^{-1} to 133 Pascal

Temperature limits

Operating: 0 °C to 50 °C; Storage: -15 to 80 °C; bake out: 150 °C with cable disconnected

Pressure response time

Less than 3 seconds

Ordering Information

Description	Part Number	Fitting	Weight kg (lbs)
531 Thermocouple Gauge Tube	F0472301	1/8 in. NPT	0.5 (1.0)
536 Thermocouple Gauge Tube			
Baffled TC tube type 304 stainless steel	L6141303	1/8 in. NPT	0.5 (1.0)
Platinel filament	L6141304	Mini-ConFlat	0.5 (1.0)
	L6141305	Cajon 4 VCR (female)	0.5 (1.0)
	L6141307	NW10 KF	0.5 (1.0)
	L6141308	NW16 KF	0.5 (1.0)
	L6141309	NW25 KF	0.5 (1.0)

AGILENT GAUGES – HIGH VACUUM

▶ Agilent Thermocouple and ConvecTorr Gauge Simulators – Rough Vacuum



ConvecTorr and TC Gauge Simulators are designed to be convenient tools for verifying proper operation of the control unit. For those cases when the target gauge tube cannot be brought to proper pressure levels for true in-situ calibration, the simulator is used to ensure the control unit is calibrated to the average tube. The selectable “Vac” or “Atm” setting facilitates troubleshooting.

TC Gauge Simulator

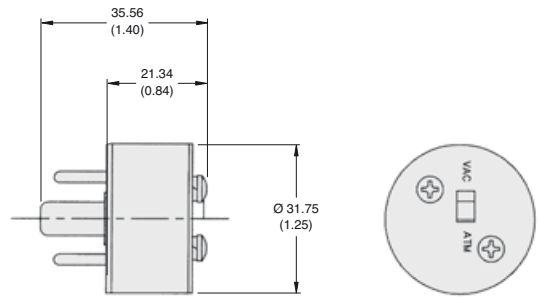

ConvecTorr Simulator

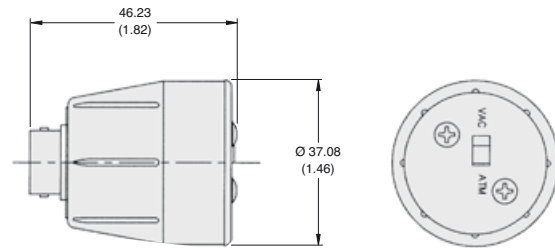

Dimensions: millimeters (inches)

Technical Specifications

Reference pressure

Simulates high vacuum $<10^{-4}$ Torr and atmosphere 760 Torr

Ordering Information

Description	Part Number	Shipping Weight kg (lbs)
ConvecTorr Simulator	L7382301	0.5 (1.0)
TC Simulator	L7383301	0.5 (1.0)

VACUUM MEASUREMENT

▶ Agilent 572 Dual Tungsten Filament Bayard-Alpert Type Standard Range Ionization Gauge Tube

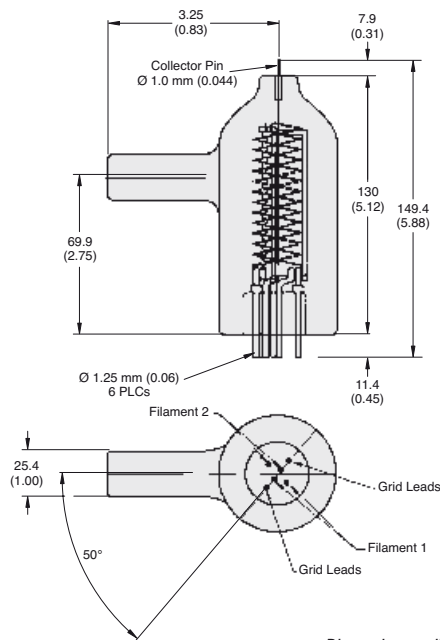

The 572 is a high-performance gauge with a wide range of linear response: from 2×10^{-10} to 10^{-3} Torr. It is designed to withstand long periods of outgassing, and to facilitate simple external switching of filaments without disturbing the vacuum system. The 572 is compatible with virtually all modern hot filament ionization gauge controllers.

Technical Specifications

Sensitivity

$10 \text{ (Torr)}^{-1} \text{ (mbar)}^{-1}$ (typical)

Operating ratings

- 0 VDC to ground (collector)
- + 180 VDC to ground (grid)
- + 30 VDC to ground (filament)

X-Ray limit

2×10^{-10} Torr, (2.6×10^{-10} mbar)

Operating pressure

2×10^{-10} Torr to 1×10^{-3} Torr
(2.7×10^{-10} mbar to 1×10^{-3} mbar)

Ordering Information

Description	Part Number	Fitting	Shipping Weight kg (lbs)
572 Dual-tungsten-filament ionization gauge tube	K7360301	1 in. Glass tubulation	0.5 (1.0)
	K7360302	1 in. Kovar tubulation	0.5 (1.0)
	K7360303	¾ in. Glass tubulation	0.5 (1.0)
	K7360304	¾ in. Kovar tubulation	0.5 (1.0)
	K7360305	NW25 KF	0.5 (1.0)
	K7360306	NW40 KF	0.5 (1.0)
	K7360307	2.75 in. CFF	0.5 (1.0)

AGILENT GAUGES – HIGH VACUUM

▶ Agilent 571 Series Bayard-Alpert Type Standard Range Ionization Gauge Tube

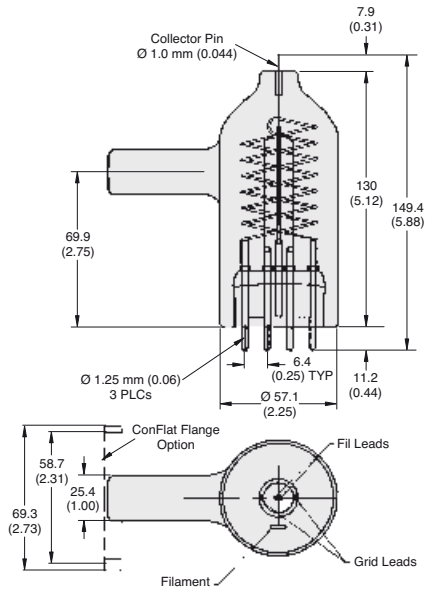

Dimensions: millimeters (inches)

The 571 offers high performance and wide range (2×10^{-10} to 1×10^{-3} Torr). The gauge is rugged; it can withstand long periods of degassing or accidental exposure to atmosphere at operating temperature and still recover its original characteristics.

Technical Specifications

Sensitivity

$6 \text{ (Torr)}^{-1} \text{ (mbar)}^{-1}$ (typical)

Operating ratings

- 0 VDC to ground (collector)
- 0 VDC (shield)
- + 180 VDC to ground (grid)
- + 30 VDC to ground
- 4.0 VAC nominal (filament)

X-Ray limit

4×10^{-10} Torr, (5.2×10^{-10} mbar)

Operating pressure

- 4×10^{-10} Torr to 5×10^{-2} Torr
(5×10^{-10} mbar to 6.7×10^{-2} mbar) (Air)
- 4×10^{-10} Torr to 1×10^{-1} Torr
(5×10^{-10} mbar to 1×10^{-1} mbar) (Argon)

Ordering Information

Description	Part Number	Fitting	Shipping Weight kg (lbs)
571 Ionization tube with thoria-coated iridium filament	K2471301	1 in. Glass tubulation	0.5 (1.0)
	K2471302	1 in. Kovar tubulation	0.5 (1.0)
	K2471304	$\frac{3}{4}$ in. Glass tubulation	0.5 (1.0)
	K2471305	$\frac{3}{4}$ in. Kovar tubulation	0.5 (1.0)
	K2471306	NW25 KF	0.5 (1.0)
	K2471311	NW40 KF	1.0 (2.0)
	K2471303	2.75 in. CFF	1.0 (2.0)
	571 reference ionization tube with thoria-coated iridium filament (sealed off at $\leq 5 \times 10^{-6}$ Torr)	K2471307	–

VACUUM MEASUREMENT

▶ Agilent 563 Series Bayard-Alpert Type Standard Range Ionization Gauge Tube

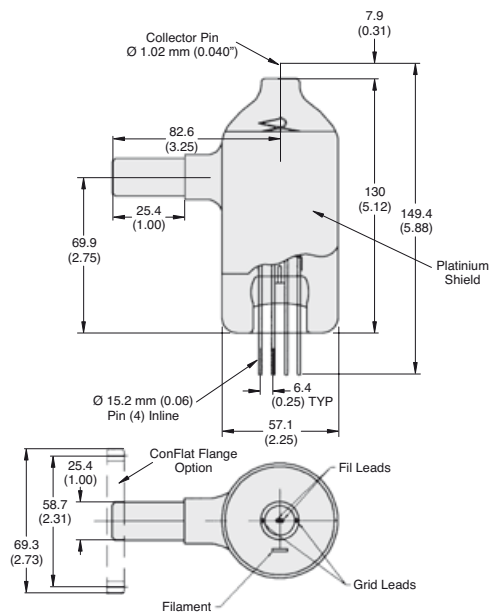

Dimensions: millimeters (inches)

The 563 is a rugged gauge with wide range of linear response: 2×10^{-10} to 1×10^{-3} Torr. The platinum coating inside the bulb shields the gauge elements from electrostatic charges at low pressures and drains off the static charges which can build up at high pressures. The 563 is available in a variety of tubulations.

Technical Specifications

Sensitivity

$10 \text{ (Torr)}^{-1} \text{ (mbar)}^{-1}$ (typical)
Exact measurement available through Agilent STARRS program.
Contact Agilent for details

Operating ratings

- 0 VDC (collector)
- + 180 VDC to ground (grid)
- + 30 VDC to ground
- 5 VAC nominal (filament)

X-Ray limit

2×10^{-10} Torr, (2.6×10^{-10} mbar)

Operating pressure

2×10^{-10} Torr to 1×10^{-3} Torr
(2.7×10^{-10} mbar to 1×10^{-3} mbar)

Ordering Information

Description	Part Number	Fitting	Shipping Weight kg (lbs)
563 Ionization tube with thoria-coated iridium filament	K2466301	1 in. Glass tubulation	0.5 (1.0)
	K2466302	1 in. Kovar tubulation	0.5 (1.0)
	K2466304	$\frac{3}{4}$ in. Glass tubulation	0.5 (1.0)
	K2466305	$\frac{3}{4}$ in. Kovar tubulation	0.5 (1.0)
	K2466306	NW25 KF	0.5 (1.0)
	K2466311	NW40 KF	1.0 (2.0)
	K2466303	2.75 in. CFF	1.0 (2.0)
	563 reference ionization tube with thoria-coated iridium filament (sealed off at $\leq 5 \times 10^{-6}$ Torr)	K2466307	–

AGILENT GAUGES – HIGH VACUUM

► Agilent MBA2-200 Hot Filament Gauges

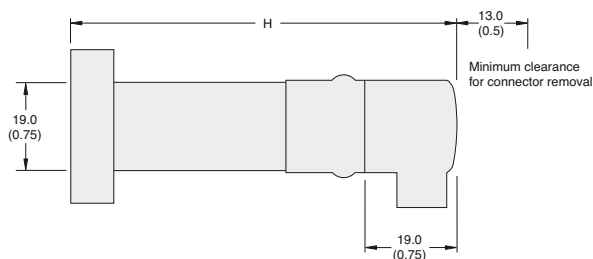

Fitting	H
KF flange	73 (2.9)
ConFlat flange	73 (2.9)

ID Shown - ID of CF & KF Flanges as per international standards

Dimensions: millimeters (inches)

Agilent MBA2-200 Hot Filament Gauges are the smallest Bayard-Alpert style gauges. They are rugged with wide range, they generate low heat and provide good burnout resistance. The MBA2-200 Gauge is small (less than 5% of the volume of a glass gauge) and mounts in almost any location on your system. Its all-metal design eliminates the possibility of breakage. The MBA2-200's unique dual ion collectors and metal envelope provide measurement up to 5×10^{-2} Torr and it has an x ray limit equivalent to that of a glass gauge (3×10^{-10} Torr).

Dual, burn-out resistant, yttria-coated iridium filaments provide long life. As a result, you can avoid unscheduled downtime by using the second filament as a backup until the gauge can be replaced during regular maintenance procedures. In addition, an MBA2-200 gauge requires only 8% of the power of a glass gauge, which means less heat to potentially disturb a process or experiment, cause accidental burns, or melt wiring that may come in contact with the gauge.

Technical Specifications

Mounting orientation	Any
Materials	Vacuum fired, UHV compatible
Envelope	304L stainless steel
Collector	Tungsten
Grid	Tantalum
Filaments	Tungsten or yttria-coated iridium
Weight	0.1 kg (4 oz.) with 1.33 in ConFlat flange (NW 16CF)
Internal volume	10.8 cm ³ (0.66 in. ³)
X ray limit	3×10^{-10} Torr (3.99×10^{-10} mbar, 3.99×10^{-8} Pa) maximum
Sensitivity for N₂	20/Torr (15/mbar, 0.15/Pa)
Electron bombardment degas	3 W at 250 to 330 V
Bakeout temperature, nonoperating	200 °C (392 °F) maximum with cable disconnected 150 °C (302 °F) maximum with cable connected
Operating temperature	0 to 50 °C (32 to 122 °F) ambient, noncondensing
Filament emission current	4 mA maximum 15 mA for electron bombardment degas
Filament bias potential	+30 V
Filament heating voltage	1.2 V (2.3 V maximum)
Filament heating current	2.0 A (3.0 A maximum)
Collector potential	0 V
Grid potential	+180 V

Ordering Information

Description	Part Number
MBA2-200T, Dual Tungsten Fils, NW25	X3203-60000
MBA2-200T, Dual Tungsten Fils, NW40	X3203-60001
MBA2-200T, Dual Tungsten Fils, CFF2.75	X3203-60002
MBA2-200, Dual Yttria-Iridium Fils, NW25	X3203-60003
MBA2-200, Dual Yttria-Iridium Fils, NW40	X3203-60004
MBA2-200, Dual Yttria-Iridium Fils, 2.75Cff	X3203-60005
Cable, 10', MBA2 HFIG, XGS-600	X3203-60006
Cable, 25', MBA2 HFIG, XGS-600	X3203-60007
Cable, 50', MBA2 HFIG, XGS-600	X3203-60008
Cable, 65', MBA2 HFIG, XGS-600	X3203-60009
Cable, 75', MBA2 HFIG, XGS-600	X3203-60010

VACUUM MEASUREMENT

▶ Agilent IMG-100 Inverted Magnetron Gauge

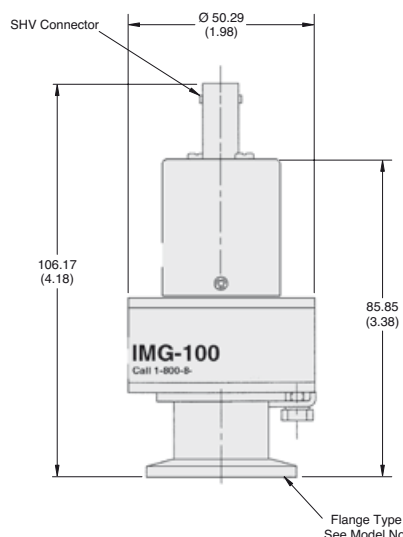

Dimensions: millimeters (inches)

The IMG-100 is a rugged and accurate high vacuum gauge featuring a wide measurement range, fast starting time, good accuracy and superior repeatability in challenging environments. The IMG-100 is ideal for use in industrial applications such as metal deposition, glass coaters, vacuum furnaces, degassing ovens, and electron-beam welders.

The simple design requires no heated filament, so the IMG-100 has an excellent lifetime, is easily serviced, and is tolerant of sudden or frequent exposure to atmosphere. Further, there is less risk of heat from the gauge interfering with a critical experiment or process. The compact size allows flexible installation in any orientation, while the locking SHV high-voltage connector ensures safety and positive electrical contact. A precisely designed magnetic field constrains ionized gas molecules for accurate pressure measurement, so emission of stray electrons and photons is minimized.

The IMG-100 is easily interfaced with Agilent's XGS-600 gauge controller for integration into a variety of vacuum systems, or for use as a stand-alone pressure measurement tool.

Technical Specifications

Measurement range

1×10^{-3} Torr to 5×10^{-9} Torr, 1×10^{-1} Torr to 7×10^{-7} Pascal

Measurement precision

+ xx % within a pressure decade standard, + xx % with STARRS Calibration

Temperature limits

Operating: 0 °C to 80 °C; storage: -15 to 80 °C

Bake out temperature with Conflat flange

150 °C maximum with Cable Disconnected

Ignition response (starting time)

T < 5 seconds at pressures < 1×10^{-6} Torr

Materials exposed to vacuum

300 series stainless steel, nickel, glass (feedthrough)

Operating voltage

3 kilovolts

Sensitivity

2.7 A / Torr + 20% at 5×10^{-6} Torr

Ordering Information

Description	Part Number	Shipping Weight kg (lbs)
IMG-100 NW25 KF	R0310301	1.0 (2.0)
IMG-100 NW40 KF	R0310302	1.0 (2.0)
IMG-100 2.75 in. CFF	R0310303	1.0 (2.0)

AGILENT GAUGES – ULTRA-HIGH VACUUM

▶ Agilent IMG-300 UHV Inverted Magnetron Gauge

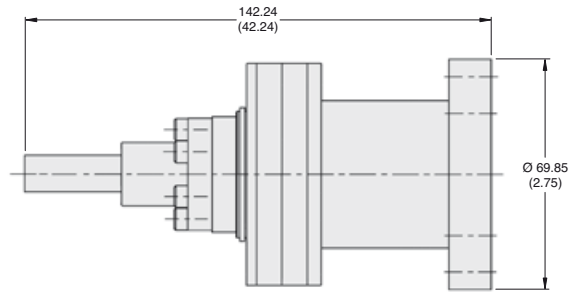

w/2.75 CFF

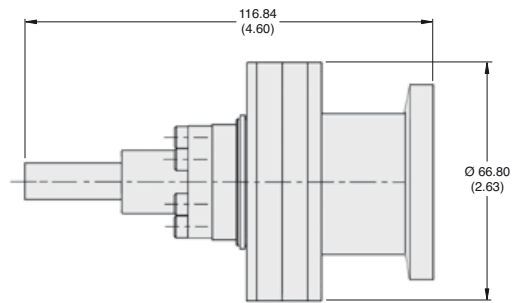

w/NW40 Flange

Dimensions: millimeters (inches)

The IMG-300 inverted magnetron gauge combines excellent ultra-high vacuum measurement capability with fast pressure response. This sensor is optimized for UHV applications such as particle accelerators, synchrotron light beam lines and energy research applications, where stable UHV pressure measurement and fast pressure response are equally critical. Inverted magnetron gauges have no x-ray limit, so the ability to read extremely low pressure is limited only by the number of gas molecules present.

The magnetic design provides superior sensitivity at UHV pressures and ensures starting within 30 seconds at 1×10^{-10} Torr (millibar). With no hot filament, there is minimal outgassing from within the gauge that would degrade absolute accuracy of pressure response, and there is no electron or photon emission to disrupt an experimental process.

The all-metal gauge design is radiation-resistant and bakeable to 250 °C during operation, while the locking SHV high-voltage connector ensures safety and positive electrical contact. Radiation-resistant, bakeable cables are also available. The IMG-300 is easily interfaced with Agilent’s XGS-600 gauge controller for integration into a variety of vacuum systems, or for use as a stand-alone pressure measurement tool.

Technical Specifications

Measurement range

1×10^{-3} Torr to 1×10^{-11} Torr, 1×10^{-1} Torr to 1×10^{-9} Pascal

Measurement precision

+ 50 % within a pressure decade standard,
+ 20 % with STARRS Calibration

Temperature limits

Operating: 0 °C to 250 °C; storage: -15 to 80 °C

Bake out temperature

250 °C maximum with cable and magnet attached

Pressure response time

< 50 milliseconds @ UHV pressures

Ignition response (starting time)

< 30 seconds @ 1×10^{-10} Torr

Operating voltage

3 kilovolts

Materials exposed to vacuum

Stainless steel, nickel, glass, nickel alloy 52

Sensitivity

2 A / Torr + 20% at 5×10^{-6} Torr

Ordering Information

NOTE For information on compatible gauge controllers and cabling, please refer to Multi-Gauge sections of catalog.

Description	Part Number	Fitting	Shipping Weight kg (lbs)
IMG-300	R0343301	2.75 inch CFF	1.0 (2.0)

VACUUM MEASUREMENT

▶ Agilent UHV-24 and UHV-24p Bayard-Alpert Ion Gauge

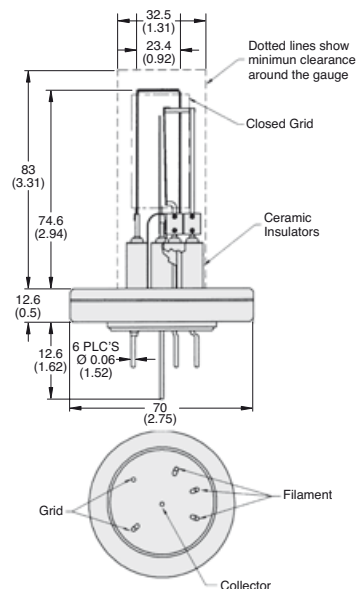

Dimensions: millimeters (inches)

The UHV-24 is a Bayard-Alpert ion gauge using Agilent's etched-grid structure to provide a broad operating pressure range with ionization effectiveness (sensitivity) at least 2 times that of other ionization gauges. The UHV-24 gauges excel in applications where superior measurement accuracy and repeatability of measurement are equally critical. The heated filament provides a constant source of electrons for ionization of gas molecules resulting in accurate and stable results. The precision collector limits X-ray current to a pressure equivalent of approximately 5×10^{-12} Torr (6.7×10^{-12} mbar).

The UHV-24P, an extended range version of the UHV-24, measures pressure from 5×10^{-12} Torr to 1×10^{-3} Torr

(6.7×10^{-12} mbar to 1×10^{-3} mbar). The UHV-24 and 24P feature a 2-3/4-inch ConFlat flange with long-life thoria-coated iridium or tungsten filaments that are easily replaceable in the field.

The UHV-24 and 24P are easily interfaced with Agilent's XGS-600 gauge controller for integration into a variety of vacuum systems, or for use as a stand-alone pressure measurement tool.

Technical Specifications

	UHV-24	UHV-24p
Pressure range	2×10^{-11} to 1×10^{-3} Torr 2×10^{-11} to 1×10^{-3} mbar	5×10^{-12} to 1×10^{-3} Torr 6.7×10^{-12} to 1×10^{-3} mbar
Sensitivity	25 Torr ⁻¹	20 Torr ⁻¹
X-Ray limit	2×10^{-11} Torr	5×10^{-12} Torr (6.7×10^{-12})
Measurement precision	+ 20% of full scale within a pressure decade	
Emission current	4 milliamps default (10 A to 9.99 mA)	
Bake temperature	450 °C with cable connected	
Temperature limits	Operation 0 °C to 250 °C; storage -15 to 80 °C	
Degas	Electron bombardment 400 volts @ 65 mA	
Materials	304 ST, ceramic, Kovar, iridium or tungsten	

Ordering Information

Description	Part Number	Fitting	Shipping Weight kg (lbs)
UHV-24, dual tungsten filaments	9715008	2.75 in. CFF	2.0 (4.0)
UHV-24, dual thoria-iridium filaments	9715007	2.75 in. CFF	2.0 (4.0)
UHV-24P Extended Range, dual tungsten filaments	9715014	2.75 in. CFF	2.0 (4.0)
UHV-24P Extended Range, dual thoria-iridium filaments	9715015	2.75 in. CFF	2.0 (4.0)
Filament replacement kit (thoria-iridium)	9710028		0.5 (1.0)
Filament replacement kit (tungsten filament)	9710018		0.5 (1.0)

ACTIVE GAUGES

▶ Agilent PVG-500/PVG-500S/PVG-502S Pirani Gauges

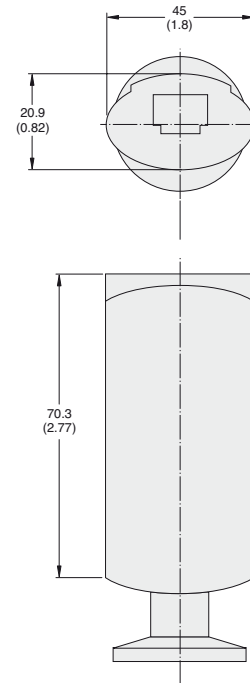

Dimensions: millimeters (inches)

The Agilent PVG-500 series of Pirani gauges provides the ultimate combination of state-of-art technology and ruggedness within a compact design. The PVG-500 series utilizes the most advanced digital Pirani technology combined with a stainless steel sensor design to meet the various needs of the market today.

Applications

- Fore pressure vacuum pressure monitoring
- Controlling high vacuum ionization gauges
- Safety monitoring in vacuum systems
- General vacuum measurement and control in the medium and rough vacuum range

Features

- Compact, rugged aluminum housing that mounts in any orientation with a logarithmic signal output
- Stainless steel sensor cell with metal-sealed feedthrough
- Easy push button ATM and High Vacuum (HV) adjustment
- Nickel filament option
- Optional set points

Benefits

- Ease of integration
- Rugged design for a wide range of applications
- Ease of set-up
- Solution for corrosive applications
- Utilize pressure readings to perform critical operations

VACUUM MEASUREMENT

Technical Specifications

Measurement range (Air, O ₂ , CO, N ₂)	5 x 10 ⁻⁴ to 1000 mbar (3.75 x 10 ⁻⁴ to 750 Torr)		
Accuracy (N ₂)	% of reading	Units	
		±15%	1 x 10 ⁻³ to 100 mbar (1 x 10 ⁻³ to 75 Torr)
		±50%	5 x 10 ⁻⁴ to 1 x 10 ⁻³ mbar (3.75 x 10 ⁻⁴ to 1 x 10 ⁻³ Torr)
		±50%	100 to 1000 mbar (75 to 750 Torr)
Repeatability (Air)	1 x 10 ⁻³ to 100 mbar (1 x 10 ⁻³ to 75 Torr) – % of reading 62%		
Output signal (measurement signal)	Voltage range 0 to 10.3 V	Measurement range 1.9 to 10.0 V	
Voltage vs. pressure	1.286 V/decade, logarithmic		
Error signal	0 to 0.5 V (filament rupture)		
Minimum loaded impedance	10 kΩ, short-circuit proof		
Response time	80 ms		
Adjustment	One tactile switch for both ATM and HV adjustment		
Identification gauge	27 kΩ, referenced to supply common		
	PVG-500	PVG-500S, PVG-502S	
Setpoint	None	2	
Setting range	None	2 x 10 ⁻³ to 500 mbar (1.5 x 10 ⁻³ to 375 Torr)	
Hysteresis	None	10% above lower threshold % of reading	
Relay contact	None	30 VDC / 0.5 ADC floating	
Switching time	None	<20 ms	
Supply voltage	At gauge 14 to 30 VDC	Ripple ≤1 Vpp	Power consumption ≤1 W
Electrical connection	FCC 68/RJ45 appliance connector, 8 poles, male		
Sensor cable	8 poles plus shielding		
Cable length	≤100 meter (330 ft)		
Materials exposed to vacuum	Glass, Ni, NiFe, tungsten (tungsten version)		
Admissible temperature	Operation 5 to 60 °C	Storage –20 to +65 °C	Vacuum Connection ¹ 80 °C
Mounting orientation	Any		
Weight	80 g		

¹ In horizontal mounting position

Ordering Information

Description	Part Number
PVG-500 Pirani, KF16	PVG500KF16
PVG-500 Pirani tungsten filament with setpoints, KF16	PVG500KF16S
PVG-502 Pirani nickel filament with setpoints, KF16 – for corrosive applications	PVG502KF16S
Accessories	
PVG-500 Replacement sensor (tungsten) – recommended for most applications	PVG500KF16RS
PVG-502 Replacement sensor (nickel) – recommended for corrosive applications	PVG502KF16RS

ACTIVE GAUGES

▶ Agilent CDG-500 Capacitance Diaphragm Gauge

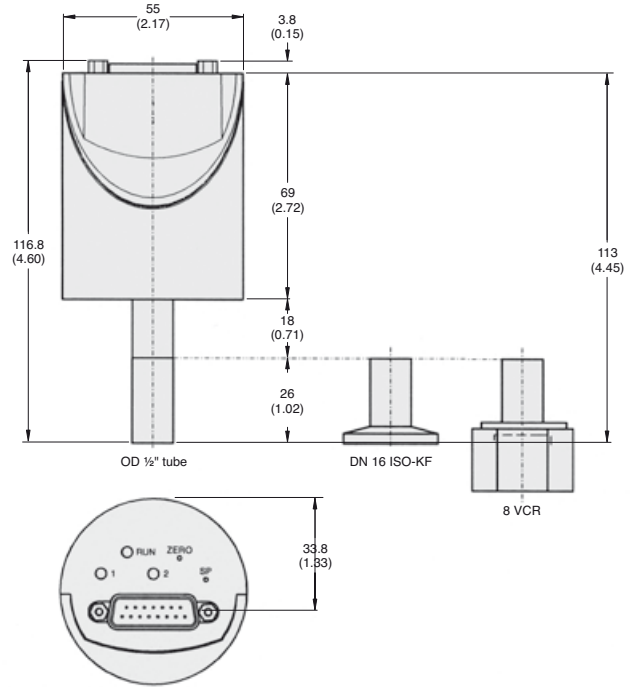

Dimensions: millimeters (inches)

The Agilent CDG-500 series of temperature compensated Capacitance Diaphragm gauges provides a high level of accuracy in the high pressure region. Full scale measurement ranges are available from 1000 Torr to 1 Torr. The CDG-500 series uses a corrosion resistant ultra pure alumina ceramic diaphragm providing exceptional signal stability, fast recovery from atmosphere, short warm-up times and unparalleled robustness.

Features

- Full scale ranges from 1 to 1000 Torr with push button zeroing and optional set point control
- Excellent long term signal stability and repeatability
- Fast recovery from atmospheric pressures and rapid stabilization after start-up
- Corrosion resistant ceramic sensor with sensor shielding protection

Applications

- General thin film and vacuum processes
- Industrial vacuum processes
- Data storage and display manufacturing
- Etch, CVD, PVD and other semiconductor production processes
- Reference sensor for monitoring of test instruments
- Transfer standard for traceability measurements

Benefits

- Ease of integration
- Long term performance – comparable to competitor's heated versions
- Reduces process cycle times
- Application robustness

VACUUM MEASUREMENT

Technical Specifications

Measurement range (full scale)	Torr	1000	100	10	1
	Pa	133,322	13,332	1,333	133
	mbar	1333	133	13.3	1.3
Accuracy ¹	% of reading	0.2	0.2	0.2	0.2
Temperature effect					
on zero	% F.S./°C	0.005	0.005	0.005	0.015
on span	% of reading/°C	0.01	0.01	0.01	0.01
Resolution	% F.S.	0.003	0.003	0.003	0.003
Pressure, maximum	kPa (absolute)	400	260	260	260
Lowest reading	% F.S.	0.01			
Lowest suggested reading	% F.S.	0.05			
Lowest suggested control pressure	% F.S.	0.05			
Temperature		Operation (ambient) 5 to 50 °C	Bakeout (at flange) ² ≤ 110 °C	Storage –40 to 65 °C	
Supply voltage			14 to 30 VDC		
Power consumption			≤ 1 W		
Output signal (analog)			0 to 10 VDC		
Response time			30 ms		
Degree of protection			IP30		
Electrical connection			D-sub, 15 pole, male		
Setpoints ³ – Two (2) setpoints, SP 1 and SP 2		Relay Contact 30 VDC; ≤ 0.5 ADC		Hysteresis 1% of F.S	
Materials exposed to vacuum		Aluminum oxide ceramic (Al ₂ O ₃), Vacon 70 ⁴ , stainless steel (AISI 316L ⁵) AgCuTi hard solder, sealing glass			

¹ Non-linearity, hysteresis, repeatability at 25 °C ambient operating temperature without temperature effects after 2 hours operation

² Non operating

³ CDG-500 setpoint versions only

⁴ 28% Ni, 23% Co, 49% Fe

⁵ 18% Cr, 10% Ni, 3% Mo, 69% Fe

Ordering Information

Description	Part Number	
	KF16	VCR8
CDG-500 Capacitance Diaphragm Gauge (1000 Torr)	CDG500T1000KF16	CDG500T1000VCR8
CDG-500 Capacitance Diaphragm Gauge (100 Torr)	CDG500T0100KF16	CDG500T0100VCR8
CDG-500 Capacitance Diaphragm Gauge (10 Torr)	CDG500T0010KF16	CDG500T0010VCR8
CDG-500 Capacitance Diaphragm Gauge (1 Torr)	CDG500T0001KF16	CDG500T0001VCR8
CDG-500 Capacitance Diaphragm Gauge (1000 Torr) with setpoints	CDG500T1000KF16S	CDG500T1000VCR8S
CDG-500 Capacitance Diaphragm Gauge (100 Torr) with setpoints	CDG500T0100KF16S	CDG500T0100VCR8S
CDG-500 Capacitance Diaphragm Gauge (10 Torr) with setpoints	CDG500T0010KF16S	CDG500T0010VCR8S
CDG-500 Capacitance Diaphragm Gauge (1 Torr) with setpoints	CDG500T0001KF16S	CDG500T0001VCR8S

ACTIVE GAUGES

▶ Agilent PCG-750/PCG-752 Pirani/Capacitance Diaphragm Gauges



Profibus Version

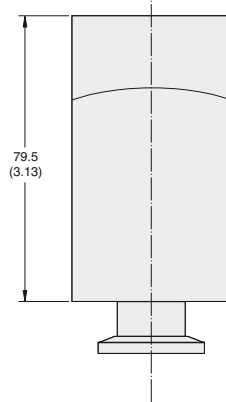
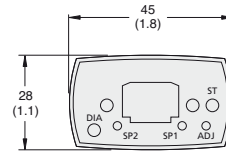

Dimensions: millimeters (inches)

The Agilent PCG-750 series of Pirani Capacitance Diaphragm gauges combines Agilent's Pirani and ceramic capacitance diaphragm sensors into a single design that provides gas-type independence with increased accuracy from Atm to 5×10^{-5} mbar (3.8×10^{-5} Torr).

Features

- High accuracy and reproducibility at atmosphere
- Fast atmospheric detection
- Gas-type independent above 10 mbar
- Compact, rugged housing that mounts in any orientation with a logarithmic signal output
- Set point control
- Exchangeable plug and play sensor
- Nickel filament option
- Bright color LCD display option

Applications

- Fore pressure vacuum monitoring
- Safety monitoring in vacuum systems
- General vacuum measurement and control in the medium and rough vacuum range
- Load lock control

Benefits

- Reliable atmospheric pressure monitoring
- Shortens process cycle times
- Allows safe venting with any gas mixture
- Ease of integration
- Utilize pressure readings to perform critical operations
- Easy to repair with low cost of ownership
- Solution for corrosive applications
- Monitor pressure readings easily

VACUUM MEASUREMENT

Technical Specifications

Measurement range (Air, O ₂ , CO, N ₂)		5 x 10 ⁻⁵ to 1500 mbar (3.8 x 10 ⁻⁵ to 1125 Torr)				
Accuracy	% of reading	Units				
	±50%	5 x 10 ⁻⁵ to 1 x 10 ⁻³ mbar (3.75 Torr to 1 x 10 ⁻³ Torr)				
	±15%	1 x 10 ⁻³ to 100 mbar (1 x 10 ⁻³ to 75 Torr)				
	±5%	100 to 950 mbar (75 to 712.5 Torr)				
	±2.5%	950 to 1050 mbar (712.5 to 787.5 Torr)				
Repeatability (N ₂)	% of reading	Units				
	±2.5%	1 x 10 ⁻³ to 1100 mbar (1 x 10 ⁻³ to 825 Torr)				
Admissible pressure		≤ 5 bar absolute				
Burst pressure		≤ 10 bar absolute				
Admissible temperature	Operation (ambient) 10 to 50 °C	Storage -20 to +65 °C			Bakeout flange ≤ 80 °C	
Supply voltage		15 to 30 VDC @ < 0.8 A				
Output signal		0 to 10.23 V				
Measurement range		0.61 to 10.23 V				
Voltage vs. pressure		1.286 V/decade				
Load impedance		> 10 kΩ				
Setpoint relay (2)	Range (N₂)	Relay Contact	Hysteresis	Contact Rating Solid state relays	Contact Rating Mechanical relays	Switching time
	5 x 10 ⁻⁵ to 1500 mbar	n.o., potential free	10 % of threshold	≤30VDC/ ≤0.3ADC	≤30VDC/ ≤1ADC	≤30 ms
Interface (digital)		RS232C				
Power connection		FCC, 8 pin				
Materials exposed to vacuum		PCG-750: W, Ni, NiFe, Al ₂ O ₃ , SnAg, SS, glass PCG752: Ni, NiFe, Al ₂ O ₃ , SnAg, SS, glass				

Ordering Information

Description	Part Number
PCG-750 Pirani/CDG combination gauge (tungsten), KF16	PCG750KF16
PCG-750 Pirani/CDG combination gauge (tungsten) with setpoints and display, KF16 (mbar)	PCG750KF16SD1
PCG-750 Pirani/CDG combination gauge (tungsten) with setpoints and display, KF16 (Torr)	PCG750KF16SD2
PCG-750 Pirani/CDG combination gauge (tungsten) with setpoints and display, KF16 (pascal)	PCG750KF16SD3
PCG-750 Pirani/CDG combination gauge (tungsten) with setpoints and Profibus, KF16 (mbar)	PCG750KF16SP
PCG-752 Pirani/CDG combination gauge (nickel), KF16	PCG752KF16
PCG-752 Pirani/CDG combination gauge (nickel) with setpoints and display, KF16 (mbar)	PCG752KF16SD1
PCG-752 Pirani/CDG combination gauge (nickel) with setpoints and display, KF16 (Torr)	PCG752KF16SD2
PCG-752 Pirani/CDG combination gauge (nickel) with setpoints and display, KF16 (pascal)	PCG752KF16SD3
PCG-752 Pirani/CDG combination gauge (nickel) with setpoints and Profibus, KF16 (mbar)	PCG752KF16SP
Accessories	
PCG-750 (tungsten) Replacement sensor –recommended for most applications	PCG750KF16RS
PCG-752 (nickel) Replacement sensor –recommended for corrosive applications	PCG752KF16RS

ACTIVE GAUGES

▶ Agilent FRG-700/FRG-702 Full Range Pirani/Inverted Magnetron Gauges

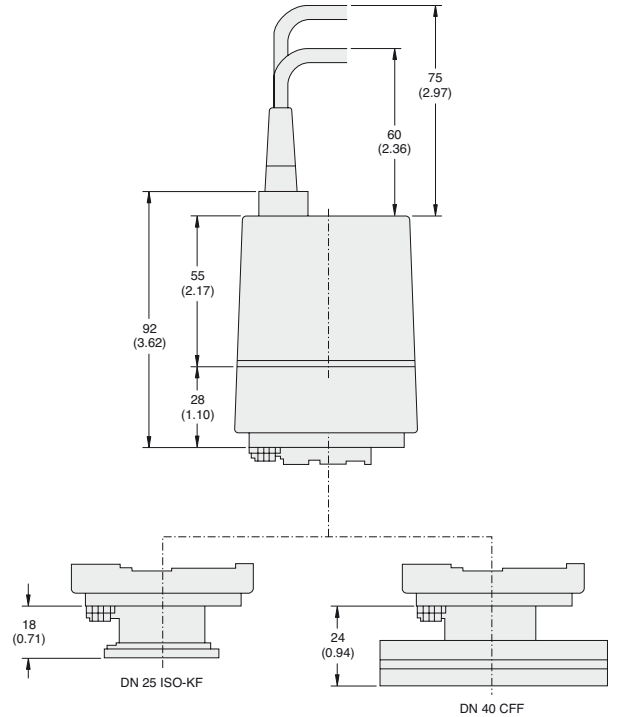

Dimensions: millimeters (inches)

The Agilent FRG-700 and FRG-702 (all metal version) are full range gauges that provide two measuring technologies in a single, compact and economical package to measure process and base pressure from 5×10^{-9} mbar to atmosphere (3.8×10^{-9} Torr to atmosphere). The single, compact unit with one logarithmic analog output signal significantly reduces the complexity of installation, setup and integration. The benefit is reduced cost and reduction in valuable space requirements

Applications

- High vacuum pressure monitoring
- Base pressure for evaporation and sputtering systems
- General vacuum measurement and control in the medium and high vacuum range

Features

- Combination gauge – inverted magnetron and Pirani, with wide measurement range from 5×10^{-9} mbar to atmosphere
- No filament to burn out; easy to clean
- Excellent ignition properties
- Can be operated by a Agilent V-81 or V-301 rack controller and used with the TPS Compact and MiniTask
- LED indicator for high voltage on

Benefits

- Measures 9 decades using 1 compact gauge, 1 connection, 1 sensor cable and 1 A/D converter; reduces complexity and cost
- Low maintenance and reduced cost
- Rapid start-up
- Greatly reduces cost and space requirements
- Provides quick visual indication of status

VACUUM MEASUREMENT

Technical Specifications

Measurement range	5 x 10 ⁻⁹ to 1000 mbar (3.8 x 10 ⁻⁹ to 760 Torr)			
Accuracy	±30% of reading, typical			
Repeatability	±5% of reading, typical			
Mounting orientation	Any			
Admissible temperature	Operation (ambient) 5 to 55 °C	Storage -40 to +65 °C	Bake-out* (w/o electronics) 150 °C	Filament temperature (Pirani) 120 °C
Supply voltage	At gauge 15 to 30 VDC		Ripple ≤1 Vpp	Power consumption ≤2 W
Output signal (measurement signal)	Voltage range 0 to 10.5 V		Measurement range 1.82 to 8.6 V	
Voltage vs. pressure	0.6 V/decade, logarithmic			
Error signal	<0.5 V (no supply), >9.5 V (Pirani sensor, filament rupture)			
Minimum loaded impedance	10 kΩ, short-circuit proof			
Response time	<10 ms (@ p> 10 ⁻⁶ mbar), ≈1000 ms (@ p= 10 ⁻⁸ mbar)			
Identification gauge	85 kΩ, referenced to supply common			
Status	Pirani-only mode 0 V (low)	Combined Pirani/cold cathode mode 15 V to 30 (high)		LED LED green high voltage on
Electrical connection	FCC 68 appliance connector, 8 poles, female			
Sensor cable	8 poles plus shielding			
Maximum cable length	≤50 m			
Operating voltage/current	≤3.3 kV/≤500 A			
Materials exposed to vacuum	FRG-700 - SS, Al ₂ O ₃ , FPM75, Mo, Ni, Au, W		FRG-702 - SS, Al ₂ O ₃ , FPM75, Mo, Ni, Au, W	
Internal volume	≈ 20 cm ³			
Weight	FRG-700 - DN 25 ISO-KF ≈700g, DN 40 CF ≈980 g FRG-702 - DN 25 ISO-KF ≈730g, DN 40 CF ≈1010 g			
Standards	EN 61000-6-2, EN 61000-6-3, EN 61010-1			

* Without electronics and magnetic shielding.

Ordering Information

Description	Part Number
FRG-700 Pirani/IMG Combination Gauge, KF 25	FRG700KF25
FRG-700 Pirani/IMG Combination Gauge, DN40 CF	FRG700CF35
FRG-702 Pirani/IMG Combination Gauge, KF25, All Metal – bakeable	FRG702KF25
FRG-702 Pirani/IMG Combination Gauge, DN40 CF, All Metal – bakeable	FRG702CF35
Accessories	
FRG-700 Gauge Maintenance Kit	FRG700MAINT
FRG-700 Gauge Repair Kit	FRG700REPR
FRG-702 Gauge Maintenance Kit	FRG702MAINT
FRG-702 Gauge Repair Kit	FRG702REPR
FRG-700/702 Magnetic Shielding	FRG700MSHD
FRG-700 Cable, Gauge to AG Turbo Controller, 3M	9699960
FRG-700 Cable, Gauge to AG Turbo Controller, 5M	9699961

ACTIVE GAUGES

▶ Agilent FRG-720/FRG-730 Full Range Pirani/Bayard-Alpert Gauges

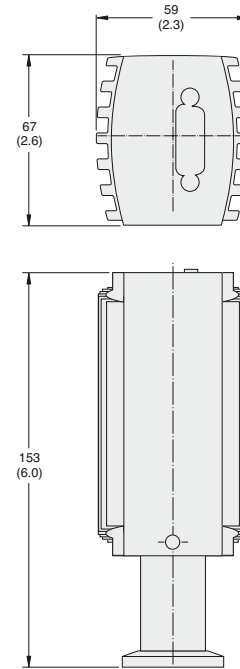

Dimensions: millimeters (inches)

The Agilent FRG-720 and FRG-730 combine Agilent's Pirani and Bayard-Alpert sensor into a single compact design that provides measuring capability from 5×10^{-10} mbar to atmosphere (3.8×10^{-10} Torr to atmosphere). Combining these two technologies into a single unit reduces complexity and integration challenges while protecting the Bayard-Alpert sensor from premature burnout.

Applications

- Wide range from industrial coating and semiconductor processing to research and laboratory environments
- General vacuum measurement and control in the low to ultra-high vacuum range

Features

- Combination gauge – Bayard-Alpert and Pirani
- Pirani interlock
- Long-life yttrium oxide coated iridium filament
- Set point control
- LCD display option
- Profibus communication option

Benefits

- Wide measurement range from 5×10^{-10} mbar to atmosphere
- Protects Bayard-Alpert sensor from premature burnout and contamination effects from high pressure operation
- Rugged design for a wide range of applications
- Utilize pressure readings to perform critical operations
- Monitor pressure readings easily
- Ease of network integration

VACUUM MEASUREMENT

Technical Specifications

Measurement range (Air, O ₂ , CO, N ₂)		5 x 10 ⁻¹⁰ to 1000 mbar (3.8 x 10 ⁻¹⁰ to 760 Torr)			
Accuracy		10 ⁻⁸ to 10 ⁻² mbar/Torr – ±15% of reading			
Repeatability		10 ⁻⁸ to 10 ⁻² mbar/Torr – ±5% of reading			
Degas		p < 7.2 x 10 ⁻⁶ mbar – electron bombardment, max. 3 min			
Pressure, maximum		2 bar absolute			
Temperature		Operation (ambient)	Storage	Bakeout at flange w/extension	Bakeout at flange wo/extension
		0 to 50 °C	-20 to +70 °C	150 °C	80 °C
					Bakeout w/electronics removed
					150 °C
Supply voltage		20 to 28 VDC, 1.4 A on startup for 200 msec, 0.8 A operating			
Output signal analog		0 to 10 V			
Measurement range		0.774 to 10.0 V			
Voltage vs. pressure		0.75 V/decade			
Error signal		0.3/0.5 V			
Minimum loaded impedance		10 kΩ			
Communications interface		RS-232C			
Electrical connection		D-sub, 15 pin, male			
Maximum cable length		100 m (330 ft)			
Materials exposed to vacuum		Yt ₂ O ₃ , Ir, Pt, Mo, Cu, W, NiFe, NiCr, stainless steel, glass			
Internal volume	KF/CF	24 cm ³ (1.46 in ³)/34 cm ³ (2.1 in ³)			
Weight	KF/CF	285 g/550 g			
Protection type		IP30			
Setpoint relays (1) for FRG-730		Range	Relay Contact	Hysteresis	Contact rating
		1 x 10 ⁻⁹ to 100 mbar	n.o., potential free	10 % of reading	30 V/0.5 A DC
Profibus option					
Baud rates		9.6/19.2/93.75/187.5/500 kBaud; 1.5/12 mBaud			
Address		2 switches (address 00 – 127) or network programmable			
Digital functions		Read pressure, select units (Torr, mbar, Pa); degas function, Pirani full scale adjust; monitor gauge status; safe state allows definition of behavior in case of error; detailed alarm and warning information			
Analog functions		0 to 10 V analog output pressure indication; two setpoint relays A + B			
Setpoint relays (2)		Range	Relay Contact	Hysteresis	Contact rating
		1 x 10 ⁻⁹ to 100 mbar	n.o., potential free	10 % of reading	60 V/0.5 A DC
Connector for Profibus DP		D-sub, 9 pin, female			

Ordering Information

Description	Part Number	
	KF25	CF35
FRG-720 Pirani/Bayard Alpert combination gauge – single filament	FRG720KF25	FRG720CF35
with display	FRG720KF25D	FRG720CF35D
with setpoints and Profibus	FRG720KF25SP	FRG720CF35SP
FRG-730 Pirani/Bayard Alpert combination gauge – dual filaments w/set pts	FRG730KF25S	FRG730CF35S
FRG-730 Pirani/Bayard Alpert combination gauge – dual filaments w/set pts. and display	FRG730KF25SD	FRG730CF35SD
FRG-730 Pirani/Bayard Alpert combination gauge – dual filaments w/set pts and Profibus	FRG730KF25SP	FRG730CF35SP

Accessories

FRG-720 Replacement sensor–KF25	FRG720KF25RS
FRG-720 Replacement sensor–CF35	FRG720CF35RS
FRG-730 (dual filaments)–KF25 Replacement sensor	FRG730KF25RS
FRG-730 (dual filaments)–CF35 Replacement sensor	FRG730CF35RS
FRG-720/730 Baffle	FRG720BFL
FRG-720/730 Power Supply 24 V DC/RS232C	FRG720PWR
FRG-720/730 Bakeout extension, 100mm	FRG720BKE

ACTIVE GAUGES

▶ Agilent AGC-100 Active Gauge Controller/ AGD-100 Active Gauge Display

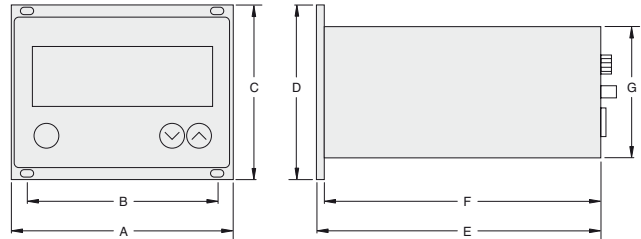

	A	B	C	D	E	F	G
AGC-100	106 (4.2)	91 (3.6)	78 3.1	84 3.3	210 8.3	207 8.2	67 (2.6)
AGD-100	106 (4.2)	91 (3.6)	78 (3.1)	84 (3.3)	136 (5.3)	132 5.2	62 (2.4)

Dimensions: millimeters (inches)

AGC-100 is single channel controller compatible with the FRG 7xx, PVG-5xx, PCG-75x and CDG-500 series of active gauges and automatically identifies the active gauge connected.

Features

- Automatic identification of Agilent active gauges
- User selectable pressure units (mbar, Torr, Pascal)
- Adjustable setpoint control

AGD-100 is a low cost single channel display option for the FRG-700/702, PVG-5xx and PCG-75x series of active gauges. Both units have user selectable measurement unit (mbar, Torr, Pascal), and adjustable setpoint control.

Benefits

- Ease of setup
- Global compatibility
- Utilize pressure readings to perform critical operations

VACUUM MEASUREMENT

Technical Specifications

Measurement channels	One (1)
Measurement range	2×10^{-10} to 1500 mbar (1.5×10^{-10} to 1125 Torr)
Measurement unit (selectable)	mbar, Torr, Pascal
Rate	10/sec
A/D converter	16 bit
Setpoints	
Setpoint relays	One (1)
Channel assignment	One (1)
Relay contact	Potential free change over contact
Hysteresis	Adjustable
Contact rating	30 VAC/1A; 60 VDC/0.5A
Connector	D-Sub, 9 pin, male
Display	LED
Analog output	
Range	0-10.3 V, sensor analog output signal
Connector	D-Sub, 9 pin, male
Supply	90-250 V, 50/60 Hz
Consumption	#30W
Operation temperature (ambient)	5 to 50 °C
Digital interface (AGC-100 only)	RS-232C ; D-Sub, 9 pin, female

Ordering Information

Description	Part Number
Active Gauge Controller for FRG 7xx, PVG-5xx, PCG-75x and CDG-500 Series	AGC100
Gauge display for FRG-700/702 and PVG-5xx and PCG-75x Series	AGD100
Accessories	
Front adapter for controller, rack adaptor, 3u	AGC100ADPT
Cable (FRG700/702, PVG, PCG) – 3 m (9.9 ft)	AGCCBL103
Cable (FRG700/702, PVG, PCG) – 5 m (16.4 ft)	AGCCBL105
Cable (FRG700/702, PVG, PCG) – 10 m (33 ft)	AGCCBL110
Cable (FRG720/730) – 3 m (9.9 ft)	AGCCBL203
Cable (FRG720/730) – 5 m (16.4 ft)	AGCCBL205
Cable (FRG720/730) – 10 m (33 ft)	AGCCBL210
Cable (CDG500) – 3 m (9.9 ft)	AGCCBL303
Cable (CDG500) – 5 m (16.4 ft)	AGCCBL305
Cable (CDG500) – 10 m (33 ft)	AGCCBL310
Power Cord Selection One power cord included with each unit	
Europe, 10 A/220-230 VAC, 2.5 meter	656494220
Denmark, 10 A/220-230 VAC, 2.5 meter	656494225
Switzerland, 10 A/230 VAC, 2.5 meter	656494235
UK/Ireland, 13 A/230 VAC, 2.5 meter	656494250
India, 10 A/220-250 VAC, 2.5 meter	656494245
Israel, 10 A/230 VAC, 2.5 meter	656494230
Japan, 12 A/100 VAC, 2.3 meter	656494240
North America, 13 A/125 VAC, 2.0 meter	656458203

ACTIVE GAUGES

▶ Agilent RGC-100 Rough Gauge Controller

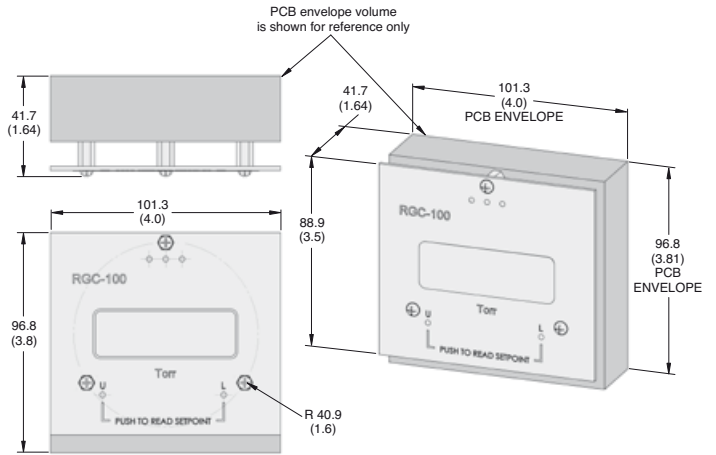

Dimensions: millimeters (inches)

The Agilent RGC-100 Rough Gauge Controller is a cost effective solution for pressure measurements in the 1×10^{-3} Torr to 760 Torr region.

The RGC-100 package includes the TC tube, sensor cable and power supply to provide a pre-calibrated turnkey rough vacuum solution.

Applications

- General vacuum measurement and control in the rough vacuum range
- Monitor forelines, chamber evacuation and crossover to high vacuum pumps

Features

- Thermocouple gauge – Agilent 531 – and controller are pre-calibrated as a set at the factory
- Runs on 100-230 VAC, 50/60 Hz and displays in Torr or mbar
- Large bright LED display
- No moving parts
- Optional set point control, analog output, RS232 communications
- Economical vacuum gauge

Benefits

- No calibration required at initial setup
- Globally compatible
- Easily read from across a room, or in dimly lit locations
- Shock resistant and requires infrequent calibration
- Easily integrated
- Ideal choice for integrators

NOTE Factory calibration is performed using equipment under NIST Standards. Calibration certificates are not available with these products.

VACUUM MEASUREMENT

Technical Specifications

Measurement range	1.3 x 10 ⁻³ to 1000 mbar (1.0 x 10 ⁻³ to 760 Torr)	
Accuracy	% of reading	Units
	±10%	1.3 x 10 ⁻³ to 1.3 mbar (1 milliTorr to 1 Torr)
	±15%	1.3 to 13.3 mbar (1 to 10 Torr)
	±50%	13.3 to 213 mbar (10 to 160 Torr)
	±25%	213 to 1000 mbar (160 Torr to 760 Torr)
Vacuum fitting	½ inch NPT-M	
Interface cable length	10 ft.	
Sensor	Agilent 531 TC gauge tube	
Display	See below	
Dimensions	Mounts in 2.66 inch panel hole with 3 screws on 1.60 inch radius	
Supply voltage	100-240 VAC, 50/60 Hz	
Standards	CE, ROHS compliant	
Optional setpoint controls	7 A, 250 V	
Optional communication interface	RS-232	
Optional analog output	0-5 VDC	

Ordering Information

Description	Part Number
RGC-100 Rough Gauge Controller (mbar)	RGC100M
RGC-100 Rough Gauge Controller (Torr)	RGC100T
RGC-100 Rough Gauge Controller with setpoints and RS232 (mbar)	RGC100MS
RGC-100 Rough Gauge Controller with setpoints and RS232 (Torr)	RGC100TS
RGC-100, 1.33" CFF TC, mbar, Controller	RGC100MCF
RGC-100, KF16 536 TC, mbar, Controller	RGC100MKF16
RGC-100, KF25 536 TC, mbar, Controller	RGC100MKF25
RGC-100, 1.33" CFF TC, mbar, SPs, Controller	RGC100MSCF
RGC-100, KF16 536 TC, mbar, SPs, Controller	RGC100MSKF16
RGC-100, KF25 536 TC, mbar, SPs, Controller	RGC100MSKF25
RGC-100, 1.33" CFF TC, Torr, Controller	RGC100TCF
RGC-100, KF16 536 TC, Torr, Controller	RGC100TKF16
RGC-100, KF25 536 TC, Torr, Controller	RGC100TKF25
RGC-100, 1.33" CFF TC, Torr, SPs, Controller	RGC100TSCF
RGC-100, KF16 536 TC, Torr, SPs, Controller	RGC100TSKF16
RGC-100, KF25 536 TC, Torr, SPs, Controller	RGC100TSKF25

Accessories

Replacement sensors	
½ inch NPT-M	F0472303
KF16	L6141308
KF25	L6141309
1.33 in CFF	L6141304

NOTE All part number with "S" include the optional set points, RS232, and analog output.

ACTIVE GAUGES

▶ Agilent RGC-150 Rough Gauge Controller

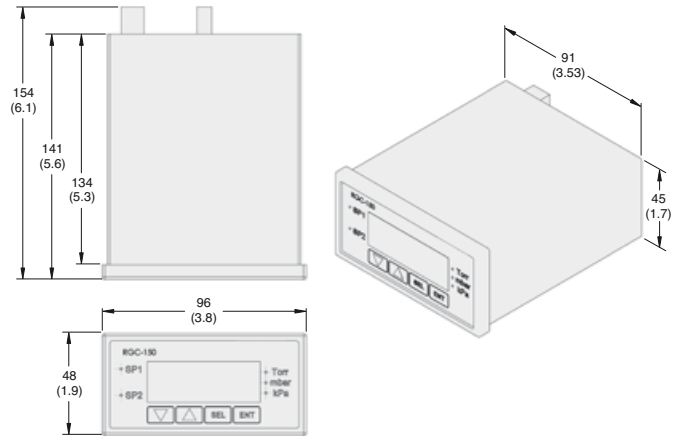

Dimensions: millimeters (inches)

The Agilent RGC-150 Rough Gauge Controller is a cost effective solution for pressure measurements in the 1×10^{-3} Torr to 760 Torr region.

The RGC-150 package includes the TC tube, sensor cable and power supply to provide a pre-calibrated turnkey rough vacuum solution.

Applications

- General vacuum measurement and control in the rough vacuum range
- Monitor forelines, chamber evacuation and crossover to high vacuum pumps

Features

- Thermocouple gauge – Agilent 531 – and controller are pre-calibrated as a set at the factory
- Two easily configured set points
- Runs on 100-230 VAC, 50/60 Hz and displays in Torr, mbar and kPa
- Large bright LED display
- Optional Ethernet connection and software that allows for remote monitoring through a web browser

Benefits

- No calibration required at initial setup
- Utilize pressure readings to perform critical operations
- Globally compatible
- Easily read from across a room or in dimly lit locations
- Monitor vacuum performance from a remote location

NOTE Factory calibration is performed using equipment under NIST Standards. Calibration certificates are not available with these products.

VACUUM MEASUREMENT

Technical Specifications

Measurement range	1.3 x 10 ⁻³ to 1000 mbar (1.0 x 10 ⁻³ to 760 Torr)	
Accuracy	% of reading	Units
	±10%	1.3 x 10 ⁻³ to 1.3 mbar (1 milliTorr to 1 Torr)
	±15%	1.3 to 13.3 mbar (1 to 10 Torr)
	±50%	13.3 to 213 mbar (10 to 160 Torr)
	±25%	213 to 1000 mbar (160 Torr to 760 Torr)
Vacuum fitting	½ inch NPT-M	
Interface cable length	10 ft.	
Sensor	See below	
Display	0.38 inch high 6 digit red LED	
Dimensions	1.7 inch high, 3.52 inch wide, 5.35 inch deep	
Analog output	0-5 VDC	
Supply voltage	100-240 VAC, 50/60 Hz	
Standards	CE, ROHS compliant	
Set point controls	7 A, 250 V	
Communication interface	RS-232	
Mounting	½ DIN rack mount	

Ordering Information

Description	Part Number
RGC-150 Rough Gauge Controller	RGC150
RGC-150 Rough Gauge Controller with Ethernet and Software	RGC150E
RGC-150, 1.33" CFF TC, Rough Vac Controller	RGC150CF
RGC-150, KF16 536TC, Rough Vac Controller	RGC150KF16
RGC-150, KF25 536TC, Rough Vac Controller	RGC150KF25
RGC-150, 1.33" CFF TC, Rough Vac Controller, Ethernet	RGC150ECF
RGC-150, KF16 536TC, Rough Vac Controller, Ethernet	RGC150EKF16
RGC-150, KF25 536TC, Rough Vac Controller, Ethernet	RGC150EKF25

Accessories

Replacement sensors	
½ inch NPT-M	F0472303
KF16	L6141308
KF25	L6141309
1.33 in CFF	L6141305

NOTE All units include set points, RS232 and analog output.

GAUGE CABLES

NOTE All cables are available in 5 foot increments.

Ordering Information

Description	Length (in feet)	Part Number	Shipping Weight kg (lbs)
XGS-600 I/O, with flying leads	10	R32493010	2.0 (1.0)
	25	R32493025	2.0 (1.0)
	50	R32493050	3.0 (1.5)
Thermocouple Cables (<i>XGS-600 and senTorr only</i>) For use with one 531 or 536 gauge tubes	10	L91313010	2.0 (1.0)
	25	L91313025	2.0 (1.0)
	50	L91313050	3.0 (1.5)
	75	L91313075	
	100	L91313100	
ConvecTorr Cables (<i>XGS-600, Multi-Gauge, senTorr and PanelVac ConvecTorr</i>) Standard non-bakeable	10	L91223010	2.0 (1.0)
	25	L91223025	2.0 (1.0)
	50	L91223050	3.0 (1.5)
	100	L91223100	
Thermocouple Cables (<i>Multi-Gauge only</i>) Dual (for use with two gauges) Dual (for use with two gauges) Quad (for use with four gauges) Quad (for use with four gauges)	10	L64752010	2.0 (1.0)
	25	L64752025	2.0 (1.0)
	10	L64754010	2.0 (1.0)
	25	L64754025	2.0 (1.0)
Glass BA Gauge Cables Standard non-bakeable	10	R32443010	2.0 (1.0)
	25	R32443025	2.0 (1.0)
	100	R32443050	2.0 (1.0)
MBA2-200 Gauge Cables	10	X320360006	2.0 (1.0)
	25	X320360007	2.0 (1.0)
	50	X320360008	3.0 (1.5)
	65	X320360009	3.0 (1.5)
	75	X320360010	3.0 (1.5)
UHV-24/UHV-24p Standard Standard non-bakeable	10	R32453010	2.0 (1.0)
	25	R32453025	2.0 (1.0)
	50	R32453050	3.0 (1.5)
UHV-24/UHV-24p PTFE (for UHV) bakeable to 250 °C	10	R32463010	2.0 (1.0)
	25	R32463025	2.0 (1.0)
	50	R32463050	3.0 (1.5)
Ion Gauge Extension Cables (<i>XGS-600</i>)	65	R3247065	
	90	R3247090	

VACUUM MEASUREMENT

Ordering Information

Description	Length (in feet)	Part Number	Shipping Weight kg (lbs)	
IMG-100 Cables (<i>XGS-600</i>) Standard non-bakeable may be used with IMG-300	10	R03113010	2.0 (1.0)	
	25	R03113025	2.0 (1.0)	
	50	R03113080	3.0 (1.5)	
	75	R03113075		
	100	R03113100		
IMG-300 Cables Inverted Magnetron Gauge (<i>UHV</i>) Bakeable to 250 °C	10	R03413010	2.0 (1.0)	
	25	R03413025	2.0 (1.0)	
	65	R03413065		
	100	R03413100		
FRG-700 Cables Gauge to FRG Controller Gauge to FRG Controller Gauge to AG Turbo Controller	3 m	AGCCBL103		
	5 m	AGCCBL105		
	3 m	9699960		
	5 m	9699961		
XGS-600 Analog Board Cables		Part Number		
Cable Length	3 ft	10 ft	25 ft	50 ft
FRG-700/PVG/PCG Analog Input Board	R35893003	R35893010	R35893025	R35893050
CDG Analog Input Board	R35903003	R35903010	R35903025	R35903050
FRG720/730 Analog Input Board	R35913003	R35913010	R35913025	R35913050

Vacuum Gauge Technical Notes

Historical Notes

Early interest in pressure measurement was stimulated in the 17th century by engineers who were concerned about the inability of suction pumps to remove water from mines. The pumps were limited to about 30 feet. For example, the Duke of Tuscany (Italy) commissioned Galileo to investigate the problem.

Galileo, among others, devised a number of experiments to investigate the properties of air. Among these experiments were pistons for measuring the “force of vacuum” and a water barometer that stood about 34 feet tall.

After Galileo’s death in 1642, the work was carried on by his associate, Evangelista Torricelli. Torricelli invented the mercury barometer (Figure 1) and he concluded that atmospheric air forced water up to a height of 33.6 feet.

Figure 1 - Mercury Barometer

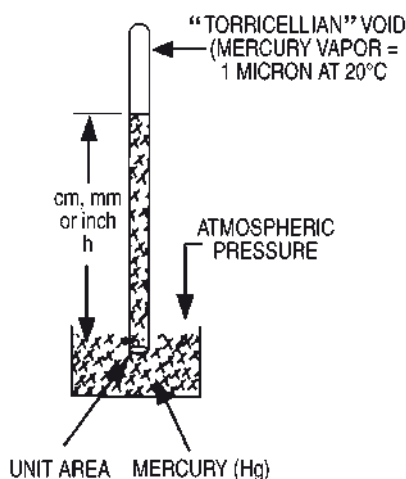

Figure 1 Notes

- Air has weight...mass
 - 2 lbs per cubic yard, or
 - 1.293 grams per liter
- Pressure = force per unit area
- The Barometer – At “standard conditions”, the height of the Hg column above the surface of the Hg in the dish will be 760 mm or 29.9 in. The density of mercury is 0.49 lbs per cubic inch and, if the column is 29.9 in. high, it would then exert a force per unit area of $0.49 \times 29.9 = 14.7$ pounds/in².

The weight of the atmosphere exerts a force of 14.7 pounds per square inch on the surface of the Hg in the dish. The height of the mercury column is therefore a direct measure of the pressure and the unit of pressure is 1/760 of an atmosphere, which is called a Torr. The international pressure unit is Pascal, equal to one Newton per meter square.

In 1644, the French mathematician, Blaise Pascal, sent a group of mountaineers up into the Alps with a barometer and proved that air pressure decreased with altitude. The average height of the mercury column at sea level is 760 mm, and this

is defined as a standard atmosphere.

This also is 1.01×10^5 Pascals or 1.01×10^5 dynes cm². The 1/760 of this value is called a Torr in honor of Torricelli.

An extension of the mercury barometer was the mercury U-tube manometer (Figure 2). Varying atmospheric pressures causes the mercury level to rise and fall in the “Torricellian Void.” Likewise, if the pressure at the other end of the tube is artificially reduced by a vacuum pump, the mercury in the tube falls drastically.

With both the barometer and the manometer, it is the difference in heights of the mercury levels that indicates the pressure, that is, the force (weight of Hg) per unit area that the air pressure will support. As the pressure on the system side is reduced, the height of the columns on either side of the U-tube approaches the same, and any difference becomes very difficult to measure (Figure 2).

Figure 2 - U-Tube Manometer

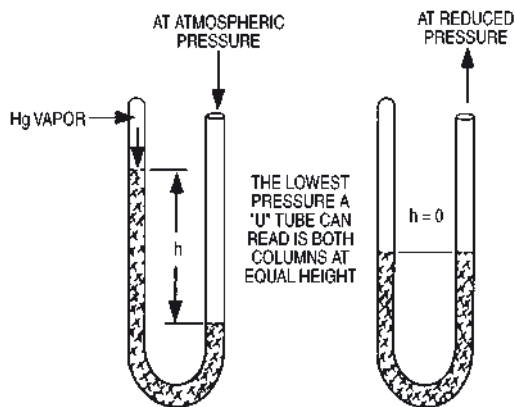

Many schemes were tried to magnify the very small differences that occurred at very low pressures, but the only one that really extended the range of the manometer was invented by H. McLeod in 1872. This gauge is an application of Boyle’s Law and is still in use today as a standard for calibrating secondary gauges (Figure 3).

Figure 3 - McLeod Gauge

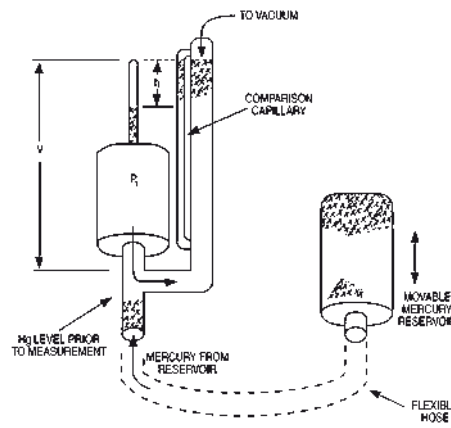

VACUUM MEASUREMENT

Application of Boyle's Law

$$\begin{aligned}
 P_2 & & V_2 \\
 (P_1 + h) bh & = & P_1 V_1 \\
 P_1 bh + bh^2 & = & P_1 V_1 \\
 bh^2 & = & P_1 V_1 - P_1 bh \\
 bh^2 & = & P_1 (V_1 - bh) \\
 P_1 & = & \frac{bh^2}{V_1 - bh}
 \end{aligned}$$

V_1 = Total volume, capillary plus bulb (cm^3)

P_1 = Pressure in system

b = Volum of capillary (in cubic cm)
mm length

h = Difference in height of mercury columns

$V_2 = bh$ (cm^3) volume in capillary

Figure 4 - Pressure Ranges of Various Vacuum Gauges

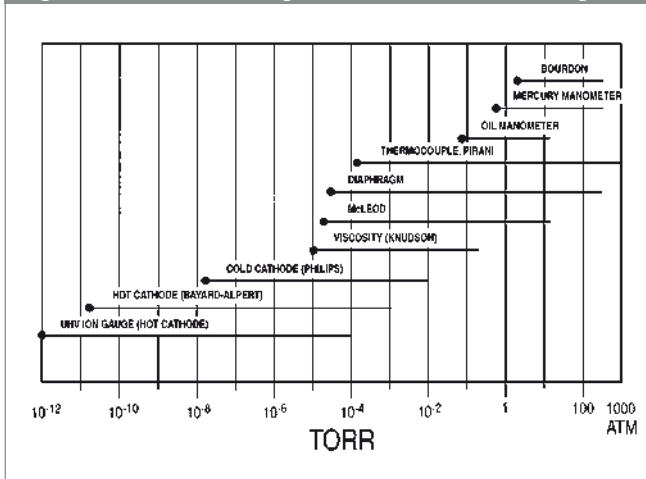

Applications

The vacuum gauges in use today mainly fall into three categories: mechanical, manometric, and electronic. Which gauge is used in a particular application generally depends on the pressure range it is intended to measure. Figure 4 shows useful pressure ranges of some typical gauges.

High pressures, such as those found in the rough pumping of a vacuum system, are generally measured with a thermocouple gauge. This instrument measures heat transfer rate from a heated wire. As gas is removed from the system, less heat is removed. The changes in temperature are measured by a thermocouple junction and its output is displayed as changes in pressure. The most useful pressure range for this gauge is from 5 Torr to 5 microns.

At lower pressures – from 1×10^{-2} Torr to 1×10^{-7} Torr – found in many industrial applications, the cold cathode gauge is very useful. This instrument is basically a gaseous electric discharge cell which operates on the same principle as a diode-type ion pump. It is a rugged gauge that does not use a hot filament.

The most commonly used measurement device for high vacuum is the hot filament ionization gauge. This type of gauge can be designed to measure pressures as high as 5×10^{-1} Torr, and as low as 5×10^{-12} Torr. Since it is found in many industrial and scientific applications, it will be treated here in more detail.

Basic Performance Factors of Ionization Gauges

- 1. Reproducibility.** A gauge must be able to give reproducible readings for identical physical situations. Drift due to electric or geometric instabilities can have adverse effects on the measurement process.
- 2. Accuracy.** Gauges can be calibrated but, in general, their accuracy is limited to about $\pm 20\%$.
- 3. Sensitivity.** In the ion gauge, the positive ions that impact the collector (and pick up electrons from ground) account for the positive ion current (I^+).

The electrons emitted from the filament (I^-) produce the required ionization. The fundamental relationship is:

$$I^+ = (I^-)^{PK} \quad (1)$$

Where: (P) is the number of molecules present (Pressure)

And: (K) is the gauge constant which depends on the geometry of the device and the electrical parameters employed (K) is also referred to as the sensitivity (S), and:

$$S = \frac{I^+}{P \cdot I^-}$$

Where: Both (I^+) and (I^-) are measured in amperes and (P) is in Torr.

$$\text{Hence:} \quad S = \frac{(I^+) \text{ Amps}}{(I^-) \text{ Amps Torr}} = (\text{a number}) \text{ torr}$$

For instance, the sensitivity of the Agilent UHV-24 nude gauge is 25 per Torr.

AGILENT TECHNICAL NOTES

Operation of Ionization Gauges

Table 1 - Conversion Table						
	Pascal (N/m ²) (Pa)	Torr	Standard Atmosphere (atm)	Millibar (mbar)	Dyne per Square Centimeter (dyne/cm ²)	
1 Newton per square meter (N/m ²) = Pascal	= 1	7.5 x 10 ⁻³	9.87 x 10 ⁻⁶	10 ⁻²	10	
1 Torr = 1 mm Hg	= 133	1	1.32 x 10 ⁻³	1.33	1,330	
1 standard atmosphere (atm)	= 101,000	760	1	1,010	1,010,000	
1 millibar (mbar)	= 100	0.75	9.87 x 10 ⁻⁶	1	1,000	
1 dyne/square centimeter (dyne/cm ²)	= 10 ⁻¹	7.5 x 10 ⁻⁴	9.87 x 10 ⁻⁷	x 10 ⁻³	1	

When an ionization gauge is used to measure pressure, two physically observable parameters are of interest; namely, emission current and ion current. These two currents must be observed simultaneously, and the pressure can be calculated by the following rule:

$$P = \frac{(I^+) 1}{(I^-) S}$$

- I⁺ = Observed ion current
- I⁻ = Observed emission current
- S = Gauge sensitivity (constant for any particular gauge)

Although the McLeod gauge uses mercury in a way different from the manometer, it still expresses pressure in terms of the height of a mercury column. At the pressures attained by modern vacuum systems, gauges that depend on the mechanical effects of pressure are ineffective. So, other means had to be found that could take advantage of other properties of atoms and molecules, such as heat conductivity or the ability to be ionized.

There are many ways to express pressure and some of the more common units are listed in Table 1.

The gauge sensitivity, S, is a function of the design and construction of the gauge. For the Agilent 563 Bayard-Alpert gauge, S has a nominal value of 10 Torr. For the Agilent 507 Triode gauge, S has a nominal value of 17 Torr.

One could use an instrument that measured both the I⁺ and I⁻ currents with a high degree of accuracy. However, the absolute values of I⁺ and I⁻ are unimportant in determining P; only their ratio must be measured. Therefore, entirely equivalent results can be obtained with an instrument which measures I⁺ as a fraction of I⁻ (a ratiometric instrument).

Table 2 - Pressure and Flow Unit	
Pressures	
Standard atm	= 1.01325 x 10 ⁶ Dynes cm ⁻² = 760 mm Hg (at 0 °C) = 29.9213 in. of Hg (at 32 °F)
Bar	= 1 x 10 ⁶ Dynes cm ⁻² 75.0062 cm Hg (at 0 °C) 0.986 atm
Torr	= 1333 Dynes cm ⁻² = 1 mm Hg (at 0 °C) = (760) ⁻¹ Standard atm
Micron	= (length) 1000 Angstroms (1A = 10 ⁻¹⁰ meter) = (pressure) 1.33 Dyne cm ⁻² = (pressure) 1 x 10 ⁻³ Torr
Barye	= 1 Dyne cm ⁻² = 9.869 x 10 ⁻⁷ atm = 1 x 10 ⁻⁶ bar
Dyne	= Force necessary to give a one-gram mass an acceleration of one cm/sec/sec
Flows	
Cubic Foot	= 28.3 liters = 2.83 x 10 ⁴ cm ³
CFM	= 28.3 liters min ⁻¹ = 0.47 liter sec ⁻¹
Liter sec ⁻¹	= 2.12 cfm = 3.53 x 10 ⁻² cubic feet sec ⁻¹

VACUUM MEASUREMENT

It is convenient to maintain a constant emission current at a preselected value rather than to observe it for each measurement of pressure. Thus, in some gauge controls, the emission current is regulated at a nominal value of 9 ma (Bayard-Alpert) or 6 ma (triode). This value of emission leads to ion currents equal to 0.1 amp/Torr. During the calibration procedure, emission current is sensed by the electrometer amplifier and displayed on the panel meter. When the ion current is measured, the same amplifier and meter are used. Hence, the meter deflection observed during ion current measurement is automatically interpreted as a fraction of emission current, providing a true ratiometric measurement, even though the absolute value of emission current may be 20% different from nominal.

In conventional gauge controls, emission current is measured by the panel meter with suitable precision resistor shunts. The ion current is then amplified by an electrometer and displayed on the meter. Overall accuracy of this kind of system depends on the individual accuracies of the shunt resistors, the meter movement, and the electrometer gain. Since these items all function independently, the errors can add up.

However, in the Agilent ionization gauge controls, the electrometer and meter are always used together, whether measuring emission or ion currents. Thus, some of the errors are cancelled in the calibration process. As a result, the accuracy of the Agilent controls is not critically dependent on

the tolerances of a large number of components, and long-term accuracy and repeatability are assured.

Some additional conversion factors for pressure and flow units are shown in Table 2.

Cold Cathode Gauges

The cold cathode gauge is an often overlooked, cost-effective gauge for ion implanters and other high-vacuum applications. A cold cathode gauge has no filament, is not subject to burnout and has a significantly longer life and lower annual replacement cost than a hot cathode Bayard-Alpert gauge. A cold-cathode gauge can be replaced at predictable intervals, whereas a hot cathode gauge must be replaced whenever a burnout occurs. In addition, the annual cost of replacement is less. A modern inverted magnetron cold cathode gauge is stable and can operate over a wide pressure range from 10 mTorr down to ultra-high vacuum. Repeatability is better than 98%. Cold cathode gauges have a reputation as 'slow starters,' since they must rely on an ionization source such as a cosmic ray to initiate a discharge. The lower the pressure, the less likely an ionizing collision and the longer the start delay. At 1 mTorr or higher, there is no delay; but at 10^{-8} Torr, starting can take up to 3 hours. The traditional solution is to start the gauge in the mTorr range, but often this is not practical. A relatively new technique uses ultraviolet induced photoemission to generate an ionizing electron to start the gauge. At 10^{-6} Torr the start time is 4-5 seconds.



AGILENT VACUUM VALVES

- 2-3 Agilent Vacuum Valve Solutions
- 4-17 Agilent High Performance Valves
- 18-21 Stainless Steel Tube Valves
- 22-23 Electromagnetic Block Valves
- 24 Variable Leak Valves



Agilent Technologies

AGILENT VACUUM VALVE SOLUTIONS

Agilent offers a range of vacuum valves that are engineered for reliability, performance, and value. These valves also optimize conductance, operate in a wide variety of applications, and employ a minimum of moving parts. This reduces wear and particle generation which contributes to their performance and reliability. Agilent valves are manufactured using the highest quality vacuum materials and provide a choice of actuation, and a variety of mounting flanges.

Agilent High Performance Valves

We are pleased to add to our offering valve products manufactured to the highest international standards. The Series 26 Aluminum Block Valves, Series 12 Aluminum Gate Valves, and Series 54 UHV All-Metal Valves are the proven workhorses in their respective application segments. These are easily ordered with any of Agilent's vacuum pumps or other components.

Agilent High Performance Valves

Agilent Vacuum Valves



Series 26 Aluminum Block Valves
Multi-purpose, high cycle life valves; position indication.



Stainless Steel Tube Valves
Provide maximum conductance, low outgassing, and easy installation.



Series 12 Aluminum Gate Valves
Robust, compact, high conductance means of isolating a high vacuum pump.



Electromagnetic Block Valves
Rapid spring closure, service-free; eliminate the need for compressed air.



Series 54 UHV All-Metal Valves
Extreme High Vacuum (XHV) compatible with dynamic all-metal sealing system.



Variable Leak Valve
Unique device provides extremely precise control of gas flow to vacuum system.



VACUUM VALVES

Common Applications

- **Rough Vacuum**
 - Freeze drying
 - Food processing
 - Metal ore refining
 - Steam plant condensers
 - Vacuum distillation
- **Medium Vacuum**
 - Decorative coatings
 - Functional coatings
 - Chemical processes
 - Electron microscopes
 - Microscopy sample processing
- **High/Ultrahigh Vacuum**
 - Physics research
 - Optics
 - High energy
 - Semiconductor manufacturing
 - Electron tube manufacturing
 - Surface analysis (Auger Spectroscopy)
 - Molecular beam epitaxy
 - Outer space simulation



Vacuum Range	Valve Type	Housing Material	Size Range	Feed-through	Flange Options	Actuation	Page
Primary/Medium to High Vacuum							
Atm - 10 ⁻⁶ Torr	Block, Right Angle	Aluminum	0.75 in. to 1.0 in.	Shaft	ISO-KF	Electromagnetic	22-23
Atm - 10 ⁻⁹ Torr	Block, Right Angle	<i>Series 26</i> Aluminum	0.75 in. to 1.5 in.	Bellows	ISO-KF	Manual/Air	4-9
Atm - 10 ⁻⁹ Torr	Block, In-Line	<i>Series 26</i> Aluminum	0.75 in. to 1.0 in.	Bellows	ISO-KF	Manual/Air	4-9
Atm - 10 ⁻⁹ Torr	Tube, Right Angle	Stainless Steel	0.63 in. to 1.5 in.	Bellows	CF, ISO-KF	Manual/Air	18-21
Atm - 10 ⁻⁹ Torr	Tube, In-Line	Stainless Steel	0.63 in. to 1.5 in.	Bellows	CF, ISO-KF	Manual/Air	18-21
Atm - 10 ⁻⁹ Torr	Gate	<i>Series 12</i> Aluminum	2.5 in. to 10 in.	Shaft	ISO, ASA	Manual/Air	10-14
Ultra High Vacuum							
Atm - 10 ⁻¹¹ Torr	UHV, All-Metal Angle	<i>Series 54</i> Stainless Steel	0.75 in. to 1.5 in.	Bellows	CF	Manual	15-17
Special Purpose							
Atm - 10 ⁻¹¹ Torr	Variable Leak	Stainless Steel		Bellows	CF	Manual	24

AGILENT HIGH PERFORMANCE VALVES

▶ Agilent Aluminum Block Valves - Series 26



Thank you for choosing Agilent Valves. These valves are designed with the highest international vacuum standards and manufactured with uncompromising quality. We are confident that Agilent Valves will meet your most demanding vacuum control needs.

The valves are available in manually-operated and pneumatically-operated versions. The pneumatic valve is also available with a position indicator.

The position indicator delivers an electrical output signal when the valve cycles, and is user-set in either the normally-open or normally-closed position.

Technical Specifications

Cycles until first service	
with manual actuator	10 000
with closing spring	3 million
Maximum temperature	
Valve body	≤ 150 °C
Manual and pneumatic actuator	≤ 120 °C
Solenoid valve, position indicator	≤ 80 °C
Material	
Valve body aluminum	EN AW-6060 (3.3206)
Plate	AISI 316L (1.4404, 1.4435)
Bellows	AISI 316L (1.4404, 1.4435), AISI 316 Ti (1.4571)
Seal: bonnet, plate	FKM (Viton)
Mounting orientation	any
Solenoid valve	24 V DC, 115 V AC, 220 V AC; 2.5 W
Position indicator: contact rating	
Voltage	5–50 V AC / DC
Current	5–100 mA
Valve position indication	visual (mechanical)
Leak rate: valve body, valve seat	< 1 · 10 ⁻⁹ mbar ls ⁻¹
Pressure range, series 26 (bellows)	1 · 10 ⁻⁸ mbar to 5 bar (abs)
Differential pressure on the plate	
In opening direction	≤ 2.0 bar
In closing direction	≤ 5.0 bar
Differential pressure at opening	≤ 1 bar

VACUUM VALVES

Features

- Body material: aluminum
- Angle and inline version
- Bellows
- Resistant against differential pressure
- Long lifetime

Aluminum Block Valves Functional Principle

NW 16–40 with pneumatic actuator NC

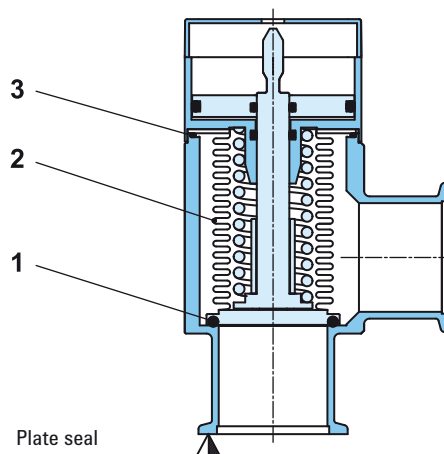

- 1 Plate seal
- 2 Bellows
- 3 Bonnet seal
- ▼ Valve seat side

Angle valves

NW (nominal I. D.) mm (in.)	Conductance (molecular flow) ls ⁻¹	Valve with manual actuator		Valve with pneumatic actuator, single acting with closing spring (NC)				
		Turns per stroke n	Weight Aluminum body kg (lbs)	Compressed air min.–max. overpressure bar (psi)	Volume of pneumatic actuator l ft ³		Closing time s	Weight Aluminum body kg (lbs)
16 (5/8)	5	3.6	0.20 (0.44)	4–8 (58–116)	0.004	0.0001	0.10	0.28 (0.62)
25 (1)	14	3.8	0.27 (0.60)	4–8 (58–116)	0.011	0.0004	0.20	0.41 (0.90)
40 (1 1/2)	45	4.5	0.60 (1.32)	4–8 (58–116)	0.035	0.0012	0.55	0.97 (2.14)

Inline valves

NW (nominal I. D.) mm (in.)	Conductance (molecular flow) ls ⁻¹	Valve with manual actuator		Valve with pneumatic actuator, single acting with closing spring (NC)				
		Turns per stroke n	Weight Aluminum body kg (lbs)	Compressed air min.–max. overpressure bar (psi)	Volume of pneumatic actuator l ft ³		Closing time s	Weight Aluminum body kg (lbs)
16 (5/8)	5	3.6	0.28 (0.62)	4–8 (58–116)	0.004	0.0001	0.10	0.50 (1.10)
25 (1)	14	3.8	0.42 (0.93)	4–8 (58–116)	0.011	0.0004	0.20	0.60 (1.32)
40 (1 1/2)	45	4.5	1.00 (2.20)	4–8 (58–116)	0.035	0.0012	0.55	1.40 (3.09)

AGILENT HIGH PERFORMANCE VALVES

Dimensions

Angle valve with manual actuator

NW 16–40 (5/8"–1 1/2") ISO-KF

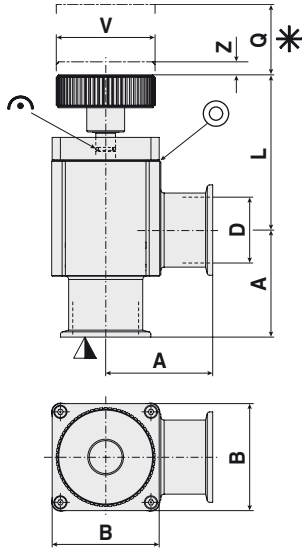

Models	NW 16 (5/8)	NW 25 (1)	NW 40 (1 1/2)
A	40 (1.57)	50 (1.97)	65 (2.56)
B	40 (1.57)	48 (1.89)	65 (2.56)
D	16 (0.63)	25 (0.98)	40 (1.57)
L	64.90 (2.56)	60.90 (2.40)	94.30 (3.71)
Q	46 (1.81)	44 (1.73)	73.50 (2.89)
V	40 (1.57)	40 (1.57)	60 (2.36)
Z*	3.60 (0.14)	4.70 (0.19)	7.90 (0.31)

* Gate stroke is longer due to transmission

- ▼ Valve seat side
- * Required for dismantling
- ↻ Mechanical position indication
- ⊙ Leak detection hole

Dimensions: millimeters (inches)

Inline valve with manual actuator

NW 16–40 (5/8"–1 1/2") ISO-KF

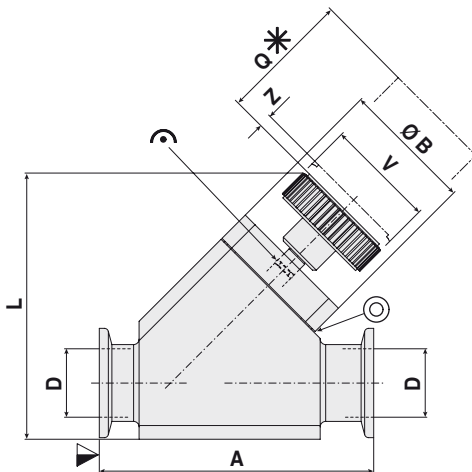

Models	NW 16 (5/8)	NW 25 (1)	NW 40 (1 1/2)
A	80 (3.15)	100 (3.94)	130 (5.12)
B	40 (1.57)	48 (1.89)	65 (2.56)
D	16 (0.63)	25 (0.98)	40 (1.57)
L	90.60 (3.57)	97 (3.82)	143.50 (5.65)
Q	46 (1.81)	44 (1.73)	73.50 (2.89)
V	40 (1.57)	40 (1.57)	60 (2.36)
Z	3.60 (0.14)	4.70 (0.19)	7.90 (0.31)

Dimensions: millimeters (inches)

VACUUM VALVES

Dimensions

Angle valve with pneumatic actuator, single acting with closing spring

NW 16–40 ($\frac{5}{8}$ "–1 $\frac{1}{2}$ " ISO-KF)

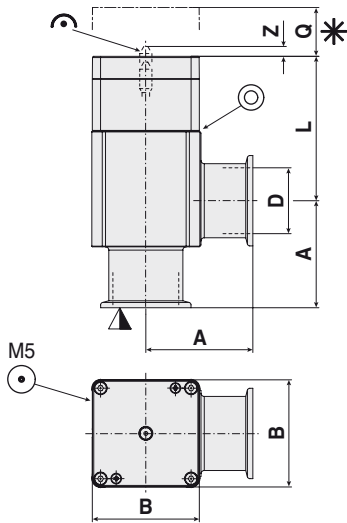

Models	NW 16	NW 25	NW 40
	($\frac{5}{8}$)	(1)	(1 $\frac{1}{2}$)
A	40	50	65
	(1.57)	(1.97)	(2.56)
B	40	48	65
	(1.57)	(1.89)	(2.56)
D	16	25	40
	(0.63)	(0.98)	(1.57)
L (with closing spring)	65.20	60.60	87.70
	(2.57)	(2.39)	(3.45)
Q	46	44	73.50
	(1.81)	(1.73)	(2.89)
Z	2	4	9.50
	(0.08)	(0.16)	(0.37)

- ▼ Valve seat side
- * Required for dismantling
- ⊙ Compressed air connection
- ⌚ Mechanical position indication
- ⊙ Leak detection hole

Dimensions: millimeters (inches)

Inline valve with pneumatic actuator, single acting with closing spring

NW 16–40 ($\frac{5}{8}$ "–1 $\frac{1}{2}$ " ISO-KF)

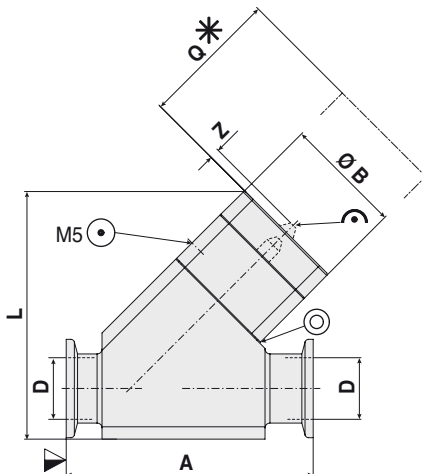

Models	NW 16	NW 25	NW 40
	($\frac{5}{8}$)	(1)	(1 $\frac{1}{2}$)
A	80	100	130
	(3.15)	(3.94)	(5.12)
B	40	48	65
	(1.57)	(1.89)	(2.56)
D	16	25	40
	(0.63)	(0.98)	(1.57)
L (with closing spring)	91.50	100.30	140.90
	(3.60)	(3.95)	(5.55)
Q	46	44	73.50
	(1.81)	(1.73)	(2.89)
Z	2	4	9.50
	(0.08)	(0.16)	(0.37)

Dimensions: millimeters (inches)

AGILENT HIGH PERFORMANCE VALVES

Solenoid valve

Solenoid valve

NW 16–40 (5/8"–1 1/2")

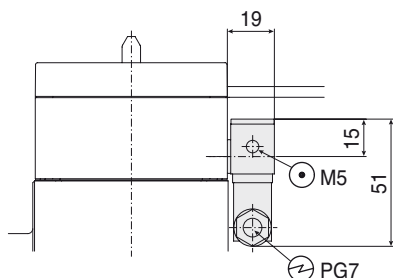

Position indicator

Position indicator

NW 16–40 (5/8"–1 1/2")

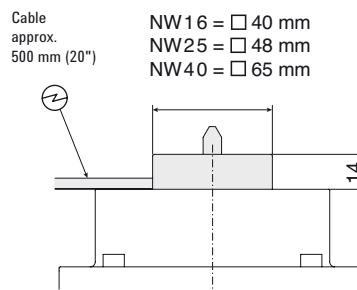

One closing contact each for the open and closed valve positions

Ordering Information

Description: Aluminum Right Angle Block Valves Series 26	Part Number
Valve, Block, Aluminum, Right Angle, Hand-operated, NW16	X3202-60031
Valve, Block, Aluminum, Right Angle, Hand-operated, NW25	X3202-60032
Valve, Block, Aluminum, Right Angle, Hand-operated, NW40	X3202-60033
Valve, Block, Aluminum, Right Angle, Air-operated, NW16, without Solenoid	X3202-60034
Valve, Block, Aluminum, Right Angle, Air-operated, NW25, without Solenoid	X3202-60035
Valve, Block, Aluminum, Right Angle, Air-operated, NW40, without Solenoid	X3202-60036
Valve, Block, Aluminum, Right Angle, Air-operated, NW16, 115VAC	X3202-60037
Valve, Block, Aluminum, Right Angle, Air-operated, NW25, 115VAC	X3202-60038
Valve, Block, Aluminum, Right Angle, Air-operated, NW40, 115VAC	X3202-60039
Valve, Block, Aluminum, Right Angle, Air-operated, NW16, 220VAC	X3202-60040
Valve, Block, Aluminum, Right Angle, Air-operated, NW25, 220VAC	X3202-60041
Valve, Block, Aluminum, Right Angle, Air-operated, NW40, 220VAC	X3202-60042
Valve, Block, Aluminum, Right Angle, Air-operated, NW16, 24VDC	X3202-60043
Valve, Block, Aluminum, Right Angle, Air-operated, NW25, 24VDC	X3202-60044
Valve, Block, Aluminum, Right Angle, Air-operated, NW40, 24VDC	X3202-60045
Valve, Block, Aluminum, Right Angle, Air-operated, Position Indicator, NW16, without Solenoid	X3202-60051
Valve, Block, Aluminum, Right Angle, Air-operated, Position Indicator, NW25, without Solenoid	X3202-60052
Valve, Block, Aluminum, Right Angle, Air-operated, Position Indicator, NW40, without Solenoid	X3202-60053
Valve, Block, Aluminum, Right Angle, Air-operated, Position Indicator, NW16, 115VAC	X3202-60054
Valve, Block, Aluminum, Right Angle, Air-operated, Position Indicator, NW25, 115VAC	X3202-60055
Valve, Block, Aluminum, Right Angle, Air-operated, Position Indicator, NW40, 115VAC	X3202-60056
Valve, Block, Aluminum, Right Angle, Air-operated, Position Indicator, NW16, 220VAC	X3202-60057
Valve, Block, Aluminum, Right Angle, Air-operated, Position Indicator, NW25, 220VAC	X3202-60058
Valve, Block, Aluminum, Right Angle, Air-operated, Position Indicator, NW40, 220VAC	X3202-60059
Valve, Block, Aluminum, Right Angle, Air-operated, Position Indicator, NW16, 24VDC	X3202-60060
Valve, Block, Aluminum, Right Angle, Air-operated, Position Indicator, NW25, 24VDC	X3202-60061
Valve, Block, Aluminum, Right Angle, Air-operated, Position Indicator, NW40, 24VDC	X3202-60062

VACUUM VALVES

Ordering Information

Description: Aluminum Inline Block Valves Series 26	Part Number
Valve, Block, Aluminum, In-line, Hand-operated, NW16	X3202-60063
Valve, Block, Aluminum, In-line, Hand-operated, NW25	X3202-60064
Valve, Block, Aluminum, In-line, Hand-operated, NW40	X3202-60065
Valve, Block, Aluminum, In-line, Air-operated, NW16, without Solenoid	X3202-60066
Valve, Block, Aluminum, In-line, Air-operated, NW25, without Solenoid	X3202-60067
Valve, Block, Aluminum, In-line, Air-operated, NW40, without Solenoid	X3202-60068
Valve, Block, Aluminum, In-line, Air-operated, NW16, 115VAC	X3202-60069
Valve, Block, Aluminum, In-line, Air-operated, NW25, 115VAC	X3202-60070
Valve, Block, Aluminum, In-line, Air-operated, NW40, 115VAC	X3202-60071
Valve, Block, Aluminum, In-line, Air-operated, NW16, 220VAC	X3202-60072
Valve, Block, Aluminum, In-line, Air-operated, NW25, 220VAC	X3202-60073
Valve, Block, Aluminum, In-line, Air-operated, NW40, 220VAC	X3202-60074
Valve, Block, Aluminum, In-line, Air-operated, NW16, 24VDC	X3202-60075
Valve, Block, Aluminum, In-line, Air-operated, NW25, 24VDC	X3202-60076
Valve, Block, Aluminum, In-line, Air-operated, NW40, 24VDC	X3202-60077
Valve, Block, Aluminum, In-line, Air-operated, Position Indicator, NW16, without Solenoid	X3202-60078
Valve, Block, Aluminum, In-line, Air-operated, Position Indicator, NW25, without Solenoid	X3202-60079
Valve, Block, Aluminum, In-line, Air-operated, Position Indicator, NW40, without Solenoid	X3202-60080
Valve, Block, Aluminum, In-line, Air-operated, Position Indicator, NW16, 115VAC	X3202-60081
Valve, Block, Aluminum, In-line, Air-operated, Position Indicator, NW25, 115VAC	X3202-60082
Valve, Block, Aluminum, In-line, Air-operated, Position Indicator, NW40, 115VAC	X3202-60083
Valve, Block, Aluminum, In-line, Air-operated, Position Indicator, NW16, 220VAC	X3202-60084
Valve, Block, Aluminum, In-line, Air-operated, Position Indicator, NW25, 220VAC	X3202-60085
Valve, Block, Aluminum, In-line, Air-operated, Position Indicator, NW40, 220VAC	X3202-60086
Valve, Block, Aluminum, In-line, Air-operated, Position Indicator, NW16, 24VDC	X3202-60087
Valve, Block, Aluminum, In-line, Air-operated, Position Indicator, NW25, 24VDC	X3202-60088
Valve, Block, Aluminum, In-line, Air-operated, Position Indicator, NW40, 24VDC	X3202-60089
Spare Parts	Part Number
Seal Kit, Aluminum Block Valve Series 26, NW16	X3202-60103
Seal Kit, Aluminum Block Valve Series 26, NW25	X3202-60104
Seal Kit, Aluminum Block Valve Series 26, NW40	X3202-60105
O-Ring Removal Tool, Aluminum Block Valve Series 26	X3202-60106

▶ Agilent Aluminum Gate Valves - Series 12



Thank you for choosing Agilent Valves. These valves are designed with the highest international vacuum standards and manufactured with uncompromising quality. We are confident that Agilent Valves will meet your most demanding vacuum control needs.

The valves are available in manual, push-rod operation and double acting pneumatic operation. The pneumatic valves are available with solenoid (pilot) valves at 115 VAC, 220 VAC and 24 VDC, and a position indicator. See operator's manual for more information.

Technical Specifications

Leak rate: valve body, valve seat		$< 1 \cdot 10^{-9}$ mbar ls ⁻¹
Pressure range		
ISO 63–160		$1 \cdot 10^{-7}$ mbar to 1.6 bar (abs)
ISO 250		$1 \cdot 10^{-7}$ mbar to 1.2 bar (abs)
Differential pressure on the gate		
ISO 63–160		≤ 1.6 bar
ISO 250		≤ 1.2 bar
Differential pressure at opening		≤ 30 mbar
Cycles until first service		
ISO 63–160		200 000
ISO 250		100 000
Temperature*		
Valve body		≤ 120 °C
Manual and pneumatic actuator		≤ 80 °C
Solenoid valve		≤ 50 °C
Position indicator		≤ 80 °C
Heating and cooling rate		≤ 30 °C h ⁻¹
Material		
Valve body	ISO 63–160	EN AW-5083 (3.3547), -6061 (3.3211)
	ISO 250	EN AC-42100 (3.2371)
Mechanism	ISO 63–160	AISI 304 (1.4301)
	ISO 250	EN AW-6082 (3.2315)
Seal: bonnet, gate		FKM (Viton)
Feedthrough		shaft feedthrough
Mounting orientation		any
Solenoid valve		24 VDC, 115 V, 220 V, 5.4 W
Position indicator: contact rating		
Voltage	≤ 250 VAC	≤ 50 VDC
Current	≤ 2 A	≤ 1.2 A
Valve position indication		visual (mechanical)

* Maximum values: depending on operating conditions and sealing materials

VACUUM VALVES

Features

- Body material: aluminum
- Low cost gate valve
- Split body for easy cleaning
- VATLOCK configuration

Aluminum Gate Valves Functional Principle

Body style ISO 63-250
Gate mechanism ISO 160-250

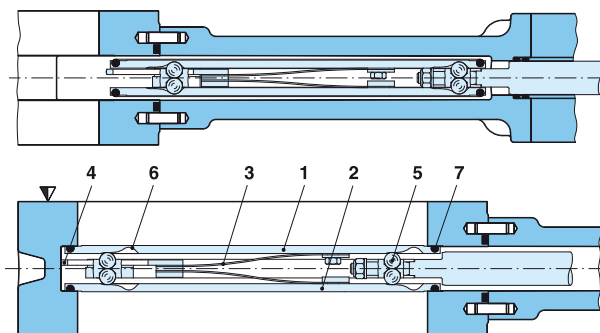

- | | |
|-----------------|-------------------|
| 1 Gate | 5 Ball pairs |
| 2 Counter-plate | 6 Ball detents |
| 3 Leaf springs | 7 Gate seal |
| 4 Spring stop | ▽ Valve seat side |

DN (nominal I. D.) mm (in.)	Standard flanges	Conductance (molecular flow) (depending on A-dimension and flange type) ls ⁻¹	Valve with manual actuator	Valve with pneumatic actuator				
			Weight kg (lbs)	Compressed air min. – max. overpressure bar (psi)	Volume of pneumatic actuator		Closing or opening time s	Weight kg (lbs)
					l	ft ³		
63 (2 ½)	See page 14	550	3.00 (7.00)	4–7 (58–102)	0.16	0.006	1.5	3.00 (7.00)
100 (4)		2000	4.50 (10.00)	4–7 (58–102)	0.22	0.008	2	4.50 (10.00)
160 (6)		6000	9.00 (20.00)	4–7 (58–102)	0.50	0.018	2	9.00 (20.00)
250 (10)		22000	N/A (N/A)	4–7 (58–102)	1.50	0.053	5	25.00 (55.00)

AGILENT HIGH PERFORMANCE VALVES

Main Dimensions

Valve with manual actuator: push rod

DN 63–100 (2½"–4")

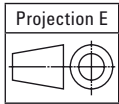
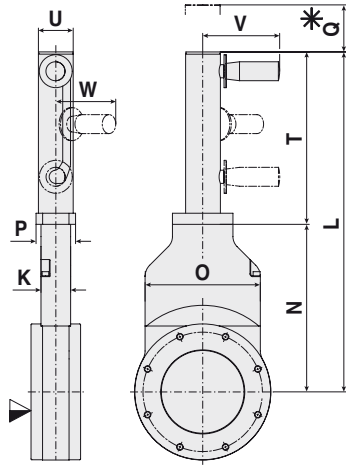

Models	DN 63 (2 ½)	DN 100 (4)	DN 160 (6)
K	36 (1.42)	36 (1.42)	58 (2.28)
L	329.50 (12.97)	413 (16.26)	547 (21.54)
N	155.50 (6.12)	203.50 (8.01)	280 (11.02)
O	100 (3.94)	140 (5.51)	192 (7.56)
P	48 (1.89)	48 (1.89)	70 (2.76)
Q	25 (0.98)	25 (0.98)	60 (2.36)
T	174 (6.85)	209.50 (8.25)	267 (10.51)
U	43 (1.69)	43 (1.69)	65 (2.56)
V	94 (3.70)	94 (3.70)	122 (4.80)
W	75 (2.95)	75 (2.95)	95 (3.74)

Flange dimensions: see page 14

Valve with manual actuator: push rod

DN 160 (6")

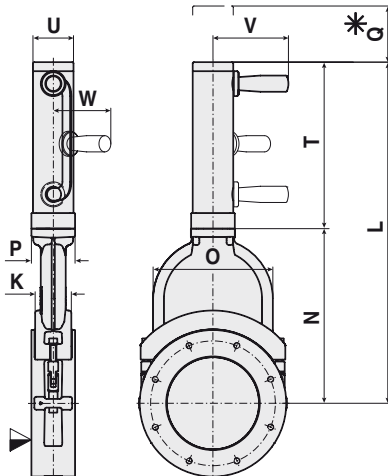

- ▼ Valve seat side
- * Required for dismantling

Dimensions: millimeters (inches)

VACUUM VALVES

Main Dimensions

Valve with pneumatic actuator: double acting

ISO 63–100 (2½"–4")

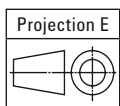
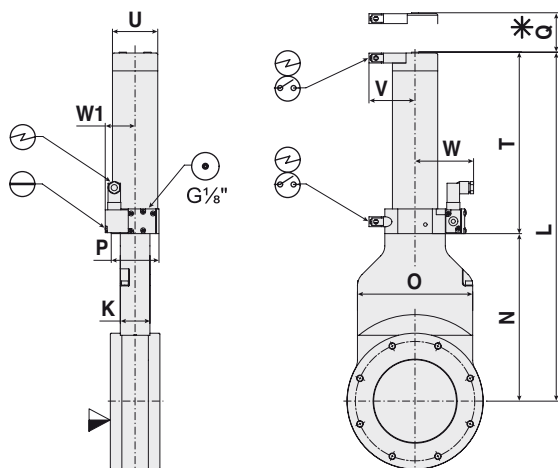

Models	ISO 63 (2 ½)	ISO 100 (4)	ISO 160 (6)	ISO 250 (10)
K	36 (1.42)	36 (1.42)	58 (2.28)	76 (2.99)
L	341.50 (13.45)	425 (16.69)	547 (21.54)	843 (33.19)
N	155.50 (6.12)	203.50 (8.01)	280 (11.02)	453 (17.83)
O	100 (3.94)	140 (5.51)	192 (7.56)	308 (12.13)
P	58 (2.28)	58 (2.28)	70 (2.76)	96 (3.78)
Q	25 (0.98)	25 (0.98)	60 (2.36)	100 (3.94)
T	186 (7.32)	221.50 (8.72)	267 (10.51)	390 (15.35)
U	55 (2.17)	55 (2.17)	65 (2.56)	86 (3.39)
V	56 (2.20)	56 (2.20)	57 (2.24)	67 (2.64)
W	72 (2.83)	72 (2.83)	71.50 (2.82)	84.50 (3.33)
W1	36.50 (1.44)	36.50 (1.44)	–	–

Flange dimensions: see page 14

Valve with pneumatic actuator: double acting

ISO 160 (6")–250 (10")

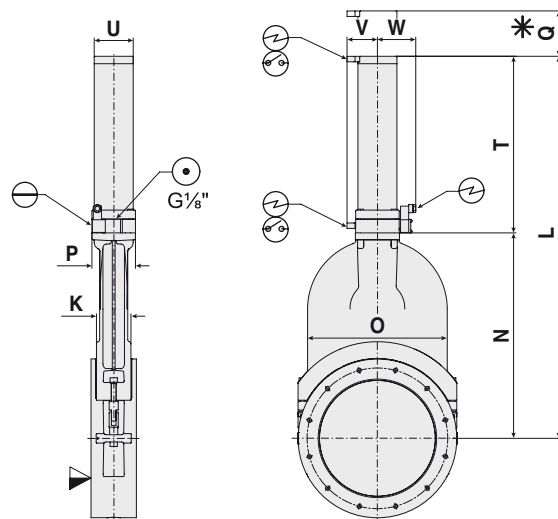

- ▼ Valve seat side
- * Required for dismantling
- ⊙ Compressed air connection
- ⊕ Electrical connection
- ⊖ Position indicator
- ⊖ Emergency operation

Dimensions: millimeters (inches)

AGILENT HIGH PERFORMANCE VALVES

Flange Dimensions

ISO-F

ISO 63–250 (2½"–10")

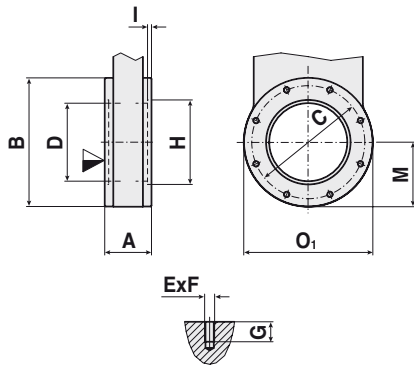

Models	ISO 63	ISO 100	ISO 160	ISO 250
	(2 ½)	(4)	(6)	(10)
A	60 (2.36)	60 (2.36)	70 (2.76)	100 (3.94)
B	130 (5.12)	165 (6.50)	235 (9.25)	350 (13.78)
C	110 (4.33)	145 (5.71)	200 (7.87)	310 (12.20)
D	65 (2.56)	100 (3.94)	150 (5.91)	261 (10.27)
E x F	4 x M8	8 x M8	8 x M10	12 x M10
G	12 (0.47)	12 (0.47)	16 (0.63)	16 (0.63)
H	70 (2.76)	102 (4.02)	153 (6.02)	–
I	3 (0.12)	3 (0.12)	5 (0.20)	–
M	65.50 (2.58)	83 (3.27)	117.50 (4.63)	175 (6.89)
O1	131 (5.16)	166 (6.54)	237 (9.33)	352 (13.86)

Ordering Information

Description Aluminum Gate Valves - Series 12	Part Number
Valve, Gate, Aluminum, 63 ISO, Air-operated, Position Indicator, 115VAC	X3202-60000
Valve, Gate, Aluminum, 63 ISO, Air-operated, Position Indicator, 220VAC	X3202-60001
Valve, Gate, Aluminum, 63 ISO, Air-operated, Position Indicator, 24VDC	X3202-60002
Valve, Gate, Aluminum, 63 ISO, Air-operated, Position Indicator, without Solenoid	X3202-60003
Valve, Gate, Aluminum, 63 ISO, Hand-operated	X3202-60004
Valve, Gate, Aluminum, 100 ISO, Air-operated, Position Indicator, 115VAC	X3202-60010
Valve, Gate, Aluminum, 100 ISO, Air-operated, 220VAC, Position Indicator	X3202-60011
Valve, Gate, Aluminum, 100 ISO, Air-operated, 24VDC, Position Indicator	X3202-60012
Valve, Gate, Aluminum, 100 ISO, Air-operated, Position Indicator, without Solenoid	X3202-60013
Valve, Gate, Aluminum, 100 ISO, Hand-operated	X3202-60014
Valve, Gate, Aluminum, 160 ISO, Air-operated, Position Indicator, 115VAC	X3202-60020
Valve, Gate, Aluminum, 160 ISO, Air-operated, Position Indicator, 220VAC	X3202-60021
Valve, Gate, Aluminum, 160 ISO, Air-operated, Position Indicator, 24VDC	X3202-60022
Valve, Gate, Aluminum, 160 ISO, Air-operated, Position Indicator, without Solenoid	X3202-60025
Valve, Gate, Aluminum, 160 ISO, Hand-operated	X3202-60026
Valve, Gate, Aluminum, 250 ISO, Air-operated, Position Indicator, 115VAC	X3202-60027
Valve, Gate, Aluminum, 250 ISO, Air-operated, Position Indicator, 220VAC	X3202-60028
Valve, Gate, Aluminum, 250 ISO, Air-operated, Position Indicator, 24VDC	X3202-60029
Valve, Gate, Aluminum, 250 ISO, Air-operated, Position Indicator, without Solenoid	X3202-60030
Spare Parts	Part Number
Seal Kit, Aluminum Gate Valve Series 12, ISO 63	X3202-60099
Seal Kit, Aluminum Gate Valve Series 12, ISO 100	X3202-60100
Seal Kit, Aluminum Gate Valve Series 12, ISO 160	X3202-60101
Seal Kit, Aluminum Gate Valve Series 12, ISO 250	X3202-60102

▶ Agilent UHV All Metal Valves - Series 54



Thank you for choosing Agilent's High Performance Valves. These valves are designed with the highest international vacuum standards and manufactured with uncompromising quality. We are confident that you will find these valves meet your most demanding vacuum control needs.

The valves are manually operated with a standard Hex wrench, so no Torque Wrench is required. Thanks to the "hard-on-hard" metal seals, these valves can be operated thousands of times before requiring maintenance.

Technical Specifications

Leak rate: valve body, valve seat	$< 1 \cdot 10^{-10}$ mbar ls ⁻¹
Pressure range	XHV to 2 bar (abs)
Differential pressure on the gate	≤ 2 bar
Differential pressure at opening	≤ 1 bar*
Lifetime	≥ 1000 cycles
Bake-out temperature**	≤ 300 °C open and closed
Heating and cooling rate	≤ 60 °C h ⁻¹
Material	valve body, mechanism, bellows AISI 316L (1.4404, 1.4435)
Seal: bonnet, plate	metal
Feedthrough	bellows
Mounting orientation	any
Valve position indication	visual (mechanical)
Conductance (molecular flow)	NW 16: 5 ls ⁻¹ / NW 40: 50 ls ⁻¹
Closing force	closes at a mechanical stop
Weight: NW 16 / 40	kg (lbs) 0.4 (0.9) / 1.9 (4.2)

* > 1 bar with reduced number of cycles

** Maximum values: depending on operating conditions and sealing materials

AGILENT HIGH PERFORMANCE VALVES

Features

- Body material: stainless steel
- FLEX VATRING configuration: see below
- Sealing surfaces are only elastically deformed
- Convenient operation with a standard hexagon wrench – no torque wrench required
- High conductance
- FLEX VATRING exchangeable twice

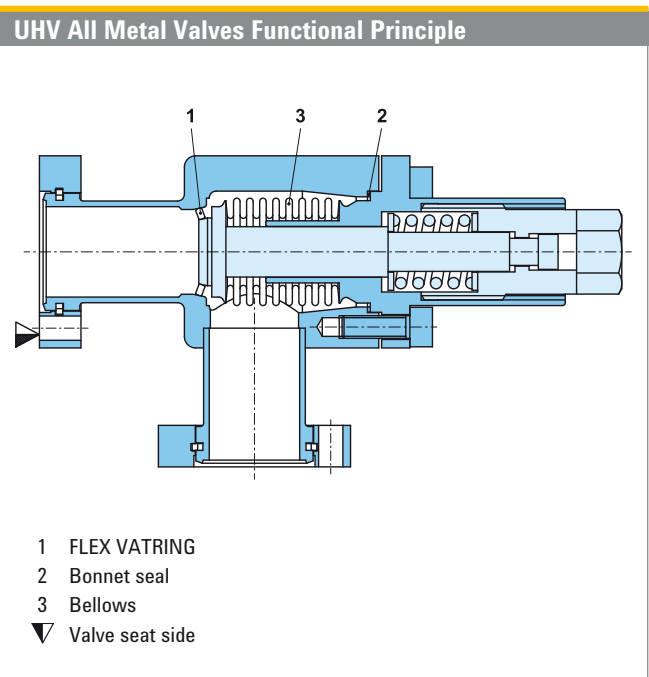

FLEX VATRING

This dynamic, all-metal sealing system is characterized by consistent sealing and closing forces. It enables achieving high sealing forces with comparably low axial forces. The seal mating surfaces are in stainless steel, and deformed elastically only.

The FLEX VATRING system is suitable for extreme UHV. It may be baked to 300 °C in open and closed position and reaches a lifetime of > 1 000 cycles if operated under clean conditions.

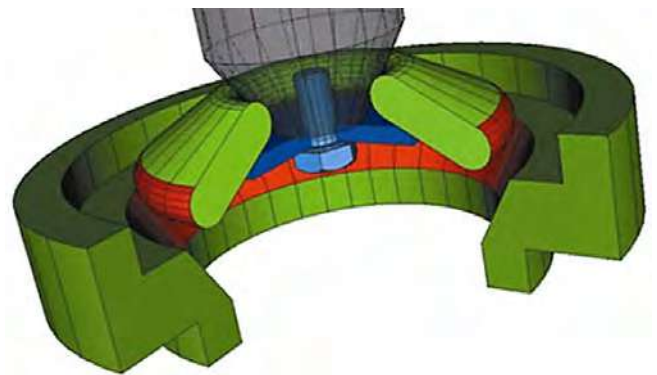

Ordering Information

Description UHV All Metal Valves	Part Number
Valve, ¼ Metal/Mini CFF	X3202-60097
Valve, All-Metal, 1 ½", RT-Angle	X3202-60098
Spare Parts	Part Number
Seal Kit, 1 st Replacement, UHV Series 54, ¾"	X3202-60107
Seal Kit, 2 nd Replacement, UHV Series 54, ¾"	X3202-60109
Seal Kit, 1 st Replacement, UHV Series 54, 1½"	X3202-60108
Seal Kit, 2 nd Replacement, UHV Series 54, 1½"	X3202-60110

VACUUM VALVES

Dimensions

Valve NW 16 ($\frac{5}{8}$ "

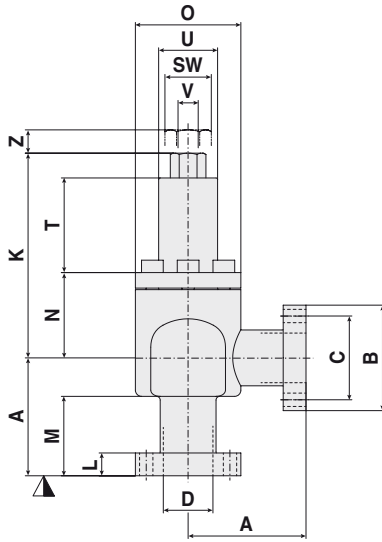

Valve NW 40 ($1\frac{1}{2}$ "

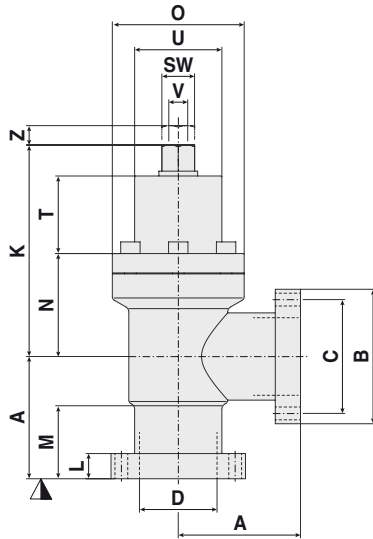

Flange NW 16–63 ($\frac{5}{8}$ "– $2\frac{1}{2}$ "

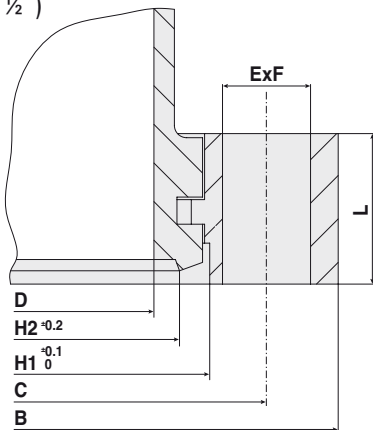

Models	DN 16 ($\frac{5}{8}$)	DN 40 ($1\frac{1}{2}$)
A	38 (1.50)	63 (2.48)
B	34 (1.34)	69.35 (2.73)
C	27 (1.06)	58.70 (2.31)
D	16 (0.63)	40 (1.57)
E x F	6 x 4.30 6 x 0.17	6 x 6.60 6 x 0.26
H1	21.40 (0.84)	48.30 (1.90)
H2	18.50 (0.73)	42 (1.65)
K	66 (2.60)	109.10 (4.30)
L	7.35 (0.29)	13 (0.51)
M	25.60 (1.01)	37.60 (1.48)
N	27.50 (1.08)	53.10 (2.09)
O	34 (1.34)	68 (2.68)
SW	10 (0.39)	17 (0.67)
T	30.50 (1.20)	40 (1.57)
U	19 (0.75)	45 (1.77)
V	6.35 (0.25)	9.53 (0.38)
Z	8.50 (0.33)	20 (0.79)

▽ Valve seat side

Dimensions: millimeters (inches)

STAINLESS STEEL TUBE VALVES

▶ Agilent Stainless Steel Valves



Agilent's family of vacuum stainless steel tube and in-line valves are designed to connect our rough vacuum and high vacuum pumps to your system. Delivering maximum conductance and sized for easy, convenient installation, these valves are ideally suited for systems requiring high reliability with low outgassing.

Excellent low outgassing characteristics are derived from the valve's fusion welded 304 stainless steel body, welded AM-350 stainless steel nesting bellows and small cross section elastomers and do not contain any blind internal cavities.

In combination with our popular hardware products, the new stainless steel valves offer a complete, bundled solution for

your vacuum system, making it possible for convenient one-stop shopping for everything required to connect Agilent vacuum pumps to your system.

A selection of port mounts...

Standard port mounts include:

- **Conflat metal seal flanges**, recommended for ultra-high vacuum service
- **KF and ISO flanges** for quick elastomer seal flanges, ideal for high vacuum applications that require frequent assembly and disassembly. See range of sizes in specifications table
- **Solenoids and position indicators** are optional and are sold separately.

Technical Specifications

Pressure range	Atmosphere to 1×10^{-8} mbar (7.5×10^{-9} Torr)					
Leak rate	$<1 \times 10^{-9}$ std cc/sec He					
Service life (bellows)	1.5 million cycles (minimum)					
Mounting position	any					
Baking temperature	Valve open 200 °C (392 °F)	Valve closed 150 °C (302 °F)	Position indicator (A/O optional) 70 °C (158 °F)		Solenoid (A/O optional) 60 °C (140 °F)	
Conductance	¾ in. Angle 6 l/sec	¾ in. In-line 5 l/sec	1 in. Angle 15 l/sec	1 in. In-line 13 l/sec	1½ in. Angle in. 48 l/sec	1½ in. In-line 44 l/sec
Materials	Valve body 304L SS	Bellows AM-350	Bellow flange 304 SS	Seal plate 304 SS	Bonnet gasket Viton (V747)	O-rings Viton (V747)
Pneumatic						
Air connection	¼ in. NPT					
Air pressure	60 psig (minimum)			80 psig (maximum)		
Open/Close time	¾ in. Valve <0.5 seconds		1 in. Valve <0.5 seconds		1½ in. Valve <0.8 seconds	
Solenoid (optional)	Supply Voltages: 110/120 V; 50/60 Hz; 220/240 V, 50/60 Hz; 24 VDC					
Volume of air	¾ in. Valve		1 in. Valve		1½ in. Valve	
Cylinder	0.049 L		0.049 L		0.1 L	
Valve position	No mechanical indicator (see optional position indicator)					
Position indicator (optional)	Voltage 5-240V DC/AC		Current 100 mA (maximum)		Power 10 W (maximum)	
Switching logic	SPST normally open					
Visual Indicator	Green LED					

VACUUM VALVES

Dimensions

Angle valves pneumatic

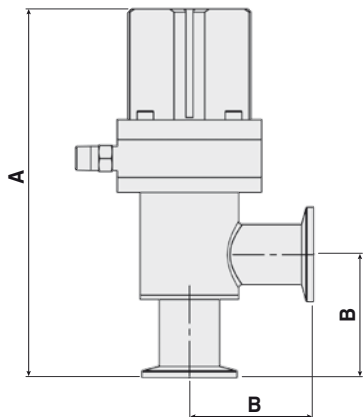

Size	A	B
NW 16	157.58 (6.22)	50.8 (8.2)
NW 25	155.7 (6.13)	52.07 (2.05)
NW 40	176.36 (6.94)	65 (2.56)
CF 1.33	162.02 (6.38)	55.25 (2.18)
CF 2.12	156.29 (6.15)	52.63 (2.07)
CF 2.75	177.87 (7.00)	66.51 (2.62)
¾ in.	157.58 (6.25)	50.8 (2.00)
1 in.	151.9 (5.98)	48.27 (1.9)
1½ in.	172.56 (6.79)	61.2 (2.41)

Dimensions: millimeters (inches)

In-line valves pneumatic

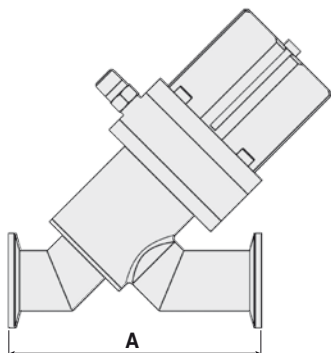

Size	A
NW16	101.6 (4.0)
NW25	106.7 (4.2)
NW40	130.05 (5.12)
CF 1.33	119.41 (4.70)
CF 2.12	107.79 (4.24)
CF 2.75	133.07 (5.24)
¾ in.	94 (3.7)
1 in.	99.1 (3.9)
1½ in.	122.4 (4.82)

Dimensions: millimeters (inches)

STAINLESS STEEL TUBE VALVES

Dimensions

Angle valves hand-operated

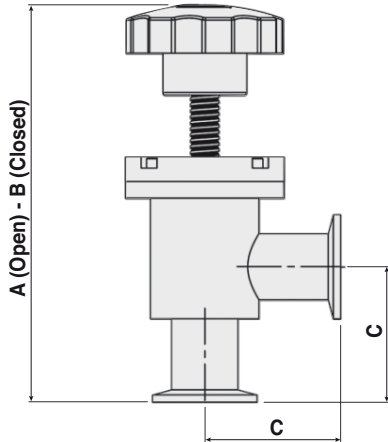

Size	A	B	C
NW 16	158.08 (6.22)	137.75 (5.42)	54.6 (2.15)
NW 25	152.4 (6.0)	132.07 (5.2)	52.07 (2.05)
NW 40	188.07 (7.41)	163.71 (6.45)	65 (2.56)
CF 1.33	158.72 (6.25)	138.27 (5.44)	55.12 (2.17)
CF 2.12	152.96 (6.02)	132.59 (5.22)	52.63 (2.07)
CF 2.75	189.58 (7.46)	165.22 (6.5)	66.51 (2.62)
¾ in.	154.28 (6.07)	133.75 (5.27)	50.8 (2.00)
1 in.	148.6 (5.85)	128.07 (5.04)	48.27 (1.90)
1½ in.	182.27 (7.18)	159.91 (6.3)	61.2 (2.41)

Dimensions: millimeters (inches)

In-line valves hand-operated

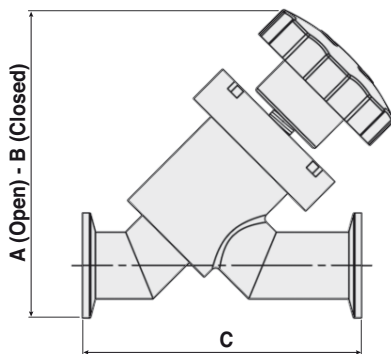

Size	A	B	C
NW 16	119.89 (4.72)	99.56 (3.92)	101.6 (4.0)
NW 25	117.66 (4.63)	97.33 (3.83)	106.7 (4.2)
NW 40	138.28 (5.44)	122.76 (4.83)	130.5 (5.12)
CF 1.33	119.87 (4.72)	99.54 (3.92)	119.4 (4.7)
CF 2.12	117.64 (4.63)	97.31 (3.83)	107.8 (4.24)
CF 2.75	147.28 (5.8)	122.76 (4.83)	133.07 (5.24)
¾ in.	119.89 (4.72)	99.56 (3.92)	94 (3.7)
1 in.	117.66 (4.63)	97.33 (3.83)	99.08 (3.9)
1½ in.	147.28 (5.8)	122.76 (4.83)	122.45 (4.82)

Dimensions: millimeters (inches)

VACUUM VALVES

Ordering Information

Ordering Instructions:

- Use only the Product Number list in the Product Number column.
- Numbers in the Option Number column are for reference only; use Short Description for ordering options.

Example Order: for a right angle, 1 1/3" pneumatic valve with position indicator for the valve, and a spare position indicator:

Item 1:

X3200A: Agilent Stainless Steel Tube Valve, Right Angle

Option: Pneumatically Operated, 1 1/3" ConFlat (021)

Option: Position indicator with LED light (060)

Item 2:

X3200-63000: Position indicator (as a separate spare part)

Note: Items are delivered as separate items in the same box, for assembly upon arrival.

For assistance with assembly, please see the video on **Agilent Chem Vacuum YouTube Channel**.

Configuration	Product Number	Option Number	Actuation	Size	Flange	Short Description
Right Angle Stainless Steel Tube Valve	X3200A	001	Manual	3/4"	ConFlat, 1 1/3"	Manually operated, 1 1/3" ConFlat
In-line Stainless Steel Tube Valve	X3201A	002	Manual	1"	ConFlat, 2 1/8"	Manually operated, 2 1/8" ConFlat
		003	Manual	1 1/2"	ConFlat, 2 3/4"	Manually operated, 2 3/4" ConFlat
		004	Manual	3/4"	Tube End, 3/4"	Manually operated, 3/4" Tube End
		005	Manual	1"	Tube End, 1"	Manually operated, 1" Tube End
		006	Manual	1 1/2"	Tube End, 1 1/2"	Manually operated, 1 1/2" Tube End
		007	Manual	3/4"	NW16	Manually operated, NW16
		008	Manual	1"	NW25	Manually operated, NW25
		009	Manual	1 1/2"	NW40	Manually operated, NW40
		021	Pneumatic	3/4"	ConFlat, 1 1/3"	Pneumatically operated, 1 1/3" ConFlat*
		022	Pneumatic	1"	ConFlat, 2 1/8"	Pneumatically operated, 2 1/8" ConFlat*
		023	Pneumatic	1 1/2"	ConFlat, 2 3/4"	Pneumatically operated, 2 3/4" ConFlat*
		024	Pneumatic	3/4"	Tube End, 3/4"	Pneumatically operated, 3/4" Tube End*
		025	Pneumatic	1"	Tube End, 1"	Pneumatically operated, 1" Tube End*
		026	Pneumatic	1 1/2"	Tube End, 1 1/2"	Pneumatically operated, 1 1/2" Tube End*
		027	Pneumatic	3/4"	NW16	Pneumatically operated, NW16*
		028	Pneumatic	1"	NW25	Pneumatically operated, NW25*
		029	Pneumatic	1 1/2"	NW40	Pneumatically operated, NW40*

* For pneumatically operated valves choose Solenoid and Position Indicator Options if desired - See Accessories Options table below.

Accessory Options (shipped with valves for installation upon arrival)

	Add Option Number
Solenoid, 24VDC	050
Solenoid, 110VAC	051
Solenoid, 220VAC	052
Position Indicator with LED	060

Service Parts (Ordered separately)

	Order Part Number
Solenoid, 24VDC	X3200-63024
Solenoid, 110VAC	X3200-63110
Solenoid, 220VAC	X3200-63220
Position Indicator with LED	X3200-63000

Spare Parts

	Part Number
Bellows Replacement Kit, NW16/25	X3200-67000
Bellows Replacement Kit, NW40	X3200-67001

ELECTROMAGNETIC BLOCK VALVES

▶ Agilent Electromagnetic Block Valves

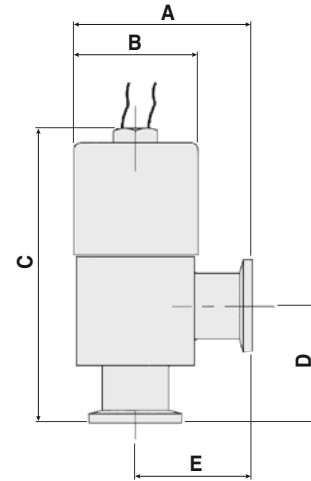

Models	A	B	C	D	E
NW16	64	58	113	40	40
	(2.50)	(2.28)	(4.43)	(1.58)	(1.58)
NW25	76	58	123	50	50
	(2.98)	(2.28)	(4.83)	(1.98)	(1.98)

Dimensions: millimeters (inches)

Features

- Reliable design
- Low cost
- Rapid spring-closed actuator
- KF Flange connections
- Single coil

Benefits

- Service-free operation
- Economical
- System protection on loss of power
- Ease of Installation
- Compact construction
- Rapid cycling

VACUUM VALVES

Technical Specifications

Vacuum range	Cleaned aluminum: atm to 10^{-6} Torr
Leak rate	$<1 \times 10^{-9}$ std cc/sec. (helium)
Operating temperature	15 °C min to 40 °C maximum
Bakeable to –	Non-operating (closed) 125 °C
Pulse voltage/Hold voltage	23 Watts
Service life	250,000 cycles
Conductance	NW16 – 2.2 l/s NW25 – 3.5 l/s
Speed to Open/Close	Open – 50 ms Close – 25 ms
Loss of power	Valve closes (in < 25 m/sec)

Ordering Information

Size	Voltage Option	Part Number	Shipping Weight kg (lbs)
Aluminum Body			
NW16	115 V; 50/60 Hz	L9940302	0.7 (1.5)
	220 V; 50/60 Hz	L9940304	0.7 (1.5)
	24 VDC	L9940306	0.7 (1.5)
	240 V; 50 Hz	L9940308	0.7 (1.5)
NW25	115 V; 50/60 Hz	L9942302	0.9 (2.0)
	220 V; 50/60 Hz	L9942304	0.9 (2.0)
	24 VDC	L9942306	0.9 (2.0)
	240 V; 50 Hz	L9942308	0.9 (2.0)

Description	Part Number	Shipping Weight kg (lbs)
Spare Parts		
Plunger Assembly – includes shaft, spring, and seal	L9987008	0.5 (1.0)
Operator, EMB, 115 V, 50/60 Hz	L9987002	0.5 (1.0)
Operator, EMB, 220 V, 50/60 Hz	L9987004	0.5 (1.0)
Operator, EMB, 240 V, 50 Hz	L9987009	1.0 (2.0)
Operator, EMB, 24 VDC	L9987006	0.5 (1.0)

VARIABLE LEAK VALVES

▶ Agilent Variable Leak Valve

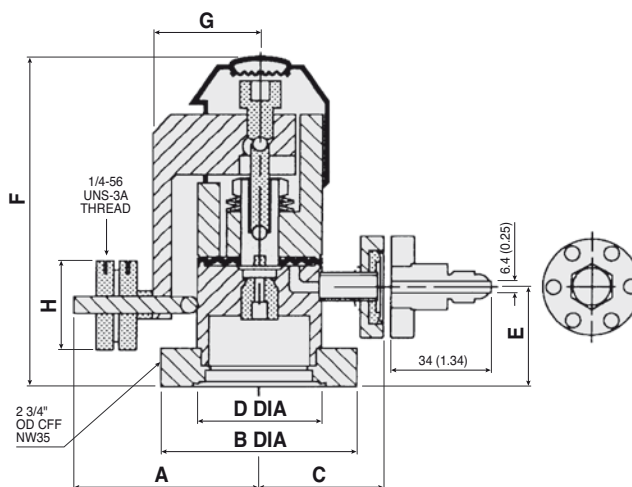

	A	B	C	D	E	F	G	H
mm	67	70	44	44	33	114	39	32
Inches	2 ²¹ / ₃₄	2 ³ / ₄	1 ³ / ₄	1 ³ / ₄	1 ⁵ / ₁₆	4 ¹ / ₂	1 ¹⁷ / ₃₂	1 ¹ / ₄

The variable leak valve includes a movable piston with an optically flat sapphire that meets a captured metal gasket. This forms a seal completely free from friction, seizing, and shear. The sapphire's movement is controlled through a threaded shaft-and-lever mechanism which provides a mechanical advantage of 13,000 to 1.

Technical Specifications

Controlled leak rate	10 ⁻¹⁰ Torr-l/sec (minimum)
Vacuum range	Atmosphere to below 10 ⁻¹¹ Torr (mbar)
Leak rate	No leak detectable on a helium mass spectrometer leak detector with sensitivity of 1 x 10 ⁻¹⁰ std cc/sec
Max flow conductance	6 l/m
Bakeable to –	450 °C

Ordering Information

Description	Part Number	Shipping Weight kg (lbs)
Sapphire-sealed variable leak valve and valve adjustment tools		
With 1 ¹ / ₃ in. (NW16) CFF gas inlet	9515106	1.8 (4.0)
Adapter kit, 1 ¹ / ₃ in. (NW16) CFF-to-flare-fitting adapter kit	9515117	0.5 (1.0)
Replacement gasket assembly	9535050	0.1 (0.3)
Replacement sapphire assembly	9530072	0.5 (1.0)
Sapphire removal tool	SR0061417400	0.2 (0.5)
Repair and tool kit includes fine screw assembly, handle, and collar adjusting knobs and spring driver assembly springs, sapphire assembly and gasket removal tool, brush, lubricant, 1 ¹ / ₄ and 5 ¹ / ₁₆ hex key wrenches and instruction manual	9620014	2.3 (5.0)



AGILENT VACUUM COMPONENTS

2	Introduction
3-38	ConFlat Flanges and Fittings
39-70	Klamp Flanges and Fittings
71-87	ISO Flanges and Fittings
88-89	Feedthroughs
90	Supplies, Greases and Lubricants



Agilent Technologies

FLANGES

Agilent Vacuum Flanges and Fittings

- Superior Quality Construction
- High Reliability
- Immediate Delivery



ConFlat Flanges & Fittings

Agilent's ConFlat Flanges have set the industry standard for vacuum flange performance. These flanges are available in rotatable and non-rotatable models, and in sizes from 1.33 in. to 13.25 in. OD.

Agilent utilizes unique manufacturing processes and techniques to ensure leak-free performance in ConFlat Flanges. Our unbending commitment to quality assures you of trouble-free vacuum performance of the Agilent ConFlat Flange.

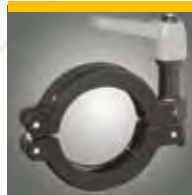

Klamp Flanges & Fittings

Designed in accordance with ISO standards the Agilent KF flange can be used in a variety of applications from atmospheric pressure to high vacuum. The KF flange is manufactured from 304 stainless steel and has a leak rate less than $1E^{-9}$ std cc/sec and can be baked to 150 °C when using a Viton O-Ring.

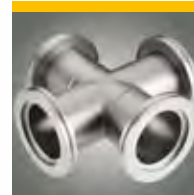

ISO Flanges & Fittings

ISO flanges and fittings are designed for applications requiring frequent disassembly and where tubing requirements generally exceed 2 in. OD. All ISO flanges and fittings listed are made of 304L stainless steel. These flanges can be used in a variety of applications from atmospheric to E^{-8} Torr. They can sustain a bakeout temperature of 150 °C when using Viton o-rings.



Feedthroughs

Rotary motion feedthrough.
High voltage feedthrough.



Supplies

Greases and lubricants.
Diffusion and mechanical pump fluids.

CONFLAT FLANGES

Agilent's extensive offering in vacuum flanges and fittings features an intuitive part numbering format. These part numbering format allows the customer to identify the product by the characters contained within the part number.

Depending on the product, the number and format of the characters in the part number will vary.

Please see the examples below:

CFF Example

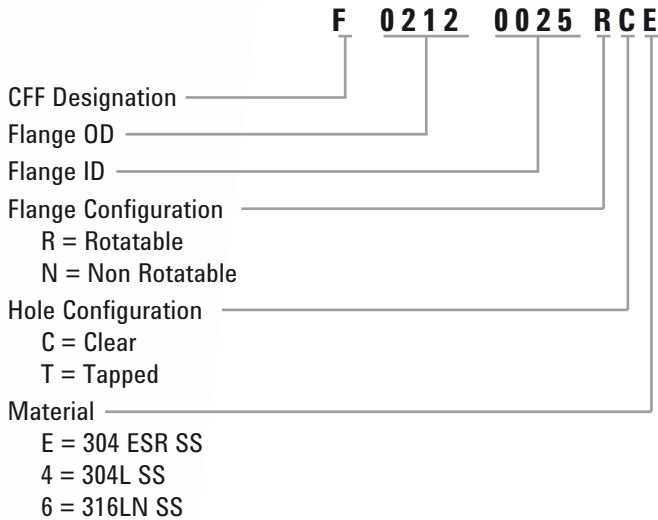

CFF Nipple Example



VACUUM COMPONENTS

ConFlat Flanges & Fittings	Page
ConFlat Flanges	4
Reducing Flanges.....	18
ConFlat Flange Accessory Dimensions.....	20
Bolt/Nut Sets – Reducing Flanges.....	21
Bolt Torques	21
Reducing Nipples – 304 Steel and 316LN SS	22
Half Nipples	23
Nipples	24
Elbows (90°).....	25
Tees	26
Crosses (4-Way).....	26
Flexible Couplings	27
CFF to KF Adapters	29
UHV Compression Ports	32
ConFlat to Compression Port Adapters	33
O-Ring Sealed Vacuum Compression Ports and Blank-offs.....	34
Viewports	35
Glass Adapters	37

CONFLAT FLANGES

▶ 1 1/3 in. (NW16CF) Non-Rotatable

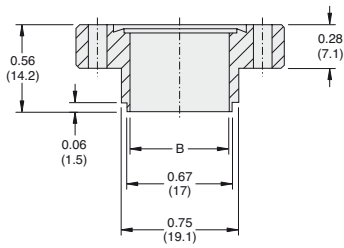

Fig. 3

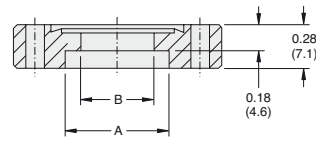

Fig. 4

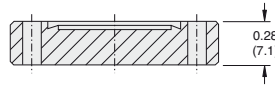

Fig. 1

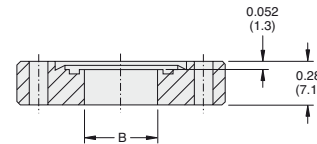

Fig. 2

Thru holes: 6 holes 0.172 (4.4) dia. thru, eq. spaced on 1.062 (26.9) dia. B.C.
 Tapped holes: 6 holes tapped 8-32 thru, eq. spaced on 1.062 (26.9) dia. B.C.

Dimensions: inches (millimeters)

Ordering Information

Type	304L SS		Fig. Number	Dimensions		Weight lbs (kg)
	Part Number	304 ESR SS Part Number		A in. (mm)	B in. (mm)	
Non-Rotatable	F01330000NC4	F01330000NCE	1	—	—	0.5 (0.2)
	F01330025NC4	F01330025NCE	2	—	0.26 (6.48)	0.5 (0.2)
	F01330038NC4	F01330038NCE	2	—	0.38 (9.70)	0.5 (0.2)
	F01330050NC4	N/A	2	—	0.51 (12.82)	0.5 (0.2)
	F01330075NC4W	F01330075NCEW	3	—	0.63 (16.00)	0.5 (0.2)
	F01330075NC4B	F01330075NCEB	4	0.76 (19.20)	0.63 (16.00)	0.5 (0.2)
Non-Rotatable	F01330000NT4	F01330000NTE	1	—	—	0.5 (0.2)
Tapped	F01330038NT4	N/A	2	—	0.38 (9.70)	0.5 (0.2)
	F01330050NT4	N/A	2	—	0.51 (12.82)	0.5 (0.2)
	F01330075NT4W	N/A	3	—	0.63 (16.00)	0.5 (0.2)
	F01330075NT4B	F01330075NTEB	4	0.76 (19.20)	0.63 (16.00)	0.5 (0.2)

Accessories

Description	Copper Part Number	Silver Plated Copper Part Number	Viton Part Number	Qty/Pkg	Weight lbs (kg)
Gaskets					
10-pack, individually sealed	FG0133CI	FG0133CIS	N/A	10	1.0 (0.5)
Package set	N/A	N/A	FG0133VU	5	0.5 (0.2)
Gasket clip set	GC0275S	N/A	N/A	10	0.5 (0.2)

VACUUM COMPONENTS

▶ 1 1/3 in. (NW16CF) Rotatable

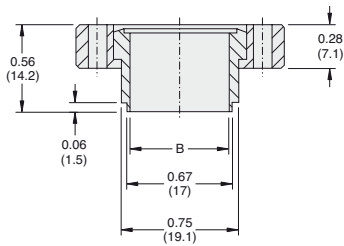

Fig. 7

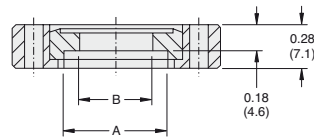

Fig. 8

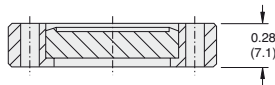

Fig. 5

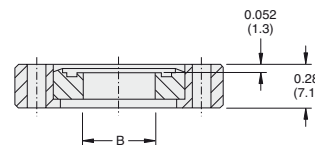

Fig. 6

Thru holes: 6 holes 0.172 (4.4) dia. thru, eq. spaced on 1.062 (26.9) dia. B.C.
 Tapped holes: 6 holes tapped 8-32 thru, eq. spaced on 1.062 (26.9) dia. B.C.

Dimensions: inches (millimeters)

Ordering Information

Type	304L SS Part Number	304 ESR SS Part Number	Fig. Number	Dimensions		Weight lbs (kg)
				A in. (mm)	B in. (mm)	
Rotatable	F01330000RC4	F01330000RCE	5	—	—	0.5 (0.2)
	F01330025RC4	N/A	6	—	0.26 (6.48)	0.5 (0.2)
	F01330038RC4	F01330038RCE	6	—	0.38 (9.70)	0.5 (0.2)
	F01330050RC4	F01330050RCE	6	—	0.51 (12.82)	0.5 (0.2)
	F01330075RC4W	F01330075RCEW	7	—	0.63 (16.00)	0.5 (0.2)
	F01330075RC4B	F01330075RCEB	8	0.76 (19.20)	0.63 (16.00)	0.5 (0.2)

Accessories

Description	Thread/Length	Socket Head Part Number	Silver Plated Socket Head Part Number	Qty/Pkg	Weight lbs (kg)
Nut and Bolt Sets					
Clear hole flanges*	8-32 x 3/4	FB0133C	FB0133CS	25	2.0 (0.9)
Tapped hole flanges**	8-32 x 1/2	FB0133T	FB0133TS	25	1.0 (0.5)
Plate Nut Sets					
12 plate nuts/24 bolts/washers		FP0133K	N/A	12/24	2.0 (0.9)
24 plate nuts only		FP0133N	N/A	24	1.0 (0.5)

* Includes nuts, washers, and bolts

** Includes washers and bolts only

CONFLAT FLANGES

▶ 2 3/4 in. (NW35CF) Non-Rotatable

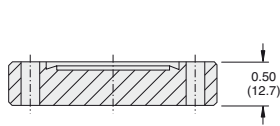

Fig. 1

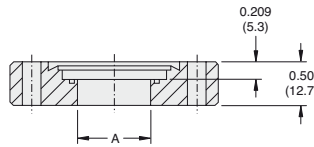

Fig. 2

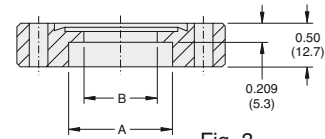

Fig. 3

Thru holes: 6 holes 0.265 (6.7) dia. thru, eq. spaced on 2.312 (58.7) dia. B.C.

Tapped holes: 6 holes tapped 1/4-28 thru, eq. spaced on 2.312 (58.7) dia. B.C.

Dimensions: inches (millimeters)

Ordering Information

Type	304L SS	304 ESR SS	Fig. Number	Dimensions		Weight lbs (kg)
	Part Number	Part Number		A in. (mm)	B in. (mm)	
Non-Rotatable	F02750000NC4	F02750000NCE	1	—	—	0.8 (0.4)
	F02750025NC4W	N/A	2	0.26 (6.48)	—	0.8 (0.4)
	F02750050NC4W	N/A	2	0.51 (12.83)	—	0.8 (0.4)
	F02750075NC4B	N/A	3	0.76 (19.30)	0.69 (17.53)	0.8 (0.4)
	F02750075NC4W	F02750075NCEW	2	0.76 (19.30)	—	0.8 (0.4)
	F02750100NC4B	F02750075NCEB	3	1.01 (25.65)	0.88 (22.23)	0.5 (0.2)
	F02750100NC4W	F02750100NCEW	2	1.01 (25.65)	—	0.8 (0.4)
	F02750125NC4	F02750125NCE	3	1.26 (32.00)	1.13 (28.56)	0.5 (0.2)
	F02750150NC4	F02750150NCE	3	1.51 (38.35)	1.38 (34.93)	0.5 (0.2)
	F02750162NC4	N/A	3	1.64 (41.53)	1.50 (38.10)	0.5 (0.2)
	F02750175NC4	F02750175NCE	3	1.76 (44.70)	1.63 (41.28)	0.5 (0.2)
Non-Rotatable Tapped	F02750000NT4	F02750000NTE	1	—	—	0.8 (0.4)
	F02750075NT4B	N/A	3	0.76 (19.30)	0.69 (17.53)	0.8 (0.4)
	F02750100NT4W	N/A	2	1.01 (25.65)	—	0.8 (0.4)
	F02750125NT4	F02750125NTE	3	1.26 (32.00)	1.13 (28.56)	0.5 (0.2)
	F02750150NT4	F02750150NTE	3	1.51 (38.35)	1.38 (34.93)	0.5 (0.2)
	F02750162NT4	N/A	3	1.64 (41.53)	1.50 (38.10)	0.5 (0.2)
	F02750175NT4	N/A	3	1.76 (44.70)	1.63 (41.28)	0.5 (0.2)

Accessories

Description	Copper Part Number	Silver Plated Copper Part Number	Viton Part Number	Qty/Pkg	Weight lbs (kg)
Gaskets					
10-pack, individually sealed	FG0275CI	FG0275CIS	N/A	10	0.5 (0.2)
10-pack, solid blank-off	FG0275CUB	N/A	N/A	10	1.0 (0.5)
Package set	N/A	N/A	FG0275VU	5	0.5 (0.2)
Gasket clip set	GC0275S	N/A	N/A	10	0.5 (0.2)

VACUUM COMPONENTS

▶ 2 3/4 in. (NW35CF) Rotatable

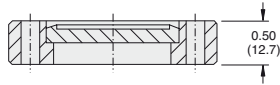

Fig. 4

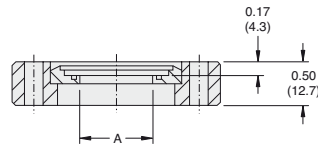

Fig. 5

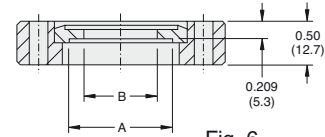

Fig. 6

Thru holes: 6 holes 0.265 (6.7) dia. thru, eq. spaced on 2.312 (58.7) dia. B.C.
Tapped holes: 6 holes tapped 1/4-28 thru, eq. spaced on 2.312 (58.7) dia. B.C.

Dimensions: inches (millimeters)

Ordering Information

Type	Material		Fig. Number	Dimensions		Weight lbs (kg)
	304L SS Part Number	304 ESR SS Part Number		A in. (mm)	B in. (mm)	
Rotatable	F02750000RC4	F02750000RCE	4	—	—	0.8 (0.4)
	F02750025RC4	N/A	5	.26 (6.48)	—	0.8 (0.4)
	F02750050RC4	N/A	5	.51 (12.83)	—	0.8 (0.4)
	F02750075RC4	N/A	6	.76 (19.30)	.63 (16.00)	0.8 (0.4)
	F02750100RC4	F02750100RCEB	6	1.01 (25.65)	.88 (22.23)	0.5 (0.2)
	N/A	F02750100RCEW	5	1.01 (25.65)	—	0.8 (0.4)
	F02750125RC4	F02750125RCE	6	1.26 (32.00)	1.13 (28.56)	0.5 (0.2)
	F02750150RC4	F02750150RCE	6	1.51 (38.35)	1.38 (34.93)	0.5 (0.2)
	F02750162RC4	N/A	6	1.65 (41.53)	1.50 (38.10)	0.5 (0.2)
	F02750175RC4	N/A	6	1.76 (44.70)	1.63 (41.28)	0.5 (0.2)

See page 13 for Accessories Ordering Information

Accessories

Description	Thread/Length	Hex Head Part Number	12-Point Bolt Part Number	Silver Plated 12-Point Bolt Part Number	Qty/Pkg	Weight lbs (kg)
Nut and Bolt Sets						
Clear hole flanges*	1/4-28 x 1 1/4	FB0275C06	FB0275C12	FB0275C12S	25	1.0 (0.5)
Tapped hole flanges**	1/4-28 x 7/8	FB0275T06	FB0275T12	FB0275T12S	25	0.5 (0.2)
Plate Nut Sets						
12 plate nuts/24 bolts/24 washers		FP0275K06	FP0275K12	N/A	12/24	2.0 (0.9)
24 plate nuts only		FP0275N	N/A	N/A	12/24	2.0 (0.9)

* Includes nuts, washers, and bolts

** Includes washers and bolts only

CONFLAT FLANGES

▶ 3 3/8 in. (NW50CF) Non-Rotatable

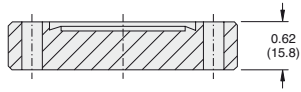

Fig. 1

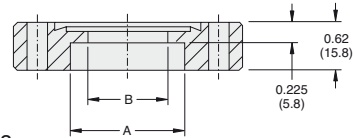

Fig. 2

Thru holes: 8 holes 0.332 (8.4) dia. thru, eq. spaced on 2.850 (72.4) dia. B.C.

Tapped holes: 8 holes tapped 5/16-24 thru, eq. spaced on 2.850 (72.4) dia. B.C.

Dimensions: inches (millimeters)

Ordering Information

Type	304L SS Part Number	304 ESR SS Part Number	Fig. Number	Dimensions		Weight lbs (kg)
				A in. (mm)	B in. (mm)	
Non-Rotatable	F03380000NC4	N/A	1	—	—	2.0 (0.9)
	F03380200NC4	N/A	2	2.01 (51.18)	1.88 (47.63)	1.5 (0.7)
Non-Rotatable Tapped	F03380000NT4	N/A	1	—	—	2.0 (0.9)
	F03380200NT4	N/A	2	2.01 (51.18)	1.88 (47.63)	1.5 (0.7)

VACUUM COMPONENTS

▶ 3 3/8 in. (NW50CF) Rotatable

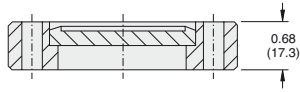

Fig. 3

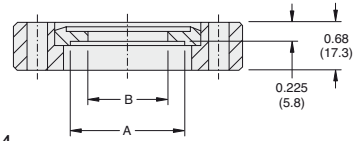

Fig. 4

Thru holes: 8 holes 0.332 (8.4) dia. thru, eq. spaced on 2.850 (72.4) dia. B.C.

Tapped holes: 8 holes tapped 5/16-24 thru, eq. spaced on 2.850 (72.4) dia. B.C.

Dimensions: inches (millimeters)

Ordering Information

Type	304L SS Part Number	304 ESR SS Part Number	Fig. Number	Dimensions		Weight lbs (kg)
				A in. (mm)	B in. (mm)	
Rotatable	F03380000RC4	N/A	3	—	—	2.0 (0.9)
	F03380150RC4	N/A	4	1.51 (38.35)	1.38 (34.93)	1.5 (0.7)
	F03380200RC4	N/A	4	2.02 (51.18)	1.88 (47.63)	1.5 (0.7)

Accessories

Description	Copper Part Number	Silver Plated Copper Part Number	Viton Part Number	Qty/Pkg	Weight lbs (kg)
Gaskets					
10-pack, individually sealed	FG0338CI	FG0338CIS	N/A	10	1.0 (0.5)
1-pack	N/A	N/A	FG0338VU	1	0.5 (0.2)
Gasket clip set	GC0275S	N/A	N/A	10	0.5 (0.2)

Description	Thread/Length	Hex Head Part Number	12-Point Bolt Part Number	Silver Plated 12-Point Bolt Part Number	Qty/Pkg	Weight lbs (kg)
Nut and Bolt Sets						
Clear hole flanges*	5/16-24 x 1 3/4	FB0338C06	FB0338C12	FB0338C12S	25	2.0 (0.9)
Tapped hole flanges**	5/16-24 x 1 1/4	FB0450T06	FB0450T12	FB0450T12S	25	2.0 (0.9)

* Includes nuts, washers, and bolts

** Includes washers and bolts only

CONFLAT FLANGES

▶ 4 1/2 in. (NW63CF) Non-Rotatable

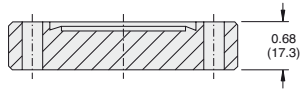

Fig. 1

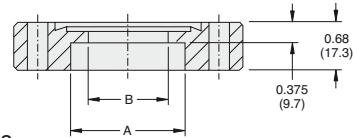

Fig. 2

Thru holes: 8 holes 0.332 (8.4) dia. thru, eq. spaced on 3.628 (92.2) dia. B.C.

Tapped holes: 8 holes tapped 5/16-24 thru, eq. spaced on 3.628 (92.2) dia. B.C.

Dimensions: inches (millimeters)

Ordering Information

Type	304L SS Part Number	304 ESR SS Part Number	Fig. Number	Dimensions		Weight lbs (kg)
				A in. (mm)	B in. (mm)	
Non-Rotatable	F04500000NC4	F04500000NCE	1	—	—	3.0 (1.4)
	F04500150NC4	N/A	2	1.51 (38.35)	1.38 (34.93)	2.5 (1.1)
	F04500200NC4	N/A	2	2.01 (51.05)	1.88 (47.63)	2.5 (1.1)
	F04500250NC4	F04500250NCE	2	2.51 (63.75)	2.38 (60.33)	2.5 (1.1)
Non-Rotatable Tapped	F04500000NT4	F04500000NTE	1	—	—	3.0 (1.4)
	F04500150NT4	N/A	2	1.51 (38.35)	1.38 (34.93)	2.5 (1.1)
	F04500200NT4	N/A	2	2.01 (51.05)	1.88 (47.63)	2.5 (1.1)
	F04500250NT4	N/A	2	2.51 (63.75)	2.38 (60.33)	2.5 (1.1)

VACUUM COMPONENTS

▶ 4 1/2 in. (NW63CF) Rotatable

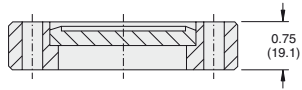

Fig. 3

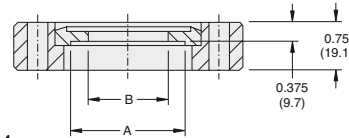

Fig. 4

Thru holes: 8 holes 0.332 (8.4) dia. thru, eq. spaced on 3.628 (92.2) dia. B.C.
Tapped holes: 8 holes tapped 5/16-24 thru, eq. spaced on 3.628 (92.2) dia. B.C.

Dimensions: inches (millimeters)

Ordering Information

Type	304L SS Part Number	304 ESR SS Part Number	Fig. Number	Dimensions		Weight lbs (kg)
				A in. (mm)	B in. (mm)	
Rotatable	F0450000RC4	N/A	3	—	—	3.0 (1.4)
	F04500200RC4	N/A	4	2.01 (51.05)	1.88 (47.63)	2.5 (1.1)
	F04500250RC4	N/A	4	2.51 (63.75)	2.38 (60.33)	2.5 (1.1)

Accessories

Description	Copper Part Number	Silver Plated Copper Part Number	Viton Part Number	Qty/Pkg	Weight lbs (kg)
Gaskets					
10-pack, individually sealed	FG0450CI	FG0450CIS	N/A	10	2.0 (0.9)
1-pack	N/A	N/A	FG0450VU	1	0.5 (0.2)
Gasket clip set	GC0275S	N/A	N/A	10	0.5 (0.2)

Description	Thread/Length	Hex Head Part Number	12-Point Bolt Part Number	Silver Plated 12-Point Bolt Part Number	Qty/Pkg	Weight lbs (kg)
Nut and Bolt Sets						
Clear hole flanges*	5/16-24 x 2	FB0450C06	FB0450C12	FB0450C12S	25	1.5 (0.7)
Tapped hole flanges**	5/16-24 x 1 1/4	FB0450T06	FB0450T12	FB0450T12S	25	1.5 (0.7)

* Includes nuts, washers, and bolts

** Includes washers and bolts only

CONFLAT FLANGES

▶ 6 in. (NW100CF) Non-Rotatable

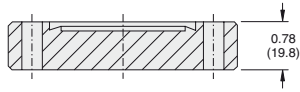

Fig. 1

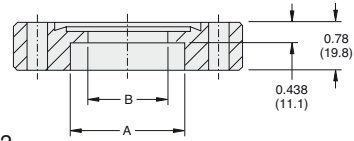

Fig. 2

Thru holes: 16 holes 0.332 (8.4) dia. thru, eq. spaced on 5.128 (130.3) dia. B.C.
 Tapped holes: 16 holes tapped $\frac{5}{16}$ -24 thru, eq. spaced on 5.128 (130.3) dia. B.C.

Dimensions: inches (millimeters)

Ordering Information

Type	304L SS Part Number	304 ESR SS Part Number	Fig. Number	Dimensions		Weight lbs (kg)
				A in. (mm)	B in. (mm)	
Non-Rotatable	F06000000NC4	F06000000NCE	1	—	—	6.5 (2.9)
	F06000400NC4	F06000400NCE	2	4.01 (101.85)	3.81 (96.77)	4.5 (2.0)
Non-Rotatable	F06000000NT4	N/A	1	—	—	6.5 (2.9)
Tapped	F06000400NT4	F06000400NTE	2	4.01 (101.85)	3.81 (96.77)	4.5 (2.0)

▶ 6 in. (NW100CF) Rotatable

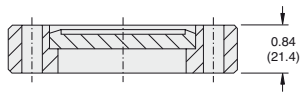

Fig. 3

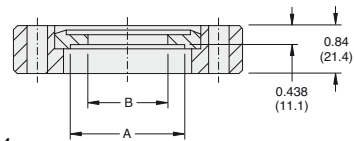

Fig. 4

Thru holes: 16 holes 0.332 (8.4) dia. thru, eq. spaced on 5.128 (130.3) dia. B.C.
 Tapped holes: 16 holes tapped $\frac{5}{16}$ -24 thru, eq. spaced on 5.128 (130.3) dia. B.C.

Dimensions: inches (millimeters)

Ordering Information

Type	304L SS Part Number	304 ESR SS Part Number	Fig. Number	Dimensions		Weight lbs (kg)
				A in. (mm)	B in. (mm)	
Rotatable	F06000000RC4	F06000000RCE	3	—	—	6.5 (2.9)
	F06000400RC4	N/A	4	4.01 (101.85)	3.81 (96.77)	4.5 (2.0)

Accessories

Description	Copper Part Number	Silver Plated Copper Part Number	Viton Part Number	Qty/Pkg	Weight lbs (kg)
Gaskets					
10-pack, individually sealed	FG0600CI	FG0600CIS	N/A	10	1.5 (0.7)
1-pack	N/A	N/A	FG0600VU	1	1.0 (0.5)
Gasket clip set	GC0275S	N/A	N/A	10	.5 (0.2)

VACUUM COMPONENTS

Accessories (Cont'd)

Description	Thread/Length	Hex Head Part Number	12-Point Bolt Part Number	Silver Plated 12-Point Bolt Part Number	Qty/Pkg	Weight lbs (kg)
Nut and Bolt Sets						
Clear hole flanges						
Non-rotatable*	5/16-24 x 2	FB0450C06	FB0450C12	FB0450C12S	25	2.0 (0.9)
Clear hole flanges						
Rotatable*	5/16-24 x 2 1/4	FB0600C06	FB0600C12	FB0600C12S	25	2.0 (0.9)
Tapped hole flanges**	5/16-24 x 1 1/4	FB0450T06	FB0450T12	FB0450T12S	25	1.5 (0.7)

* Includes nuts, washers, and bolts

** Includes washers and bolts only

▶ 6 3/4 in. (NW130CF) Non-Rotatable

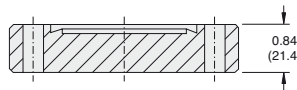

Fig. 1

Thru holes: 18 holes 0.332 (8.4) dia. thru, eq. spaced on 5.969 (151.6) dia. B.C.

Tapped holes: 18 holes tapped 5/16-24 thru, eq. spaced on 5.969 (151.6) dia. B.C.

Dimensions: inches (millimeters)

Ordering Information

Type	304L SS	304 ESR SS	Fig. Number	Dimensions		Weight lbs (kg)
	Part Number	Part Number		A in. (mm)	B in. (mm)	
Non-Rotatable	F06750000NC4	F06750000NCE	1	-	-	8.0 (3.6)

Accessories

Description	Copper Part Number	Silver Plated Copper Part Number	Viton Part Number	Qty/Pkg	Weight lbs (kg)
Gaskets					
10-Pack, individually sealed	FG0675CI	FG0675CIS	N/A	10	2.0 (0.9)
1-pack	N/A	N/A	FG0675VU	1	1.0 (0.5)
Gasket clip set	GC0275S	N/A	N/A	10	0.5 (0.2)

Description	Thread/Length	Hex Head Part Number	12-Point Bolt Part Number	Silver Plated 12-Point Bolt Part Number	Qty/Pkg	Weight lbs (kg)
Nut and Bolt Sets						
Clear hole flanges*	5/16-24 x 2 1/4	FB0600C06	FB0600C12	FB0600C12S	25	2.0 (0.9)
Tapped hole flanges**	5/16-24 x 1 3/4	FB0800T06	FB0800T12	FB0800T12S	25	2.0 (0.9)

* Includes nuts, washers, and bolts

** Includes washers and bolts only

CONFLAT FLANGES

▶ 8 in. (NW150CF) Non-Rotatable

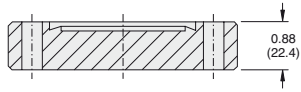

Fig. 1

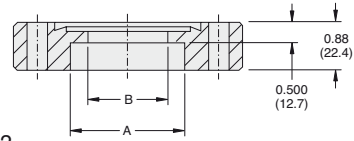

Fig. 2

Thru holes: 20 holes 0.332 (8.4) dia. thru, eq. spaced on 7.128 (181.1) dia. B.C.
 Tapped holes: 20 holes tapped $\frac{5}{16}$ -24 thru, eq. spaced on 7.128 (181.1) dia. B.C.

Dimensions: inches (millimeters)

Ordering Information

Type	304L SS Part Number	304 ESR SS Part Number	Fig. Number	Dimensions		Weight lbs (kg)
				A in. (mm)	B in. (mm)	
Non-Rotatable	F08000000NC4	F08000000NCE	1	—	—	12.5 (5.6)
	F08000600NC4	F08000600NCE	2	6.02 (152.91)	5.81 (147.57)	5.8 (2.6)
Non-Rotatable Tapped	F08000000NT4	N/A	1	—	—	12.5 (5.6)
	F08000600NT4	N/A	2	6.02 (152.91)	5.81 (147.57)	5.8 (2.6)

VACUUM COMPONENTS

▶ 8 in. (NW150CF) Rotatable

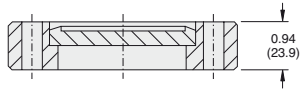

Fig. 3

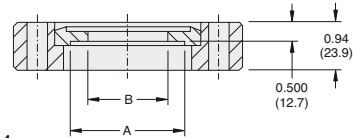

Fig. 4

Thru holes: 20 holes 0.332 (8.4) dia. thru, eq. spaced on 7.128 (181.1) dia. B.C.
 Tapped holes: 20 holes tapped 5/16-24 thru, eq. spaced on 7.128 (181.1) dia. B.C.

Dimensions: inches (millimeters)

Ordering Information

Type	304L SS	304 ESR SS	Fig. Number	Dimensions		Weight lbs (kg)
	Part Number	Part Number		A in. (mm)	B in. (mm)	
Rotatable	F08000000RC4	N/A	3	—	—	10.0 (4.5)
	F08000600RC4	F08000600RCE	4	6.02 (152.91)	5.81 (147.57)	7.0 (3.2)

Accessories

Description	Copper Part Number	Silver Plated Copper Part Number	Viton Part Number	Qty/Pkg	Weight lbs (kg)
Gaskets					
10-pack, individually sealed	FG0800CI	FG0800CIS	N/A	10	2.5 (1.1)
1-pack	N/A	N/A	FG0800VU	1	1.0 (0.5)
Gasket clip set	GC0275S	N/A	N/A	10	0.5 (0.2)

Description	Thread/Length	Hex Head Part Number	12-Point Bolt Part Number	Silver Plated 12-Point Bolt Part Number	Qty/Pkg	Weight lbs (kg)
Nut and Bolt Sets						
Clear hole flanges*	5/16-24 x 2 1/4	FB0600C06	FB0600C12	FB0600C12S	25	2.0 (0.9)

* Includes nuts, washers, and bolts

** Includes washers and bolts only

CONFLAT FLANGES

▶ 10 in. (NW200CF) Non-Rotatable

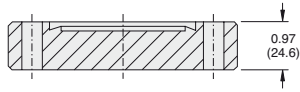

Fig. 1

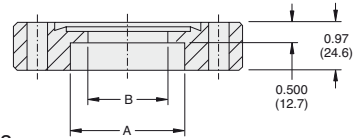

Fig. 2

Thru holes: 24 holes 0.332 (8.4) dia. thru, eq. spaced on 9.128 (231.9) dia. B.C.
 Tapped holes: 24 holes tapped 5/16-24 thru, eq. spaced on 9.128 (231.9) dia. B.C.

Dimensions: inches (millimeters)

Ordering Information

Type	304L SS Part Number	304 ESR SS Part Number	Fig. Number	Dimensions		Weight lbs (kg)
				A in. (mm)	B in. (mm)	
Non-Rotatable	F1000000NC4	F1000000NCE	1	—	—	21.0 (9.5)
	F10000800NC4	F10000800NCE	2	8.04 (204.22)	7.81 (198.37)	8.0 (3.6)
Non-Rotatable Tapped	F10000000NT4	N/A	1	—	—	21.0 (9.5)

Accessories

Description	Copper Part Number	Silver Plated Copper Part Number	Viton Part Number	Qty/Pkg	Weight lbs (kg)
Gaskets					
10-pack, individually sealed	FG1000CI	FG1000CIS	N/A	10	3.0 (1.3)
1-pack	N/A	N/A	FG1000VU	1	1.0 (0.5)
Gasket clip set	GC0275S	N/A	N/A	10	0.5 (0.2)

Description	Thread/Length	Hex Head Part Number	12-Point Bolt Part Number	Silver Plated 12-Point Bolt Part Number	Qty/Pkg	Weight lbs (kg)
Nut and Bolt Sets						
Clear hole flanges*	5/16-24 x 2 1/2	FB1000C06	FB1000C12	FB1000C12S	25	2.0 (0.9)
Tapped hole flanges**	5/16-24 x 1 3/4	FB0800T06	FB0800T12	FB0800T12S	25	1.5 (0.7)

* Includes nuts, washers, and bolts

** Includes washers and bolts only

VACUUM COMPONENTS

▶ 13 ¼ in. (NW275CF) Non-Rotatable

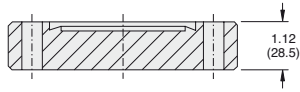

Fig. 1

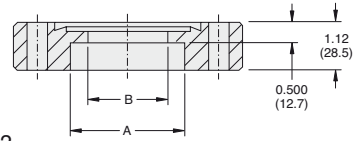

Fig. 2

Thru holes: 30 holes 0.390 (9.9) dia. thru, eq. spaced on 12.060 (306.3) dia. B.C.
Tapped holes: 30 holes tapped ⅜-24 thru, eq. spaced on 12.060 (306.3) dia. B.C.

Dimensions: inches (millimeters)

Ordering Information

Type	304L SS Part Number	304 ESR SS Part Number	Fig. Number	Dimensions		Weight lbs (kg)
				A in. (mm)	B in. (mm)	
Non-Rotatable	F13250000NC4	F13250000NCE	1	—	—	41.0 (18.6)
	F13251000NC4	N/A	2	10.03 (254.76)	9.86 (250.44)	18.0 (8.2)

Accessories

Description	Copper Part Number	Qty/Pkg	Weight lbs (kg)
Gaskets			
1-pack, individually sealed	FG1325CI	1	0.5 (0.2)
Gasket clip set	GC0275S	10	0.5 (0.2)

Description	Thread/Length	Hex Head Part Number	Qty/Pkg	Weight lbs (kg)
Nut and Bolt Sets				
Clear hole flanges*	⅜-24 x 3	FB1325C06	30	2.0 (0.9)

* Includes nuts, washers, and bolts

CONFLAT FLANGES

▶ 2¾ in. - 10 in. Reducing

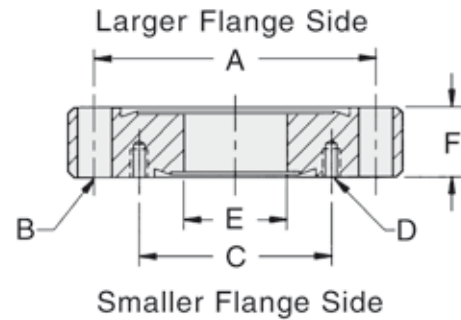

Ordering Information

Size	304L SS Part Number	304 ESR SS Part Number	Larger Flange Dimensions		
			Bolt Circle A in. (mm)	# of Holes	Hole Diam. B in. (mm)
2¾ in.	N/A	FR02750133E	2.31 (58.72)	6	0.27 (6.73)
4½ in.	N/A	FR04500133E	3.63 (92.15)	8	0.33 (8.43)
	N/A	FR04500275E	3.63 (92.15)	8	0.33 (8.43)
6 in.	FR060001334	N/A	5.13 (130.25)	16	0.33 (8.43)
	FR060002124	N/A	5.13 (130.25)	16	0.33 (8.43)
	FR060002754	FR06000275E	5.13 (130.25)	16	0.33 (8.43)
	FR060003384	N/A	5.13 (130.25)	16	0.33 (8.43)
	FR060004504	FR06000450E	5.13 (130.25)	16	0.33 (8.43)
8 in.	FR080001334	N/A	7.13 (181.05)	20	0.33 (8.43)
	FR080002754	FR08000275E	7.13 (181.05)	20	0.33 (8.43)
	FR080003384	N/A	7.13 (181.05)	20	0.33 (8.43)
	FR080004504	FR08000450E	7.13 (181.05)	20	0.33 (8.43)
	FR080006004	FR08000600E	7.13 (181.05)	20	0.33 (8.43)
	FR080006754T*	N/A	7.13 (181.05)	20	(⁵ / ₁₆ -24)
10 in.	FR100001334	N/A	9.13 (231.85)	24	0.33 (8.43)
	FR100002754	N/A	9.13 (231.85)	24	0.33 (8.43)
	FR100003384	N/A	9.13 (231.85)	24	0.33 (8.43)
	FR100004504	N/A	9.13 (231.85)	24	0.33 (8.43)
	FR100006004	N/A	9.13 (231.85)	24	0.33 (8.43)
	FR100008004	N/A	9.13 (231.85)	24	0.33 (8.43)

* Both sets of bolt holes are tapped.

VACUUM COMPONENTS

Smaller Flange Dimensions			Thread D	ID E in. (mm)	Thickness F in. (mm)	Weight lbs (kg)
Bolt Circle C in. (mm)	# of Holes					
1.06 (27.00)	6		8-32	0.62 (15.75)	0.50 (12.70)	0.8 (0.3)
1.06 (26.98)	6		8-32	0.62 (15.75)	0.68 (17.27)	3.0 (1.4)
2.31 (58.73)	6		¼-28	1.50 (38.10)	0.68 (17.27)	2.5 (1.1)
1.06 (26.98)	6		8-32	0.62 (15.75)	0.78 (19.81)	6.0 (2.7)
1.63 (41.40)	4		¼-28	1.00 (25.40)	0.78 (19.81)	5.5 (2.5)
2.31 (58.73)	6		¼-28	1.50 (38.10)	0.78 (19.81)	5.5 (2.5)
2.85 (72.39)	8		⅝-24	1.88 (47.63)	0.78 (19.81)	5.0 (2.3)
3.63 (92.15)	8		⅝-24	2.50 (63.50)	0.78 (19.81)	4.5 (2.0)
1.06 (26.98)	6		8-32	0.62 (15.75)	0.88 (22.35)	12.0 (5.4)
2.31 (58.73)	6		¼-28	1.50 (38.10)	0.88 (22.35)	12.0 (5.4)
2.85 (72.39)	8		⅝-24	2.00 (50.80)	0.88 (22.35)	11.0 (5.0)
3.63 (92.15)	8		⅝-24	2.50 (63.50)	0.88 (22.35)	11.0 (5.0)
5.13 (130.25)	16		⅝-24	4.00 (101.60)	0.88 (22.35)	10.0 (4.5)
5.97 (151.61)	18		⅝-24	5.00 (127.00)	0.88 (22.35)	10.0 (4.5)
1.06 (26.98)	6		8-32	0.62 (15.75)	0.97 (24.64)	20.0 (9.0)
2.31 (58.73)	6		¼-28	1.50 (38.10)	0.97 (24.64)	20.0 (9.0)
2.85 (72.40)	8		⅝-24	2.00 (50.80)	0.97 (24.64)	20.0 (9.0)
3.63 (92.11)	8		⅝-24	2.50 (63.50)	0.97 (24.64)	20.0 (9.0)
5.13 (130.25)	16		⅝-24	4.00 (101.60)	0.97 (24.64)	17.0 (7.7)
7.13 (181.05)	20		⅝-24	6.00 (152.40)	0.97 (24.64)	17.0 (7.7)

CONFLAT FLANGES

▶ Accessories

Accessories – Gaskets

Size	Gasket Material	Description	Part Number	Qty/Pkg	Weight lbs (kg)
1 1/8 in.	Copper	Individually sealed	FG0133CI	10	1.0 (0.5)
	Viton	Packaged together	FG0133VU	5	0.5 (0.2)
	Silver plated copper	Packaged together	FG0133CIS	10	1.0 (0.5)
		Clip set	GC0275S	10	1.0 (0.5)
2 1/8 in.	Copper	Individually sealed	FG0212CI	10	1.0 (0.5)
	Viton	Packaged together	FG0212VU	5	0.5 (0.2)
	Silver plated copper	Individually sealed	FG0212CIS	10	1.0 (0.5)
		Clip set	GC0275S	10	0.5 (0.2)
2 3/4 in.	Copper	Individually sealed	FG0275CI	10	1.0 (0.5)
	Viton	Packaged together	FG0275VU	5	0.5 (0.2)
	Silver plated copper	Packaged together	FG0275CIS	10	1.0 (0.5)
		Clip set	GC0275S	10	1.0 (0.5)
3 3/8 in.	Copper	Individually sealed	FG0338CI	10	1.0 (0.5)
	Viton	Individually sealed	FG0338VU	1	0.5 (0.2)
	Silver plated copper	Packaged together	FG0338CIS	10	1.0 (0.5)
		Clip set	GC0275S	10	1.0 (0.5)
4 1/2 in.	Copper	Individually sealed	FG0450CI	10	1.0 (0.5)
	Viton	Individually sealed	FG0450VU	1	0.5 (0.2)
	Silver plated copper	Packaged together	FG0450CIS	10	1.0 (0.5)
		Clip set	GC0275S	10	1.0 (0.5)
4 5/8 in.	Copper	Individually sealed	FG0462CI	10	1.0 (0.5)
	Viton	Individually sealed	FG0462VU	1	0.5 (0.2)
	Silver plated copper	Individually sealed	FG0462CIS	10	2.0 (0.9)
		Clip set	GC0275S	10	0.5 (0.2)
6 in.	Copper	Individually sealed	FG0600CI	10	2.0 (0.9)
	Viton	Individually sealed	FG0600VU	1	0.5 (0.2)
	Silver plated copper	Packaged together	FG0600CIS	10	2.0 (0.9)
		Clip set	GC0275S	10	1.0 (0.5)
6 3/4 in.	Copper	Individually sealed	FG0675CI	10	2.0 (0.9)
	Viton	Individually sealed	FG0675VU	1	0.5 (0.2)
	Silver plated copper	Packaged together	FG0675CIS	10	2.0 (0.9)
		Clip set	GC0275S	10	1.0 (0.5)
8 in.	Copper	Individually sealed	FG0800CI	10	2.0 (0.9)
	Viton	Individually sealed	FG0800VU	1	0.5 (0.2)
	Silver plated copper	Packaged together	FG0800CIS	10	2.0 (0.9)
		Clip set	GC0275S	10	1.0 (0.5)
10 in.	Copper	Individually sealed	FG1000CI	10	2.5 (1.1)
	Viton	Individually sealed	FG1000VU	1	0.5 (0.2)
	Silver plated copper	Packaged together	FG1000CIS	10	2.5 (1.1)
		Clip set	GC0275S	10	1.0 (0.5)
12 in.	Copper	Individually sealed	FG1200CI	1	2.5 (1.1)
	Viton	Individually sealed	FG1200VU	1	0.5 (0.2)
	Silver plated copper	Individually sealed	FG1200CIS	1	2.0 (0.9)
		Clip set	GC0275S	10	0.5 (0.2)
13 1/4 in.	Copper	Individually sealed	FG1325CI	1	3.5 (1.6)

Recommended Torque Specifications for Tightening ConFlat Bolts

Flange Size	Size/Thread	Torque – inch lbs
For ConFlats 1 1/8 in.	(8-32)	51
For ConFlats 2 1/8 in. and 2 3/4 in.	(1/4-28)	96
For ConFlats 3 3/8 in. to 12 in.	(5/16-24)	192
For ConFlats 13 1/4 in.	(3/8-24)	345

VACUUM COMPONENTS

Accessories – Bolt Sets for Double-Sided Flanges

Size	Nut and Bolt Sets	Thread/Length	Hex Head Part Number	12-Point Bolt Part Number	Qty/Pkg	Shipping Weight lbs (kg)
2 ¼ in.	Clear hole flanges*	¼-28 x 2 ¼	FB0275CD06	FB0275CD12	6	1.0 (0.5)
4 ½ in.	Clear hole flanges*	5/16-24 x 2 ½	FB0450CD06	FB0450CD12	10	1.0 (0.5)
6 in.	Clear hole flanges*	5/16-24 x 2 ¾	FB0600CD06	N/A	16	2.0 (0.9)
8 in.	Clear hole flanges*	5/16-24 x 3 ¼	FB0800CD06	N/A	20	3.0 (1.4)
10 in.	Clear hole flanges*	5/16-24 x 3 ½	FB1000CD06	N/A	24	3.5 (1.6)
13 ¼ in.	Clear hole flanges*	¾-24 x 4	FB1325CD06	N/A	30	4.0 (1.8)

* Includes nuts, washers, and bolts

Accessories – Bolt Sets for CF to KF Adapters

Size	Nut and Bolt Sets	Hex Head Part Number	12-Point Bolt Part Number	Qty/Pkg	Shipping Weight lbs (kg)
1 ½ in.	Clear hole flanges	N/A	FB0133C**	25	0.5 (0.2)
	Tapped hole flanges	N/A	FB0133T**	25	0.5 (0.2)
2 ½ in.	Clear hole flanges	FB0275C06	FB0275C12	25	1.0 (0.5)
	Tapped hole flanges	FB0275T06	FB0275T12	25	1.0 (0.5)
2 ¾ in.	Clear hole flanges	FB0275C06	FB0275C12	25	1.0 (0.5)
	Tapped hole flanges	FB0275T06	FB0275T12	25	1.0 (0.5)
3 ¾ in.	Clear hole flanges	FB0338C06	FB0338C12	25	2.0 (0.9)
	Tapped hole flanges	FB0450T06	FB0450T12	25	2.0 (0.9)
4 ½ in.	Clear hole flanges	FB0450C06	FB0450C12	25	2.0 (0.9)
	Tapped hole flanges	FB0450T06	FB0450T12	25	2.0 (0.9)
4 ¾ in.	Clear hole flanges non rot.	FB0450C06	FB0450C12	25	1.5 (0.7)
	Clear hole flanges rot.	FB0600C06	FB0600C12	25	1.5 (0.7)
	Tapped hole flanges	FB0450T06	FB0450T12	25	1.5 (0.7)

* Includes nuts, washers, and bolts

** Only available in socket head

Accessories – Bolt Sets for Reducing Flanges

Flange Size	Part Number	Small Flange	Large Flange	Weight lbs (kg)
2 ¾ in. to 1 ½ in.	FB02750133CR12	6 bolts/washers	6 bolts/washers	2.0 (0.9)
3 ¾ in. to 2 ¾ in.	FB03380275CR12	6 bolts	8 bolts	3.0 (1.4)
4 ½ in. to 2 ¾ in.	FB04500275CR12	6 bolts/washers	8 bolts/washers/nuts	3.0 (1.4)
6 in. to 2 ¾ in.	FB06000275CR12	6 bolts/washers	16 bolts/washers/nuts	4.0 (1.8)
6 in. to 3 ¾ in.	FB06000338CR12	8 bolts/washers	16 bolts/washers/nuts	4.0 (1.8)
6 in. to 4 ½ in.	FB06000450CR12	8 bolts/washers	16 bolts/washers/nuts	4.0 (1.8)
8 in. to 2 ¾ in.	FB08000275CR12	6 bolts/washers	20 bolts/washers/nuts	4.0 (1.8)
8 in. to 4 ½ in.	FB08000450CR12	8 bolts/washers	20 bolts/washers/nuts	4.0 (1.8)
10 in. to 2 ¾ in.	FB10000275CR12	6 bolts/washers	24 bolts/washers/nuts	5.0 (2.3)
10 in. to 8 in.	FB10000800CR12	20 bolts/washers	24 bolts/washers/nuts	5.0 (2.3)

NOTE • Reducing flange bolt sets include sockets, 6 point and 12 point bolts dependent on size:
1.33 bolts are socket keyed (SH), 6.75 in. and 13.25 in. bolts are hex head.
All other sizes are 12 point heads.

CONFLAT FITTINGS

▶ Reducing Nipples - 304 Stainless Steel

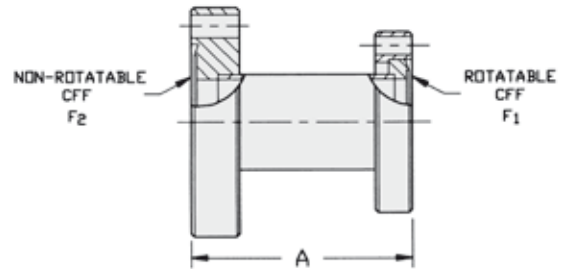
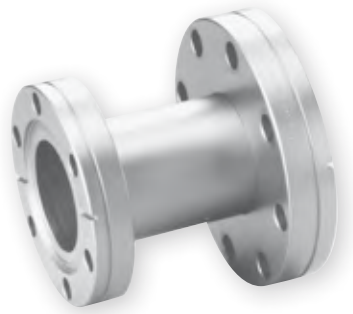

Ordering Information

Flange Size	Part Number	Length A in. (mm)	Non-Rotatable F2	Rotatable F1	Shipping Weight lbs (kg)
2 3/4 in.	FA02750133	2.50 (63.50)	2 3/4	1 1/8	1.5 (0.7)
	FA02750212	2.75 (69.85)	2 3/4	2 1/8	1.5 (0.7)
4 1/2 in.	FA04500133	2.50 (63.50)	4 1/2	1 1/8	4.0 (1.8)
	FA04500275	2.50 (63.50)	4 1/2	2 3/4	4.0 (1.8)
	FA04500275L	3.00 (76.20)	4 1/2	2 3/4	4.0 (1.8)
6 in.	FA06000133	2.50 (63.50)	6	1 1/8	8.0 (3.6)
	FA06000275	3.25 (82.55)	6	2 3/4	8.0 (3.6)
	FA06000450	2.50 (63.50)	6	4 1/2	10.0 (4.5)
8 in.	FA08000275L	4.00 (101.60)	8	2 3/4	14.0 (6.3)
	FA08000450	2.50 (63.50)	8	4 1/2	16.0 (7.2)
	FA08000600	2.50 (63.50)	8	6	18.0 (8.1)
	FA08000600L	4.50 (114.30)	8	6	16.0 (7.2)
10 in.	FA10000800	4.75 (120.65)	10	8	20.0 (9.0)

NOTE • Clear Hole ConFlat Flange

VACUUM COMPONENTS

▶ Half Nipples

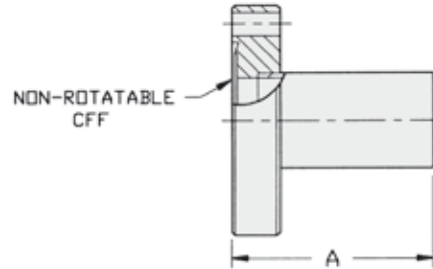

Ordering Information – Half Nipples, Standard Tube Size

Tube Size	Part Number	Flange OD	Overall Length A in. (mm)	Tube OD in. (mm)	Tube ID in. (mm)	Shipping Weight lbs (kg)
¼ in.	FNH0075	1 ½	1.50 (38.10)	0.75 (19.05)	0.68 (17.27)	0.8 (0.3)
1 in.	FNH01000275	2 ¾	2.46 (62.48)	1.00 (25.40)	0.87 (19.81)	1.0 (0.5)
1 ½ in.	FNH0150S	2 ¾	2.46 (62.48)	1.50 (38.10)	1.37 (34.80)	1.0 (0.5)
	FNH0150	2 ¾	4.71 (119.63)	1.50 (38.10)	1.37 (34.80)	1.0 (0.5)
2 in.	FNH0200	3 ⅜	3.21 (81.53)	2.00 (50.80)	1.87 (47.50)	2.0 (0.9)
2 ½ in.	FNH0250S	4 ½	3.38 (85.85)	2.50 (63.50)	2.37 (60.20)	6.0 (2.7)
	FNH0250	4 ½	4.12 (104.65)	2.50 (63.50)	2.37 (60.20)	6.0 (2.7)
3 in.	FNH0300S	4 ⅝	3.53 (89.66)	3.00 (76.20)	2.87 (72.90)	7.0 (3.2)
4 in.	FNH0400S	6	4.32 (109.73)	4.00 (101.60)	3.83 (97.28)	11.0 (4.9)
6 in.	FNH0600S	8	5.50 (139.70)	6.00 (152.40)	5.83 (148.08)	19.0 (8.6)
	FNH0600	8	6.56 (166.62)	6.00 (152.40)	5.83 (148.08)	19.0 (8.6)
8 in.	FNH0800	10	8.00 (203.20)	8.00 (203.20)	7.83 (198.88)	26.0 (11.8)

Ordering Information – Half Nipples, Rotatable Flanges

Tube Size	Part Number	Flange OD	Overall Length A in. (mm)	Tube OD in. (mm)	Tube ID in. (mm)	Shipping Weight lbs (kg)
1 ½ in.	FNH0150R	2 ¾	2.36 (60.00)	1.50 (38.10)	1.37 (34.80)	1.0 (0.5)

NOTE • Clear Hole ConFlat Flange

CONFLAT FITTINGS

► Nipples

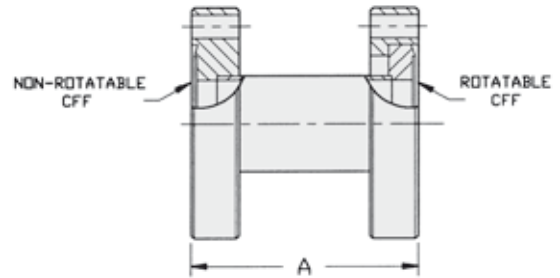
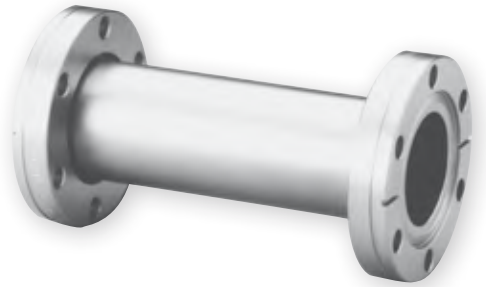

Ordering Information

Tube Size	Part Number	Flange OD	Overall Length A in. (mm)	Tube OD in. (mm)	Tube ID in. (mm)	Shipping Weight lbs (kg)
¼ in.	FNF0075	1 ½	3.00 (76.20)	0.75 (19.05)	0.62 (17.27)	1.5 (0.7)
1 ½ in.	FNF0150	2 ¾	4.93 (125.22)	1.50 (38.10)	1.37 (34.80)	2.0 (0.9)
2 in.	FNF0200	3 ¾	6.43 (163.32)	2.00 (50.80)	1.87 (47.50)	4.0 (1.8)
2 ½ in.	FNF0250	4 ½	8.25 (209.55)	2.50 (63.50)	2.37 (60.20)	8.0 (3.6)
	FNF0250S	4 ½	6.76 (171.70)	2.50 (63.50)	2.37 (60.20)	8.0 (3.6)
4 in.	FNF0400	6	10.63 (270.00)	4.00 (101.60)	3.83 (97.28)	15.0 (6.8)
	FNF0400S	6	8.64 (219.46)	4.00 (101.60)	3.83 (97.28)	13.0 (5.9)
6 in.	FNF0600	8	13.13 (333.50)	6.00 (152.40)	5.83 (148.08)	24.0 (10.8)
	FNF0600S	8	11.00 (279.40)	6.00 (152.40)	5.83 (148.08)	24.0 (10.8)
8 in.	FNF0800	10	16.00 (406.40)	8.00 (203.20)	7.83 (198.88)	30.0 (13.5)

NOTE • Clear Hole ConFlat Flange

VACUUM COMPONENTS

► Elbows (90°)

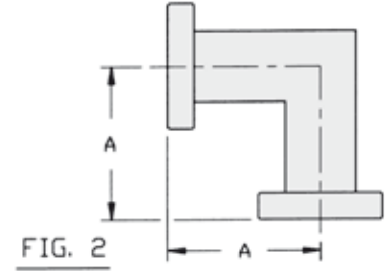
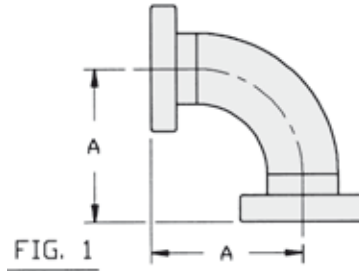

Ordering Information

Nominal Tube Size	Part Number	Flange Size	Fig. Number	Dimension A in. (mm)	Shipping Weight lbs (kg)
¼ in.	FE0075	1½	1	1.50 (38.10)	1.5 (0.7)
1½ in.	FE0150	2¾	1	2.46 (62.48)	2.0 (0.9)
2½ in.	FE0250	4½	2	4.13 (104.90)	8.0 (3.6)
4 in.	FE0400	6	2	5.31 (134.87)	15.0 (6.8)
6 in.	FE0600	8	2	6.56 (166.62)	24.0 (10.8)

NOTE • All flanges are rotatable
• Clear Hole ConFlat Flange

CONFLAT FITTINGS

▶ Tees

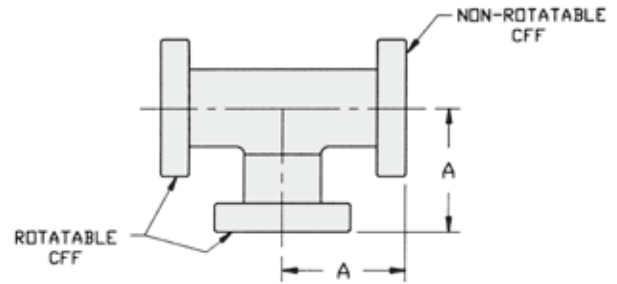

Ordering Information

Nominal Tube Size	Part Number	Flange Size	Dimension A in. (mm)	Shipping Weight lbs (kg)
¾ in.	FT0075	1 ⅓	1.50 (38.10)	2.0 (0.9)
1 ½ in.	FT0150	2 ¾	2.46 (62.50)	4.0 (1.8)
2 ½ in.	FT0250	4 ½	4.13 (104.90)	11.0 (4.9)
4 in.	FT0400	6	5.31 (134.87)	21.0 (9.5)
6 in.	FT0600	8	6.56 (166.62)	34.0 (15.4)

NOTE • Clear Hole ConFlat Flange

▶ Crosses (4-Way)

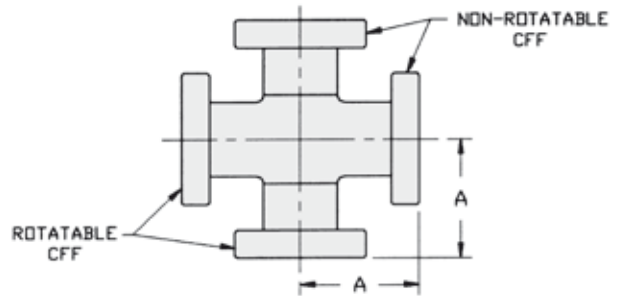
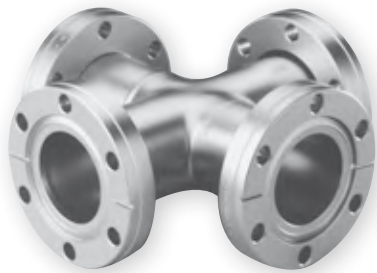

Ordering Information

Nominal Tube Size	Part Number	Flange Size	Dimension A in. (mm)	Shipping Weight lbs (kg)
¾ in.	FC0075	1 ⅓	1.50 (38.10)	2.3 (1.0)
1 ½ in.	FC0150	2 ¾	2.46 (62.50)	4.0 (1.8)
2 in.	FC0200	3 ¾	3.21 (81.53)	9.0 (4.1)
2 ½ in.	FC0250	4 ½	4.13 (104.90)	14.0 (6.3)
4 in.	FC0400	6	5.31 (134.87)	26.0 (11.8)
6 in.	FC0600	8	6.56 (166.62)	44.0 (19.9)

NOTE • Clear Hole ConFlat Flange

VACUUM COMPONENTS

► Flexible Couplings (Non-Braided)

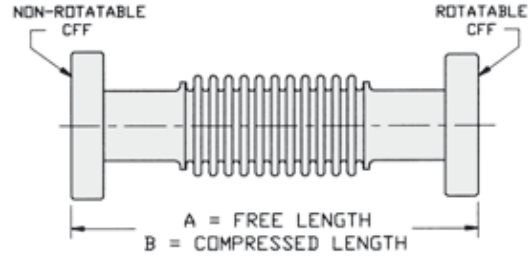
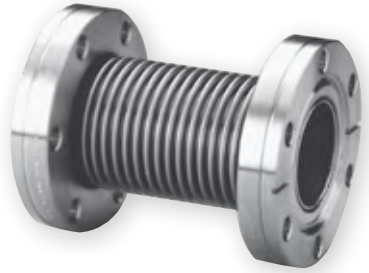

Specifications

- Vacuum-compatible stainless steel
- Sizes ¼ in. – 6 in.
- Full penetration vacuum welds

Ordering Information

Nominal O.D.	Part Number	Flange Size	Length Free A in. (mm)	Length Compressed B in. (mm)	Static Bend Radius in. (mm)	Bellows Wall Thickness in.	Nominal ID in. (mm)	Shipping Weight lbs (kg)
¾ in.	FL00750300	1 ½	3.0 (76)	2.8 (71)	0.8 (20)	0.008	0.5 (12.7)	1.5 (0.7)
	FL00750600	1 ½	6.0 (152)	5.5 (140)	0.8 (20)	0.008	0.5 (12.7)	1.5 (0.7)
	FL00751000	1 ½	10.0 (254)	9.1 (231)	0.8 (20)	0.008	0.5 (12.7)	2.0 (0.9)
	FL00751200	1 ½	12.0 (305)	10.9 (271)	0.8 (20)	0.008	0.5 (12.7)	2.0 (0.9)
	FL00751800	1 ½	18.0 (457)	16.3 (414)	0.8 (20)	0.008	0.5 (12.7)	3.0 (1.4)
	FL00752000	1 ½	20.0 (508)	18.1 (460)	0.8 (20)	0.008	0.5 (12.7)	4.0 (1.8)
	FL00752400	1 ½	24.0 (610)	21.7 (551)	0.8 (20)	0.008	0.5 (12.7)	4.0 (1.8)
	FL00753600	1 ½	36.0 (914)	32.5 (826)	0.8 (20)	0.008	0.5 (12.7)	5.0 (2.3)
	FL00754800	1 ½	48.0 (1219)	43.3 (1100)	0.8 (20)	0.008	0.5 (12.7)	5.0 (2.3)
1 ½ in.	FL01500334	2 ¾	3.3 (85)	3.2 (80)	6.0 (152)	0.006	1.5 (38.1)	2.0 (0.9)
	FL01500400	2 ¾	4.0 (102)	3.7 (95)	6.0 (152)	0.006	1.5 (38.1)	2.0 (0.9)
	FL01501200	2 ¾	12.0 (305)	10.9 (278)	2.2 (56)	0.010	1.5 (38.1)	3.0 (1.4)
	FL01501800	2 ¾	18.0 (457)	16.3 (415)	2.2 (56)	0.010	1.5 (38.1)	4.0 (1.8)
	FL01502000	2 ¾	20.0 (508)	18.1 (461)	2.2 (56)	0.010	1.5 (38.1)	4.0 (1.8)
	FL01502400	2 ¾	24.0 (610)	21.7 (552)	2.3 (56)	0.010	1.5 (38.1)	5.0 (2.3)
	FL01503600	2 ¾	36.0 (914)	32.5 (827)	2.2 (56)	0.010	1.5 (38.1)	6.0 (2.7)
	FL01504800	2 ¾	48.0 (1220)	43.3 (1101)	2.2 (56)	0.010	1.5 (38.1)	6.0 (2.7)
	2 in.	FL02000600	3 ⅞	6.0 (152)	5.6 (142)	7.5 (191)	0.006	2.0 (50.8)
FL02001200		3 ⅞	12.0 (305)	11.0 (279)	2.6 (66)	0.012	2.0 (50.8)	5.0 (2.3)
2 ½ in.	FL02500625	4 ½	6.3 (159)	5.9 (149)	10.0 (254)	0.006	2.5 (63.5)	7.0 (3.2)
	FL02501200	4 ½	12.0 (305)	11.0 (280)	3.2 (81)	0.012	2.5 (63.5)	8.0 (3.6)
	FL02502400	4 ½	24.0 (610)	21.8 (554)	3.2 (81)	0.012	2.5 (63.5)	9.0 (4.1)
	FL02503600	4 ½	36.0 (914)	32.6 (829)	3.2 (81)	0.012	2.5 (63.5)	10.0 (4.5)
4 in.	FL04000763	6	7.6 (194)	7.1 (180)	19.0 (483)	0.010	4.0 (101.6)	14.0 (6.4)

NOTE • Clear Hole ConFlat Flange

CONFLAT FITTINGS

► Flexible Couplings (Braided)

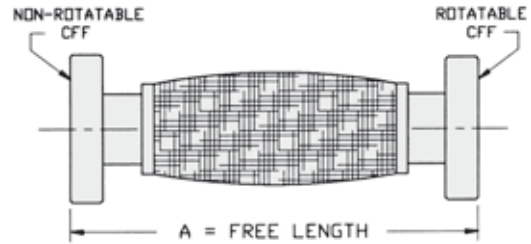
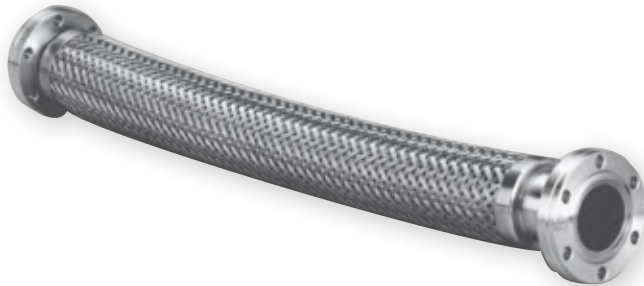

Specifications

- Vacuum-compatible stainless steel
- Sizes ¼ in. – 6 in.
- Full penetration vacuum welds

Ordering Information

Nominal O.D.	Part Number	Flange Size	Length Free A in. (mm)	Static Bend Radius in. (mm)	Bellows Wall Thickness in.	Nominal ID in. (mm)	Shipping Weight lbs (kg)
¾ in.	FLB00751200	1 ⅓	12.0 (305)	2.1 (53)	0.008	0.75 (19.1)	2.0 (0.9)
	FLB00751800	1 ⅓	18.0 (457)	2.1 (53)	0.008	0.75 (19.1)	3.0 (1.4)
	FLB00753600	1 ⅓	36.0 (914)	2.1 (53)	0.008	0.75 (19.1)	5.0 (2.3)
	FLB00754800	1 ⅓	48.0 (1219)	2.1 (53)	0.008	0.75 (19.1)	5.0 (2.3)
1 ½ in.	FLB01500600	2 ¾	6.0 (152)	3.9 (99)	0.010	1.50 (38.1)	2.0 (0.9)
	FLB01501200	2 ¾	12.0 (305)	3.9 (99)	0.010	1.50 (38.1)	3.0 (1.4)
	FLB01501875	2 ¾	18.8 (478)	3.9 (99)	0.010	1.50 (38.1)	4.0 (1.8)
	FLB01502400	2 ¾	24.0 (610)	3.9 (99)	0.010	1.50 (38.1)	5.0 (2.3)
	FLB01503600	2 ¾	36.0 (914)	3.9 (99)	0.010	1.50 (38.1)	6.0 (2.7)
	FLB01504800	2 ¾	48.0 (1219)	3.9 (99)	0.010	1.50 (38.1)	6.0 (2.7)
2 ½ in.	FLB02502400	4 ½	24.0 (610)	5.9 (150)	0.012	2.50 (63.5)	9.0 (4.1)
	FLB02503600	4 ½	36.0 (914)	5.9 (150)	0.012	2.50 (63.5)	10.0 (4.5)

NOTE • Clear Hole ConFlat Flange

VACUUM COMPONENTS

► CFF to KF Adapters

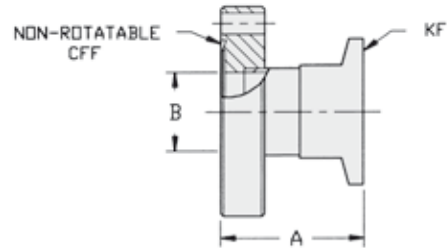

Ordering Information

CFF Size	Part Number	CFF OD	KF Flange		Overall Length A in. (mm)	Tube ID B in. (mm)	Weight lbs (kg)
			NW	Size OD			
1 1/8 in.	FA0133NW16S	1.33	NW16	1.18	1.57 (39.88)	0.68 (17.27)	1.0 (0.5)
	FA0133NW16	1.33	NW16	1.18	2.00 (50.80)	0.68 (17.27)	1.0 (0.5)
	FA0133NW16L	1.33	NW16	1.18	2.07 (52.70)	0.68 (17.27)	1.0 (0.5)
	FA0133NW25	1.33	NW25	1.57	2.00 (50.80)	0.68 (17.27)	1.5 (0.7)
	FA0133NW40	1.33	NW40	2.16	1.57 (39.88)	0.68 (17.27)	1.5 (0.7)
2 3/4 in.	FA0275NW16S	2.73	NW16	1.18	1.78 (45.21)	0.68 (17.27)	1.5 (0.7)
	FA0275NW16	2.73	NW16	1.18	2.00 (50.80)	0.68 (17.27)	1.5 (0.7)
	FA0275NW16L	2.73	NW16	1.18	2.36 (59.94)	0.68 (17.27)	1.5 (0.7)
	FA0275NW25S	2.73	NW25	1.57	1.78 (45.21)	0.87 (22.10)	1.5 (0.7)
	FA0275NW25	2.73	NW25	1.57	2.00 (50.80)	0.87 (22.10)	1.5 (0.7)
	FA0275NW25L	2.73	NW25	1.57	2.36 (59.94)	0.87 (22.10)	1.5 (0.7)
	FA0275NW40S	2.73	NW40	2.16	1.78 (45.21)	1.37 (34.80)	2.0 (0.9)
	FA0275NW40	2.73	NW40	2.16	2.00 (50.80)	1.37 (34.80)	2.0 (0.9)
	FA0275NW40L	2.73	NW40	2.16	2.55 (64.77)	1.37 (34.80)	2.0 (0.9)
4 1/2 in.	FA0450NW40	4.47	NW40	2.16	2.00 (50.80)	1.37 (34.80)	3.0 (1.4)
	FA0450NW50L	4.47	NW50	2.95	2.00 (50.80)	1.87 (47.50)	3.0 (1.4)
	FA0450NW50	4.47	NW50	2.95	1.95 (49.53)	1.87 (34.80)	3.0 (1.4)

Accessories

Size	Description	Part Number	Qty/Pkg	Shipping Weight lbs (kg)
NW16	Viton centering ring	KC16SV	1	0.5 (0.2)
NW25	Viton centering ring	KC25SV	1	0.5 (0.2)
NW40	Viton centering ring	KC40SV	1	0.5 (0.2)
NW50	Viton centering ring	KC50SV	1	0.5 (0.2)
NW16	KF clamp	KQ16AR	1	0.5 (0.2)
NW25	KF clamp	KQ25AR	1	0.5 (0.2)
NW40	KF clamp	KQ40AR	1	1.0 (0.5)
NW50	KF clamp	KQ50AR	1	1.0 (0.5)

NOTE • Clear Hole ConFlat Flange

CONFLAT FITTINGS

► Adapters: ConFlat to Swagelok



Ordering Information

Flange Size	Tube Size	Part Number	Length in. (mm)	Shipping Weight lbs (kg)
1 1/8 in.	1/4 in.	FASW0250133	1.37 (34.8)	0.5 (0.22)
2 3/4 in.	1/4 in.	FASW0250275	1.53 (38.9)	1.0 (0.45)
1 1/8 in.	3/8 in.	FASW0375133	1.66 (42.2)	0.5 (0.22)
2 3/4 in.	3/8 in.	FASW0375275	1.69 (42.9)	1.0 (0.45)
2 3/4 in.	1/2 in.	FASW0500275	1.83 (46.5)	1.0 (0.45)
2 3/4 in.	3/4 in.	FASW0750275	2.20 (55.9)	1.0 (0.45)

NOTE • Clear Hole ConFlat Flange

VACUUM COMPONENTS

▶ Adapters: ConFlat to VCR - Male & Female



Ordering Information

Flange Size	Tube Size	Part Number	Length in. (mm)	Shipping Weight lbs (kg)
Male				
1 1/8 in.	1/4 in.	FAVM0250133	1.36 (34.5)	0.5 (0.22)
2 3/4 in.	1/4 in.	FAVM0250275	1.52 (38.6)	1.0 (0.45)
1 1/8 in.	1/2 in.	FAVM0500133	1.55 (39.4)	0.5 (0.22)
2 3/4 in.	1/2 in.	FAVM0500275	1.71 (43.4)	1.0 (0.45)
2 3/4 in.	1 in.	FAVM1000275	2.43 (61.7)	1.0 (0.45)
Female				
1 1/8 in.	1/4 in.	FAVF0250133	1.36 (34.5)	0.5 (0.22)
2 3/4 in.	1/4 in.	FAVF0250275	1.52 (38.6)	1.0 (0.45)
2 3/4 in.	3/8 in.	FAVF0375275	1.71 (43.4)	1.0 (0.45)
1 1/8 in.	1/2 in.	FAVF0500133	1.55 (39.4)	0.5 (0.22)
2 3/4 in.	1/2 in.	FAVF0500275	1.71 (43.4)	1.0 (0.45)
2 3/4 in.	1 in.	FAVF1000275	2.43 (61.7)	1.0 (0.45)

NOTE • Clear Hole ConFlat Flange

CONFLAT FITTINGS

► UHV Compression Ports

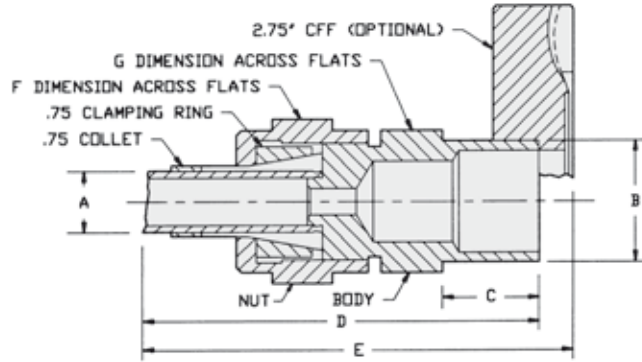

	A	B	C	D	E	F	G
3/8" assy	0.75 (19.1)	1.00 (24.5)	0.66 (16.7)	2.63 (66.8)	3.00 (76.2)	1.38 (35.0)	1.19 (30.2)
3/8" assy	0.38 (9.7)	0.75 (19.1)	0.63 (16.0)	2.31 (55.7)	2.53 (64.3)	0.88 (22.4)	0.77 (19.6)
1/2" assy	0.50 (12.7)	0.75 (19.1)	0.65 (16.5)	2.63 (66.8)	2.81 (71.4)	1.13 (28.7)	1.00 (25.4)

Dimensions: inches (millimeters)

Specifications

- Vacuum range: 10^{-11} Torr (mbar)
- Bakeout Temperature: 500 °C

Ordering Information

Description	Part Number	Shipping Weight lbs (kg)
Compression Port with Felpro Lubricant		
3/8 in. (9.9 mm) port on 2.75 (NW35) ConFlat	FCP0038UHV	3.0 (1.3)
1/2 in. (12.7 mm) port	CP0050UHV	2.0 (0.9)
1/2 in. (12.7 mm) port on 2.75 (NW35) ConFlat	FCP0050UHV	3.0 (1.3)
3/4 in. (19 mm) port	CP0075UHV	2.0 (0.9)
3/4 in. (19 mm) port on 2.75 (NW35) ConFlat	FCP0075UHV	3.0 (1.3)
Combination Compression Port Body and Nut		
3/4 in. (19 mm) Assembly		
Includes collet, clamping ring, and Felpro lubricant	CP0075UHVA	1.0 (0.5)
Compression Port Rebuild Kits		
3/8 in. (9.9 mm) ports	CP0038RK	1.0 (0.5)
1/2 in. (12.7 mm) ports	CP0050RK	1.0 (0.5)
OFHC Copper Tubulations 6 in. (152.4 mm) Long		
3/8 in. (9.9 mm) OD, .032 wall thickness	CP0038CT	1.0 (0.5)
1/2 in. (12.7 mm) OD, .035 wall thickness	CP0050CT	1.0 (0.5)
3/4 in. (19 mm) OD, .035 wall thickness	CP0075CT	2.0 (0.9)
OFHC Copper Adapters		
3/8 in. (9.9 mm) port adapter with 1.33 (NW16) ConFlat gasket/package of 4	CP00380133CA	1.5 (0.7)
3/8 in. (9.9 mm) port adapter with 2.75 (NW35) ConFlat gasket/package of 4	CP00380275CA	1.5 (0.7)

VACUUM COMPONENTS

► ConFlat to Compression Port Adapters

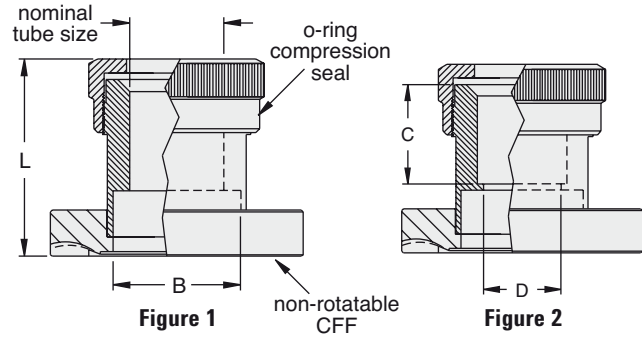

Specifications

- Stainless steel
- Viton o-ring
- Use with glass gauges or standard metal tubing
- Hand-tightened compression fitting

Ordering Information

Nominal Tube Size	Part Number	Bore ID B in. (mm)	Length L in. (mm)	Flange Size	ID C in. (mm)	Tube Stop D in. (mm)	Fig. Number	Weight lbs (kg)
3/16 in.	FCP01900275	0.63 (16.00)	1.71 (43.43)	2.75	—	—	1	2.0 (0.9)
1/4 in.	FCP02500133	0.63 (16.00)	1.67 (42.67)	1.33	—	—	1	2.0 (0.9)
	FCP02500275	0.63 (16.00)	1.71 (43.43)	2.75	—	—	1	2.0 (0.9)
3/8 in.	FCP03750133	0.63 (16.00)	1.67 (42.67)	1.33	—	—	1	2.0 (0.9)
	FCP03750275	0.63 (16.00)	1.71 (43.43)	2.75	—	—	1	2.0 (0.9)
1/2 in.	FCP05000133	0.63 (16.00)	1.67 (42.67)	1.33	—	—	1	2.0 (0.9)
	FCP05000275	0.63 (16.00)	1.71 (43.43)	2.75	—	—	1	2.0 (0.9)
3/4 in.	FCP07500275	1.38 (35.05)	2.02 (51.31)	2.75	0.63 (16.00)	1.13 (28.70)	2	2.0 (0.9)
1 in.	FCP10000275	1.38 (35.05)	2.08 (52.83)	2.75	0.88 (22.35)	1.13 (28.70)	2	2.0 (0.9)
1 1/8 in.	FCP11250275	1.38 (35.05)	2.08 (52.83)	2.75	—	—	1	2.0 (0.9)

NOTE • Clear Hole ConFlat Flange

CONFLAT FITTINGS

► O-Ring Sealed Vacuum Compression Ports and Blank-offs

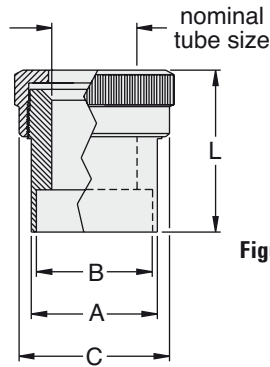

Figure 1

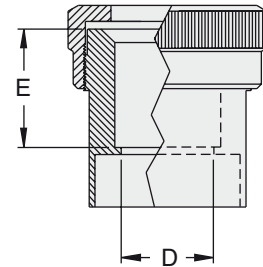

Figure 2

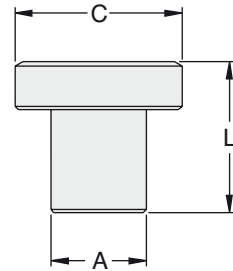

Figure 3

Ordering Information

Nominal Tube Size	Part Number	Fig. Number	Body OD		Bore ID		OD		Length		I.D.		Tube Stop		Weight lbs (kg)
			A in. (mm)	B in. (mm)	C in. (mm)	L in. (mm)	D in. (mm)	E in. (mm)							
¼ in.	CP0250S	1	0.75 (19.05)	0.63 (16.00)	1.14 (28.96)	1.50 (38.10)	–	–	–	–	–	–	–	–	1.0 (0.5)
⅝ in.	CP0312S	1	0.75 (19.05)	0.63 (16.00)	1.14 (28.96)	1.50 (38.10)	–	–	–	–	–	–	–	–	1.0 (0.5)
¾ in.	CP0375S	1	0.75 (19.05)	0.63 (16.00)	1.14 (28.96)	1.50 (38.10)	–	–	–	–	–	–	–	–	1.0 (0.5)
½ in.	CP0500S	1	0.75 (19.05)	0.63 (16.00)	1.14 (28.96)	1.50 (38.10)	–	–	–	–	–	–	–	–	1.0 (0.5)
⅝ in.	CP0625S	1	0.75 (19.05)	0.63 (16.00)	1.14 (28.96)	1.50 (38.10)	–	–	–	–	–	–	–	–	1.0 (0.5)
¾ in.	CP0750S	1	1.50 (38.10)	1.38 (35.05)	1.89 (48.01)	1.88 (47.75)	–	–	–	–	–	–	–	–	1.0 (0.5)
1 in.	CP1000S	2	1.50 (38.10)	1.38 (35.05)	1.89 (48.01)	1.88 (47.75)	0.88 (22.35)	1.13 (28.70)	–	–	–	–	–	–	1.0 (0.5)
1⅝ in.	CP1125S	1	1.50 (38.10)	1.38 (35.05)	1.89 (48.01)	1.88 (47.75)	–	–	–	–	–	–	–	–	1.0 (0.5)
1¼ in.	CP1250S	1	1.50 (38.10)	1.38 (35.05)	1.89 (48.01)	1.88 (47.75)	–	–	–	–	–	–	–	–	1.0 (0.5)

VACUUM COMPONENTS

► Zero-Length Glass Viewports

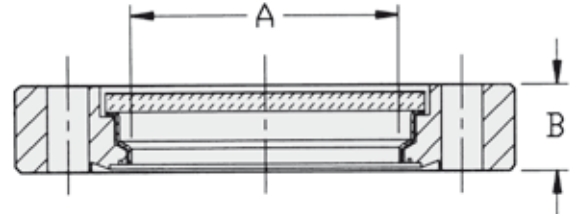

Specifications

- Transmission Range: 0.32 to 2.7 microns (approx.)
- Vacuum Range: To below 10^{-11} Torr (mbar)
- Viewport Type: 7056 Glass
- Bakeout Temperature: 400 °C

Ordering Information

Description	ConFlat Size	Part Number	Nominal Port Diameter in. (mm)	A in. (mm)	B in. (mm)	Weight lbs (kg)
¾ in. (14 mm) Viewport	1.33 in. (NW16)	FVG0075	0.75 (19.05)	0.63 (16)	0.29 (7.37)	1.0 (0.5)
1½ in. (36 mm) Viewport	2.75 in. (NW35)	FVG0150	1.50 (38.10)	1.50 (38)	0.50 (12.70)	2.0 (0.9)
2½ in. (63.5 mm) Viewport	4.50 in. (NW63)	FVG0250	2.50 (63.50)	2.48 (63)	0.68 (17.40)	5.0 (2.3)
4 in. (98 mm) Viewport	6 in. (NW100)	FVG0400	4.00 (101.60)	3.50 (89)	0.78 (19.90)	6.0 (2.7)
6 in. (137 mm) Viewport	8 in. (NW150)	FVG0600	6.00 (152.40)	5.35 (136)	0.92 (23.37)	9.0 (4.0)

NOTE • Clear Hole ConFlat Flange

CONFLAT FITTINGS

► Sapphire Viewports - Zero Length

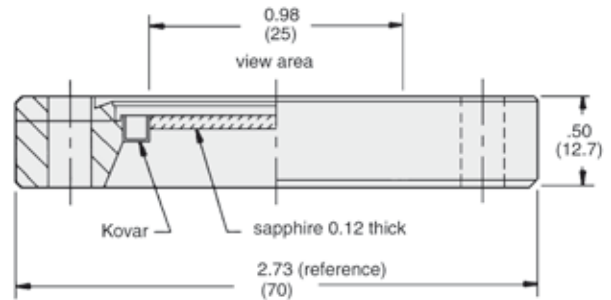

Dimensions: inches (millimeters)

Specifications

- Transmission Range: 0.25 to 5.5 microns (approx.)
- Vacuum Range: To below 10^{-11} Torr (mbar)
- Bakeout Temperature: 450 °C

Ordering Information

Description	Part Number	Weight lbs (kg)
1 in. (25.4 mm) Zero Length Sapphire/Kovar Viewport on 2.75 (NW35) ConFlat flange	FVS0100	2.0 (0.9)

NOTE • Clear Hole ConFlat Flange

► Sapphire Viewports - Standard Length

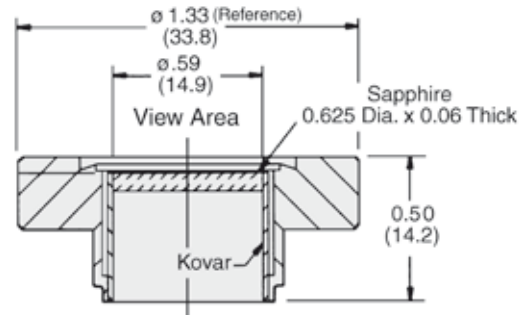

Dimensions: inches (millimeters)

Specifications

- Transmission Range: .25 to 5.5 microns (approx.)
- Vacuum Range: To below 10^{-11} Torr (mbar)
- Bakeout Temperature: 450 °C

Ordering Information

Description	Part Number	Shipping Weight lbs (kg)
5/8 in. (15.8 mm) Standard Length Sapphire/Kovar Viewport on 1.33 (NW13) ConFlat flange	FVS0062	1.0 (0.5)

NOTE • Clear Hole ConFlat Flange

VACUUM COMPONENTS

▶ Glass Adapters with Bellows

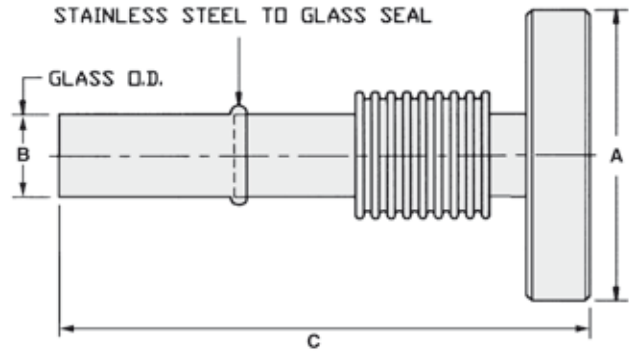

Specifications

- Vacuum Range: To below 10^{-11} Torr (mbar)
- Bakeout Temperature: 400 °C
- Pyrex 7740 Glass

Ordering Information

Description	Part Number	A in. (mm)	B in. (mm) (Reference)	C in. (mm)	Shipping Weight lbs (kg)
6 mm OD Glass Adapter					
with bellows and mini ConFlat flange	FGAB7	1.33 (34.0)	0.24 (6.0)	6.69 (170.0)	1.0 (0.5)
10 mm OD Glass Adapter					
with bellows and mini ConFlat flange	FGAB10	1.33 (34.0)	0.39 (10.0)	5.50 (140.0)	1.0 (0.5)
13 mm OD Glass Adapter					
with bellows and mini ConFlat flange	FGAB13	1.33 (34.0)	0.51 (13.0)	6.69 (170.0)	2.0 (0.9)
19 mm OD Glass Adapter					
with bellows and 2.75 ConFlat flange	FGAB19	2.75 (70.0)	0.75 (19.0)	7.48 (190.0)	2.0 (0.9)

NOTE • Clear Hole ConFlat Flange

CONFLAT FITTINGS

► Glass Adapters

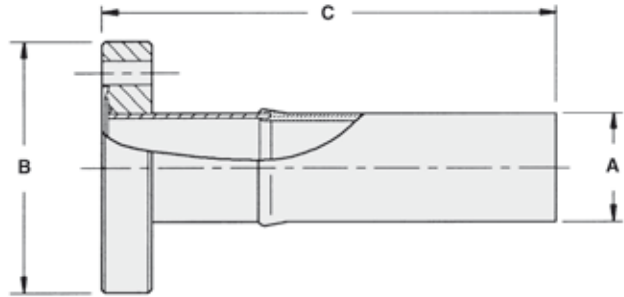

Specifications

- Vacuum Range: To below 10^{-11} Torr (mbar)
- Bakeout Temperature: 400 °C
- Glass Type: see ordering information table

Ordering Information

Description	Part Number	A in. (mm) Nom.	B in. (mm) (Reference)	C in. (mm)	Weight lbs (kg)
¼ in. Kovar to Pyrex Glass Adapter on 1.33 (NW16) ConFlat	FGA0025KP	0.24 (6.0)	1.33 (34.0)	3.94 (100.0)	1.5 (0.7)
¼ in. Stainless Steel to Pyrex Glass Adapter on 1.33 (NW16) ConFlat	FGA0025SP	0.24 (6.0)	1.33 (34.0)	4.88 (124.0)	1.5 (0.7)
½ in. Kovar to Pyrex Glass Adapter on 1.33 (NW16) ConFlat	FGA0050KP	0.51 (13.0)	1.33 (34.0)	3.94 (100.0)	1.5 (0.7)
½ in. Stainless Steel to Pyrex Glass Adapter on 1.33 (NW16) ConFlat	FGA0050SP	0.51 (13.0)	1.33 (34.0)	4.88 (124.0)	1.5 (0.7)
¾ in. Kovar to Pyrex Glass Adapter on 1.33 (NW16) ConFlat	FGA0075KP	0.75 (19.0)	1.33 (34.0)	5.38 (137.0)	1.5 (0.7)
¾ in. Stainless Steel to Pyrex Glass Adapter on 1.33 (NW16) ConFlat	FGA0075SP	0.75 (19.0)	1.33 (34.0)	4.88 (124.0)	1.5 (0.7)
1 in. Kovar to Pyrex Glass Adapter on 2.75 (NW35) ConFlat	FGA0100KP	1.00 (25.0)	2.75 (70.0)	3.94 (100.0)	3.0 (1.4)
1 in. Stainless Steel to Pyrex Glass Adapter on 2.75 (NW35) ConFlat	FGA0100SP	1.00 (25.0)	2.75 (70.0)	4.88 (124.0)	3.0 (1.4)
1½ in. Kovar to Pyrex Glass Adapter on 2.75 (NW35) ConFlat	FGA0150KP	1.57 (40.0)	2.75 (70.0)	3.94 (100.0)	4.0 (1.8)
1½ in. Stainless Steel to Pyrex Glass Adapter on 2.75 (NW35) ConFlat	FGA0150SP	1.50 (38.0)	2.75 (70.0)	4.88 (124.0)	4.0 (1.8)
2½ in. Stainless Steel to Pyrex Glass Adapter on 4.5 (NW63) ConFlat	FGA0250SP	2.50 (64.0)	4.50 (114.0)	5.33 (137.0)	5.0 (2.3)

NOTE • Clear Hole ConFlat Flange

KLAMPS FLANGES & FITTINGS

Agilent’s introduction of its extensive offering in vacuum flanges and fittings features an intuitive part numbering format. These part numbering format allows the customer to identify the product by the characters contained within the part number.

Depending on the product, the number and format of the characters in the part number will vary. Please see the examples below:

KF Flange Example

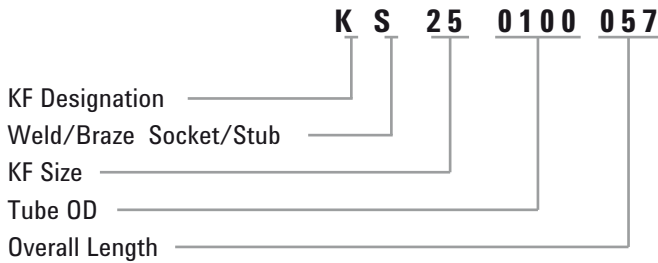

KF25 to 40 Conical Reducer Example

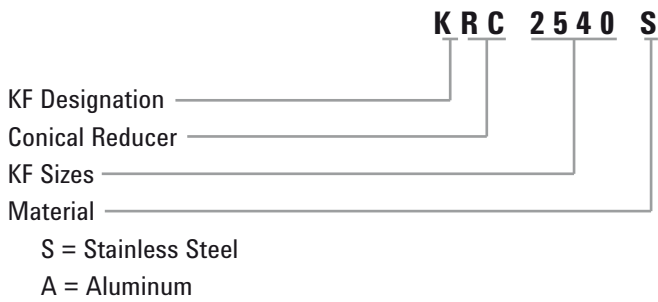

VACUUM COMPONENTS

Klump-Flanges

Designed in accordance with ISO standards the Agilent KF flange can be used in a variety of applications from atmospheric pressure to high vacuum. The KF flange is manufactured from 304 stainless steel and has a leak rate less than 1E⁻⁹ std cc/sec and can be baked to 150 °C when using a Viton O-Ring.

Klump Fittings

Employing the easy release clamping design, these fittings offer a quick and simple solution to vacuum system design and assembly. Bakeable to 150 °C when using Viton O-Rings, these fittings are ideal for roughing or high vacuum applications.

Klump-Flanges & Fittings

	Page
Quick Clamps	40
Centering Rings	42
Replacement O-Rings	46
Blank-Off Flanges	47
Unbored Stubs	49
Weld Sockets	50
Weld Stubs.....	51
Nipples.....	53
Elbows.....	54
Tees.....	55
4-Way Crosses	56
Reducers	56
KF to CFF Adapters	58
Pipe Adapters	60
Flexible Couplings	64
Compression Port Adapters	66
Swagelok and VCR Adapters	68
PVC Cord-reinforced Flexible Vacuum Hose.....	70
Aluminum Hose Adapter	70

KLAMPS FLANGES & FITTINGS

▶ Quick Clamps with Ratchet Closure NW10 - NW50 (ISO)

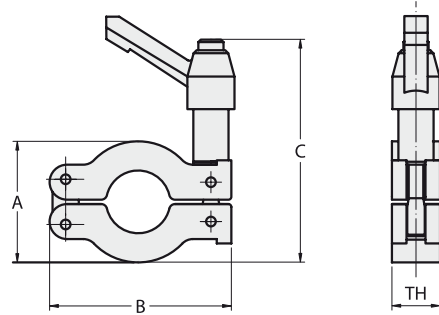

Specifications

- Aluminum
- Black or Metallic Finish

Ordering Information – (Black or Metallic Finish)

Description	Black	Metallic	A in. (mm)	B in. (mm)	C in. (mm)	Thickness in. (mm)	Weight lbs (kg)
NW10/16	KQ16AR	KQ16ARP	1.57 (40.00)	2.45 (62.30)	3.12 (79.25)	0.65 (16.50)	1.0 (0.5)
NW25	KQ25AR	KQ25ARP	2.13 (54.00)	2.85 (72.40)	3.38 (85.85)	0.65 (16.50)	1.0 (0.5)
NW40	KQ40AR	KQ40ARP	2.68 (68.00)	3.53 (89.70)	3.67 (93.22)	0.65 (16.50)	1.0 (0.5)
NW50	KQ50AR	KQ50ARP	3.54 (90.00)	4.80 (122.00)	4.42 (112.27)	0.91 (23.20)	1.0 (0.5)

▶ Quick Clamps with Wing-Nut Closure NW10 - NW50 (ISO)

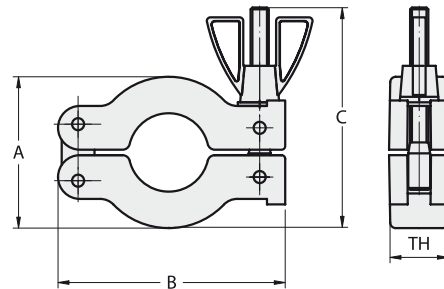

Specifications

- Aluminum
- Black or Plain finish

Ordering Information – (Black or Metallic Finish)

Description	Black	Metallic	A in. (mm)	B in. (mm)	C in. (mm)	Thickness in. (mm)	Weight lbs (kg)
NW10/16	KQ16AW	KQ16AWP	1.57 (40.00)	2.45 (62.30)	2.17 (55.19)	0.65 (16.50)	1.0 (0.5)
NW25	KQ25AW	KQ25AWP	2.13 (54.00)	2.85 (72.40)	2.37 (60.20)	0.65 (16.50)	1.0 (0.5)
NW40	KQ40AW	KQ40AWP	2.68 (68.00)	3.53 (89.70)	2.64 (67.06)	0.65 (16.50)	1.0 (0.5)
NW50	KQ50AW	KQ50AWP	3.54 (90.00)	4.80 (122.00)	3.60 (90.44)	0.91 (23.20)	1.0 (0.5)

VACUUM COMPONENTS

Bulkhead Clamps

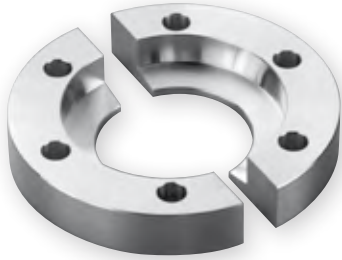

Specifications

- Aluminum
- Provides simple and secure baseplate connection
- Stainless Steel bolts and washers included (10-32 x 5/8)

Ordering Information

Description	Part Number	Bolts	Shipping Weight lbs (kg)
NW16	KBC16	6	0.5 (0.2)
NW25	KBC25	6	0.5 (0.2)
NW40	KBC40	6	0.5 (0.2)
NW50	KBC50	8	0.5 (0.2)

Bulkhead Claw Clamp Kit

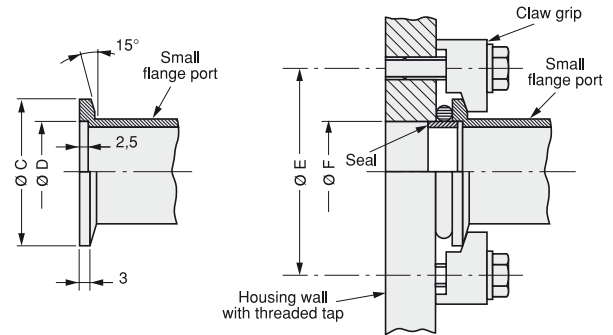
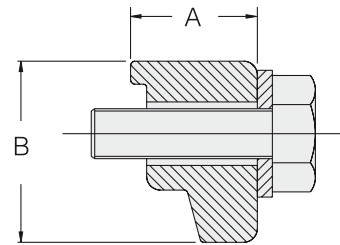
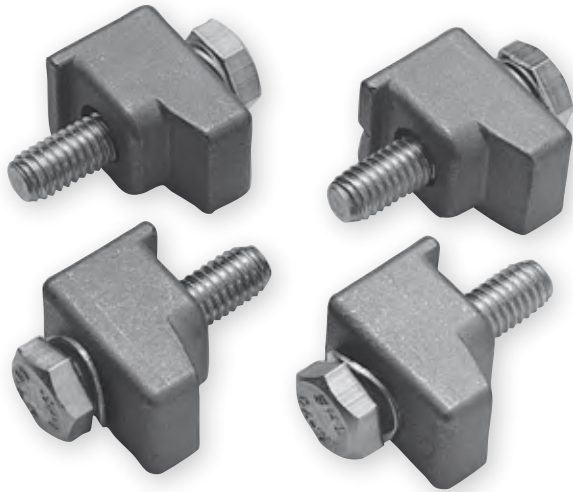

Specifications

- Cast steel
- Spring loaded lock-washers, Single Claw Clamp Kit for bolting KF flanges to bulkheads
- Can be used instead of bulkhead clamps

Nominal Diameter	C	D	E	F	Nr. of Claw Grips
DN 10 KF	30	12.2	45	12.2	4
DN 16 KF	30	17.2	45	17.2	4
DN 25 KF	44	26.2	55	26.2	4
DN 40 KF	55	41.2	71	41.2	4
DN 50 KF	75	52.4	91	52.2	4

Dimensions: millimeters

Ordering Information

Description	Part Number	Qty	A in. (mm)	B in. (mm)	Bolt	Shipping Weight lbs (kg)
NW25 to NW50	KF1050CCS	4	.55 (14)	.79 (20)	M6 x 20 mm	.11 (.05)

KLAMPS FLANGES & FITTINGS

▶ Stainless Steel Centering Rings NW10 – NW50 (ISO)

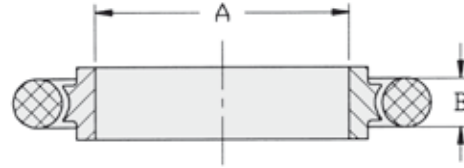
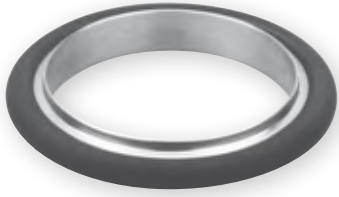

Specifications

- 304 stainless steel centering ring
- Replaceable o-ring
- 100 °C maximum, Buna-N
- 200 °C maximum, Viton

Ordering Information – Centering Rings (Viton)

Description	Part Number	A in. (mm)	B in. (mm)	Shipping Weight lbs (kg)
NW10	KC10SV	0.39 (9.91)	0.21 (5.33)	0.5 (0.2)
NW16	KC16SV	0.63 (16.00)	0.21 (5.33)	0.5 (0.2)
NW25	KC25SV	0.98 (24.89)	0.21 (5.33)	0.5 (0.2)
NW40	KC40SV	1.57 (39.88)	0.21 (5.33)	0.5 (0.2)
NW50	KC50SV	1.97 (50.04)	0.21 (5.33)	0.5 (0.2)

Ordering Information – Centering Rings (Buna-N)

Description	Part Number	A in. (mm)	B in. (mm)	Shipping Weight lbs (kg)
NW10	KC10SB	0.39 (9.91)	0.21 (5.33)	0.5 (0.2)
NW16	KC16SB	0.63 (16.00)	0.21 (5.33)	0.5 (0.2)
NW25	KC25SB	0.98 (24.89)	0.21 (5.33)	0.5 (0.2)
NW40	KC40SB	1.57 (39.88)	0.21 (5.33)	0.5 (0.2)
NW50	KC50SB	1.97 (50.04)	0.21 (5.33)	0.5 (0.2)

Ordering Information – Centering Rings (Silicon)

Description	Part Number	A in. (mm)	B in. (mm)	Shipping Weight lbs (kg)
NW10	KC10SS	0.39 (9.91)	0.21 (5.33)	0.5 (0.2)
NW16	KC16SS	0.63 (16.00)	0.21 (5.33)	0.5 (0.2)
NW25	KC25SS	0.98 (24.89)	0.21 (5.33)	0.5 (0.2)
NW40	KC40SS	1.57 (39.88)	0.21 (5.33)	0.5 (0.2)
NW50	KC50SS	1.97 (50.04)	0.21 (5.33)	0.5 (0.2)

VACUUM COMPONENTS

▶ Aluminum Centering Rings NW10 – NW50 (ISO)

Specifications

- 6061 T6 aluminum centering ring
- Replaceable o-ring
- 100 °C maximum, Buna-N
- 200 °C maximum, Viton

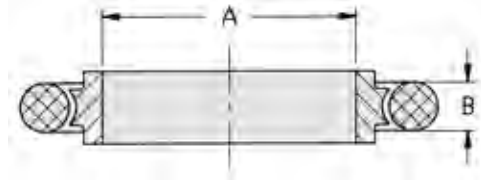

Ordering Information – Centering Rings (Viton)

Description	Part Number	A in. (mm)	B in. (mm)	Shipping Weight lbs (kg)
NW10	KC10AV	0.39 (9.91)	0.21 (5.33)	0.5 (0.2)
NW16	KC16AV	0.63 (16.00)	0.21 (5.33)	0.5 (0.2)
NW25	KC25AV	0.98 (24.89)	0.21 (5.33)	0.5 (0.2)
NW40	KC40AV	1.57 (39.88)	0.21 (5.33)	0.5 (0.2)
NW50	KC50AV	1.97 (50.04)	0.21 (5.33)	0.5 (0.2)

Ordering Information – Centering Rings (Buna-N)

Description	Part Number	A in. (mm)	B in. (mm)	Shipping Weight lbs (kg)
NW10	KC10AB	0.39 (9.91)	0.21 (5.33)	0.5 (0.2)
NW16	KC16AB	0.63 (16.00)	0.21 (5.33)	0.5 (0.2)
NW25	KC25AB	0.98 (24.89)	0.21 (5.33)	0.5 (0.2)
NW40	KC40AB	1.57 (39.88)	0.21 (5.33)	0.5 (0.2)
NW50	KC50AB	1.97 (50.04)	0.21 (5.33)	0.5 (0.2)

KLAMPS FLANGES & FITTINGS

► Adaptive Stainless Steel Centering Rings NW10 – NW40 (ISO)

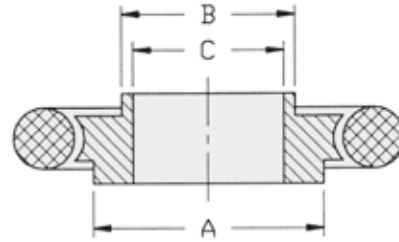

Specifications

- 304 stainless steel centering ring
- Replaceable o-ring
- 100 °C maximum, Buna-N
- 200 °C maximum, Viton

Ordering Information – Adaptive Centering Rings (Viton)

Description	Part Number	A in. (mm)	B in. (mm)	C in. (mm)	Shipping Weight lbs (kg)
NW10 to NW16	KCA1016SV	0.67 (17.02)	0.47 (11.94)	0.39 (9.91)	0.5 (0.2)
NW20 to NW25	KCA2025SV	1.02 (25.91)	0.87 (22.10)	0.79 (20.01)	0.5 (0.2)
NW32 to NW40	KCA3240SV	1.61 (40.89)	1.34 (34.04)	1.26 (32.00)	0.5 (0.2)

Ordering Information – Adaptive Centering Rings (Buna-N)

Description	Part Number	A in. (mm)	B in. (mm)	C in. (mm)	Shipping Weight lbs (kg)
NW10 to NW16	KCA1016SB	0.67 (17.02)	0.47 (11.94)	0.39 (9.91)	0.5 (0.2)
NW32 to NW40	KCA3240SB	1.61 (40.89)	1.34 (34.04)	1.26 (32.00)	0.5 (0.2)

► Adaptive Aluminum Centering Rings NW10 – NW40 (ISO)

Specifications

- 6061 T6 aluminum centering ring
- Replaceable o-ring
- 100 °C maximum, Buna-N
- 200 °C maximum, Viton

Ordering Information – Adaptive Centering Rings (Viton)

Description	Part Number	A in. (mm)	B in. (mm)	C in. (mm)	Shipping Weight lbs (kg)
NW10 to NW16	KCA1016AV	0.67 (17.02)	0.47 (11.94)	0.39 (9.91)	0.5 (0.2)
NW20 to NW25	KCA2025AV	1.02 (25.91)	0.87 (22.10)	0.79 (20.01)	0.5 (0.2)

Ordering Information – Adaptive Centering Rings (Buna-N)

Description	Part Number	A in. (mm)	B in. (mm)	C in. (mm)	Shipping Weight lbs (kg)
NW20 to NW25	KCA2025AB	1.02 (25.91)	0.87 (22.10)	0.79 (20.01)	0.5 (0.2)
NW32 to NW40	KCA3240AB	1.61 (40.89)	1.34 (34.04)	1.26 (32.00)	0.5 (0.2)

VACUUM COMPONENTS

▶ Stainless Steel Centering Rings with Screen NW16 – NW50 (ISO)

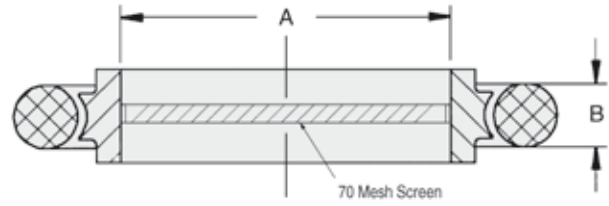
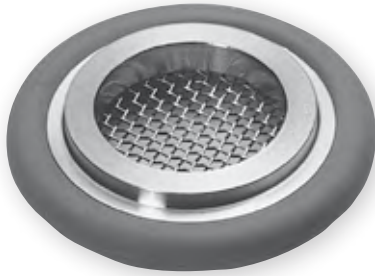

Specifications

- 304 stainless steel centering ring
- Replaceable o-ring
- 200 °C maximum, Viton
- 70 mesh screen (0.2 x 0.2 x 0.15 mm)

Ordering Information – Centering Rings (Viton)

Description	Part Number	A in. (mm)	B in. (mm)	Shipping Weight lbs (kg)
NW16	KC16SV72M	0.37 (9.5)	0.25 (5)	0.5 (0.2)
NW25	KC25SV72M	0.77 (19.5)	0.25 (5)	0.5 (0.2)
NW40	KC40SV72M	1.26 (32.0)	0.25 (5)	0.5 (0.2)
NW50	KC50SV72M	1.67 (43.0)	0.25 (5)	0.5 (0.2)

KLAMPS FLANGES & FITTINGS

► Replacement O-Rings NW10 – NW50 (ISO)

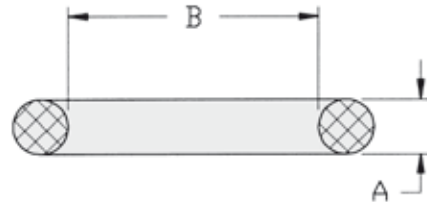

Specifications

- 100 °C maximum, Buna-N
- 200 °C maximum, Viton

Ordering Information – Replacement O-Rings (Viton)

Description	Part Number	Qty/Pkg	A in. (mm)	B in. (mm)	Shipping Weight lbs (kg)
NW10	KG10V	10	0.21 (5.33)	0.60 (15.24)	0.5 (0.2)
NW16	KG16V	10	0.21 (5.33)	0.73 (18.42)	0.5 (0.2)
NW25	KG25V	10	0.21 (5.33)	1.10 (27.94)	0.5 (0.2)
NW40	KG40V	10	0.21 (5.33)	1.60 (40.64)	0.5 (0.2)
NW50	KG50V	10	0.21 (5.33)	2.10 (53.34)	0.5 (0.2)

Ordering Information – Replacement O-Rings (Buna-N)

Description	Part Number	Qty/Pkg	A in. (mm)	B in. (mm)	Shipping Weight lbs (kg)
NW10	KG10B	10	0.21 (5.33)	0.60 (15.24)	0.5 (0.2)
NW16	KG16B	10	0.21 (5.33)	0.73 (18.42)	0.5 (0.2)
NW25	KG25B	10	0.21 (5.33)	1.10 (27.94)	0.5 (0.2)
NW40	KG40B	10	0.21 (5.33)	1.60 (40.64)	0.5 (0.2)
NW50	KG50B	10	0.21 (5.33)	2.10 (53.34)	0.5 (0.2)

Ordering Information – Replacement O-Rings (Silicon)

Description	Part Number	Qty/Pkg	A in. (mm)	B in. (mm)	Shipping Weight lbs (kg)
NW10	KG10S	10	0.21 (5.33)	0.60 (15.24)	0.5 (0.2)
NW16	KG16S	10	0.21 (5.33)	0.73 (18.42)	0.5 (0.2)
NW25	KG25S	10	0.21 (5.33)	1.10 (27.94)	0.5 (0.2)
NW40	KG40S	10	0.21 (5.33)	1.60 (40.64)	0.5 (0.2)
NW50	KG50S	10	0.21 (5.33)	2.10 (53.34)	0.5 (0.2)

VACUUM COMPONENTS

▶ Blank-Off Flanges NW10 – NW50 (ISO)

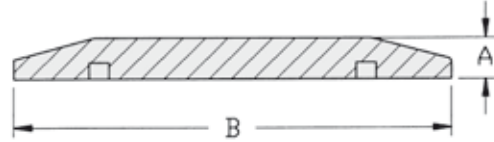

Specifications

- 304 stainless steel
- 6061 T6 aluminum
- Use as blank-off port
- Can be machined and welded

Ordering Information – Blank-Off Flanges (Stainless Steel)

Description	Part Number	A in. (mm)	B in. (mm)	Shipping Weight lbs (kg)
NW10/16	KF160000SB	0.20 (5.08)	1.18 (29.97)	0.5 (0.2)
NW25	KF250000SB	0.20 (5.08)	1.58 (40.13)	0.5 (0.2)
NW40	KF400000SB	0.20 (5.08)	2.17 (55.12)	0.5 (0.2)
NW50	KF500000SB	0.20 (5.08)	2.95 (74.93)	0.5 (0.2)

Ordering Information – Blank-Off Flanges (Aluminum)

Description	Part Number	A in. (mm)	B in. (mm)	Shipping Weight lbs (kg)
NW10/16	KF160000AB	0.20 (5.08)	1.18 (29.97)	0.5 (0.2)
NW25	KF250000AB	0.20 (5.08)	1.58 (40.13)	0.5 (0.2)
NW40	KF400000AB	0.20 (5.08)	2.17 (55.12)	0.5 (0.2)
NW50	KF500000AB	0.20 (5.08)	2.95 (74.93)	0.5 (0.2)

KLAMPS FLANGES & FITTINGS

► Bored Blank-Off Flanges NW16 – NW50 (ISO)

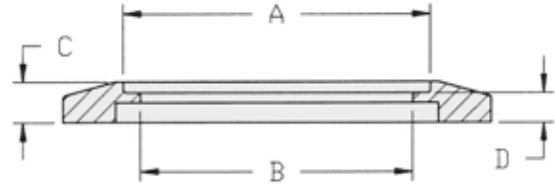

Specifications

- Self-aligning
- 304 stainless steel
- Standard inch size tubing
- Standard tube weld prep

Ordering Information

Description	Part Number	Tube Size A in. (mm)	B in. (mm)	C in. (mm)	D in. (mm)	Shipping Weight lbs (kg)
NW16 (0.75 in. tubing)	KS160075BB	0.76 (19.30)	0.69 (17.53)	0.17 (4.32)	0.15 (3.81)	0.5 (0.2)
NW25 (0.50 in. tubing)	KS250050BB	0.51 (12.95)	0.44 (11.18)	0.19 (4.82)	0.15 (3.81)	0.5 (0.2)
(0.75 in. tubing)	KS250075BB	0.76 (19.30)	0.69 (17.53)	0.19 (4.82)	0.15 (3.81)	0.5 (0.2)
(1.0 in. tubing)	KS250100BB	1.02 (25.91)	0.90 (22.86)	0.19 (4.82)	0.15 (3.81)	0.5 (0.2)
NW40 (1.0 in. tubing)	KS400100BB	1.02 (25.91)	0.90 (22.86)	0.20 (5.08)	0.15 (3.81)	0.5 (0.2)
(1.25 in. tubing)	KS400125BB	1.26 (32.00)	1.12 (28.45)	0.20 (5.08)	0.15 (3.81)	0.5 (0.2)
(1.50 in. tubing)	KS400150BB	1.50 (38.10)	1.37 (34.80)	0.20 (5.08)	0.15 (3.81)	0.5 (0.2)
NW50 (0.75 in. tubing)	KS500075BB	0.76 (19.30)	0.69 (17.53)	0.24 (6.10)	0.15 (3.81)	0.5 (0.2)
(1.50 in. tubing)	KS500150BB	1.52 (38.62)	1.37 (34.80)	0.24 (6.10)	0.15 (3.81)	0.5 (0.2)
(2.00 in. tubing)	KS500200BB	2.02 (51.31)	1.87 (47.50)	0.24 (6.10)	0.15 (3.81)	0.5 (0.2)

VACUUM COMPONENTS

► Unbored Stubs NW16 – NW50 (ISO)

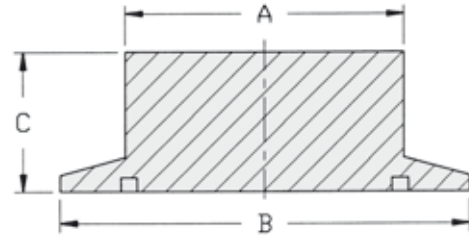

Specifications

- 304 stainless steel
- 6061 T6 aluminum
- Stub can be turned, bored, or tapped to fit

Ordering Information – Unbored Stubs (Stainless Steel)

Description	Part Number	A in. (mm)	B in. (mm)	C in. (mm)	Shipping Weight lbs (kg)
NW16	KS160000SUB	0.75 (19.05)	1.18 (29.97)	0.75 (19.05)	0.5 (0.2)
NW25	KS250000SUB	1.00 (25.40)	1.58 (40.13)	0.75 (19.05)	0.5 (0.2)
NW40	KS400000SUB	1.50 (38.10)	2.17 (55.12)	1.00 (25.40)	0.5 (0.2)
NW50	KS500000SUB	2.00 (50.80)	2.95 (74.93)	1.00 (25.40)	0.5 (0.2)

Ordering Information – Unbored Stubs (Aluminum)

Description	Part Number	A in. (mm)	B in. (mm)	C in. (mm)	Shipping Weight lbs (kg)
NW16	KS160000AUB	0.75 (19.05)	1.18 (29.97)	0.75 (19.05)	0.5 (0.2)
NW25	KS250000AUB	1.00 (25.40)	1.58 (40.13)	0.75 (19.05)	0.5 (0.2)
NW40	KS400000AUB	1.50 (38.10)	2.17 (55.12)	1.00 (25.40)	0.5 (0.2)
NW50	KS500000AUB	2.00 (50.80)	2.95 (74.93)	1.00 (25.40)	0.5 (0.2)

KLAMPS FLANGES & FITTINGS

► Weld Sockets NW10 – NW50 (ISO)

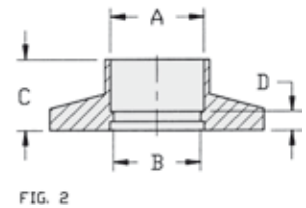
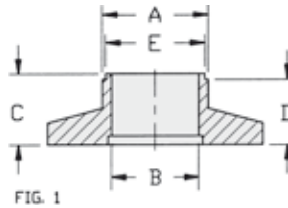

Specifications

- Self-aligning
- 304 stainless steel
- Socket weld
- Standard tube weld prep

Ordering Information

Description	Part Number	A in. (mm)	B in. (mm)	C in. (mm)	D in. (mm)	E in. (mm)	Weight lbs (kg)
NW10 (.50 in. tubing)	KS100050056SW	0.52 (13.21)	0.48 (12.19)	0.56 (14.20)	0.50 (12.70)	0.42 (10.67)	0.5 (0.2)
NW16 (.50 in. tubing)	KS160050050SW	0.51 (12.95)	0.45 (11.43)	0.50 (12.70)	0.25 (6.35)	N/A	0.5 (0.2)
NW16 (.75 in. tubing)	KS160075050SW	0.76 (19.30)	0.68 (17.27)	0.50 (12.70)	0.25 (6.35)	N/A	0.5 (0.2)
NW25 (1 in. tubing)	KS250100047SW	1.02 (25.92)	0.90 (23.00)	0.47 (12.00)	0.17 (4.30)	N/A	0.5 (0.2)
	KS250100050SW	1.02 (25.92)	0.87 (22.10)	0.50 (12.70)	0.25 (6.40)	N/A	0.5 (0.2)
	KS250100052SW	1.02 (25.92)	0.90 (23.00)	0.52 (13.20)	0.22 (5.60)	N/A	0.5 (0.2)
NW40 (1.5 in. tubing)	KS400150030SW	1.51 (38.35)	1.37 (34.80)	0.30 (7.60)	0.21 (5.30)	N/A	0.5 (0.2)
	KS400150040SW	1.51 (38.35)	1.37 (34.80)	0.40 (10.20)	0.31 (7.80)	N/A	0.5 (0.2)
	KS400150050SW	1.51 (38.35)	1.37 (34.80)	0.50 (12.70)	0.21 (5.30)	N/A	0.5 (0.2)
	KS40015005ASW	1.51 (38.35)	1.37 (34.80)	0.50 (12.70)	0.25 (6.40)	N/A	0.5 (0.2)
NW50 (2 in. tubing)	KS500200050SW	2.02 (51.31)	1.87 (47.50)	0.50 (12.70)	0.25 (6.40)	N/A	0.5 (0.2)
	KS500200062SW	2.02 (51.31)	1.87 (47.50)	0.62 (15.70)	0.22 (5.60)	N/A	0.5 (0.2)

* See Fig. 1; all other Part Numbers see Fig. 2.

VACUUM COMPONENTS

▶ Short Weld Stubs NW16 – NW50 (ISO)

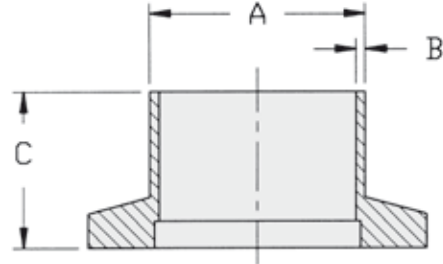

Specifications

- Butt weld
- Standard and metric tube sizes

Ordering Information – Short Weld Stubs (304 Stainless Steel)

Description	Part Number	Tube Size A in. (mm)	B in. (mm)	C in. (mm)	Shipping Weight lbs (kg)
NW16 (.50 in. tubing)	KS160050050	0.50 (12.70)	0.065 (1.65)	0.50 (12.70)	0.5 (0.2)
NW16 (.75 in. tubing)	KS160075050	0.75 (19.05)	0.065 (1.65)	0.50 (12.70)	0.5 (0.2)
	KS160078078	0.78 (19.81)	0.080 (2.03)	0.78 (19.81)	0.5 (0.2)
NW25 (1 in. tubing)	KS250100050	1.00 (25.40)	0.065 (1.65)	0.50 (12.70)	0.5 (0.2)
	KS250100057	1.00 (25.40)	0.049 (1.24)	0.57 (14.48)	0.5 (0.2)
	KS250110078	1.10 (27.94)	0.077 (1.95)	0.78 (19.81)	0.5 (0.2)
NW40 (1.50 in. tubing)	KS400150057	1.50 (38.10)	0.065 (1.65)	0.57 (14.48)	0.5 (0.2)
	KS400150075	1.50 (38.10)	0.065 (1.65)	0.75 (19.05)	0.5 (0.2)
	KS400175100	1.75 (44.45)	0.078 (1.98)	1.00 (25.40)	0.5 (0.2)
NW50 (2 in. tubing)	KS500200057	2.00 (50.80)	0.065 (1.65)	0.57 (14.48)	0.5 (0.2)
	KS500220100	2.20 (55.88)	0.117 (2.97)	1.00 (25.40)	0.5 (0.2)

Ordering Information – Short Weld Stubs (6061 T6 Aluminum)

Description	Part Number	Tube Size A in. (mm)	B in. (mm)	C in. (mm)	Shipping Weight lbs (kg)
NW16 (.75 in. tubing)	KS160075050A	0.75 (19.05)	0.065 (1.65)	0.50 (12.70)	0.5 (0.2)
NW40 (1.5 in. tubing)	KS400150075A	1.50 (38.10)	0.065 (1.65)	0.75 (19.05)	0.5 (0.2)

KLAMPS FLANGES & FITTINGS

▶ Long Weld Stubs NW16 – NW50 (ISO)

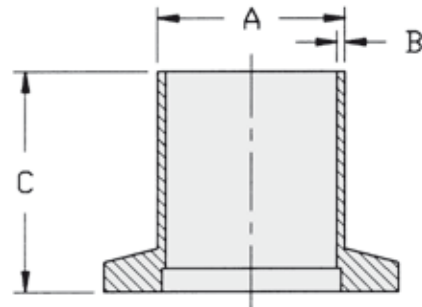

Specifications

- Butt weld
- Standard and metric tube sizes

Ordering Information – Long Weld Stubs (304 Stainless Steel)

Description	Part Number	Tube Size A in. (mm)	B in. (mm)	C in. (mm)	Shipping Weight lbs (kg)
NW16 (.50 in. tubing)	KS160050157	0.50 (12.70)	0.065 (1.65)	1.57 (40.0)	0.5 (0.2)
NW16 (.75 in. tubing)	KS160075115	0.75 (19.05)	0.035 (0.89)	1.15 (29.2)	0.5 (0.2)
	KS160075157	0.75 (19.05)	0.065 (1.65)	1.57 (40.0)	0.5 (0.2)
	KS160078197	0.78 (19.81)	0.078 (1.98)	1.97 (50.0)	0.5 (0.2)
NW25 (1 in. tubing)	KS250100143	1.00 (25.40)	0.049 (1.24)	1.43 (36.6)	0.5 (0.2)
	KS250100157	1.00 (25.40)	0.065 (1.65)	1.57 (40.0)	0.5 (0.2)
	KS250100203	1.00 (25.40)	0.065 (1.65)	2.03 (51.6)	0.5 (0.2)
	KS250110197	1.10 (27.94)	0.077 (1.95)	1.97 (50.0)	0.5 (0.2)
NW40 (1.50 in. tubing)	KS400150157	1.50 (38.10)	0.065 (1.65)	1.57 (40.0)	0.5 (0.2)
	KS400150175	1.50 (38.10)	0.065 (1.65)	1.75 (44.5)	0.5 (0.2)
	KS400150246	1.50 (38.10)	0.065 (1.65)	2.46 (62.5)	1.0 (0.5)
	KS400175197	1.75 (44.45)	0.083 (2.11)	1.97 (50.0)	0.5 (0.2)
NW50 (2 in. tubing)	KS500200157	2.00 (50.80)	0.065 (1.65)	1.57 (40.0)	0.5 (0.2)
	KS500200169	2.00 (50.80)	0.065 (1.65)	1.69 (42.9)	0.5 (0.2)
	KS500220217	2.20 (55.88)	0.117 (2.97)	2.17 (55.1)	0.5 (0.2)

Ordering Information – Long Weld Stubs (6061 T6 Aluminum)

Description	Part Number	Tube Size A in. (mm)	B in. (mm)	C in. (mm)	Shipping Weight lbs (kg)
NW16 (.50 in. tubing)	KS160050157A	0.50 (12.70)	0.065 (1.65)	1.57 (39.88)	0.5 (0.2)
NW16 (.75 in. tubing)	KS160075157A	0.75 (19.05)	0.065 (1.65)	1.57 (39.88)	0.5 (0.2)
NW25 (1 in. tubing)	KS250100157A	1.00 (25.40)	0.065 (1.65)	1.57 (39.88)	0.5 (0.2)
NW40 (1.5 in. tubing)	KS400150157A	1.50 (38.10)	0.083 (2.11)	1.57 (39.88)	0.5 (0.2)
NW50 (2 in. tubing)	KS500200157A	2.00 (50.80)	0.083 (2.11)	1.57 (39.88)	0.5 (0.2)

VACUUM COMPONENTS

▶ Nipples NW16 – NW50 (ISO)

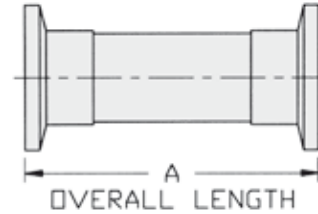
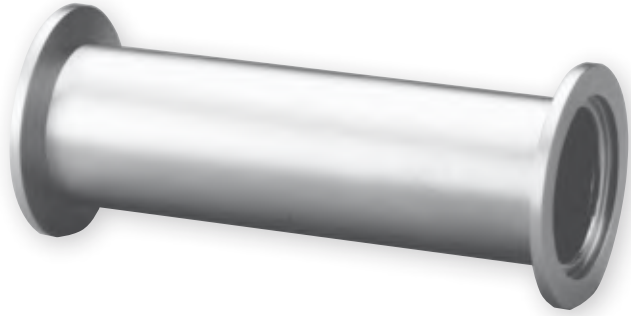

Specifications

- 304 stainless steel
- ISO-KF flanges
- Same flanges on both ports
- Full penetration vacuum welds
- Custom lengths available

Ordering Information

Description	Part Number	A in. (mm)	Shipping Weight lbs (kg)
NW16	KNF00750230	2.30 (58.42)	1.0 (0.5)
	KNF00750315	3.15 (80.01)	1.0 (0.5)
	KNF00750645	6.45 (163.83)	2.0 (0.9)
	KNF00751260	12.60 (320.04)	3.0 (1.4)
NW25	KNF01000394	3.94 (100.08)	1.0 (0.5)
	KNF01000406	4.06 (103.12)	1.0 (0.5)
	KNF01000408	4.08 (103.63)	1.0 (0.5)
	KNF01000803	8.03 (203.96)	2.0 (0.9)
	KNF01001260	12.60 (320.04)	3.0 (1.4)
NW40	KNF01500480	4.80 (121.92)	1.0 (0.5)
	KNF01500493	4.93 (125.22)	1.0 (0.5)
	KNF01500512	5.12 (130.05)	1.0 (0.5)
	KNF01501039	10.39 (263.91)	4.0 (1.8)
	KNF01501260	12.60 (320.04)	4.0 (1.8)
NW50	KNF02000551	5.51 (139.95)	1.0 (0.5)
	KNF02000630	6.30 (160.02)	1.0 (0.5)
	KNF02000643	6.43 (163.32)	1.0 (0.5)
	KNF02001118	11.18 (283.97)	4.0 (1.8)
	KNF02001260	12.60 (320.04)	4.0 (1.8)

KLAMPS FLANGES & FITTINGS

► Elbows (90°) NW16 – NW50 (ISO)

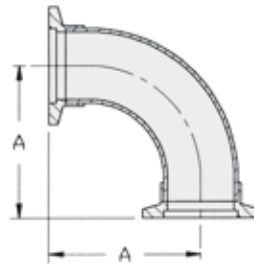

FIG. 1

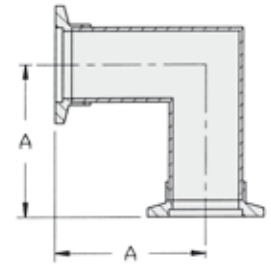

FIG. 2

Specifications

- 304 stainless steel
- ISO-KF Flanges
- Same flanges on both ports
- Full penetration vacuum welds
- Custom configurations available

Ordering Information

Description	Part Number	A in. (mm)	Fig. Number	Shipping Weight lbs (kg)
NW16	KE00750150	1.50 (38.10)	1	1.0 (0.5)
	KE00750157	1.57 (39.88)	1	1.0 (0.5)
NW25	KE01000197	1.97 (50.04)	1	1.0 (0.5)
	KE01000204	2.04 (51.82)	1	1.0 (0.5)
NW40	KE01500246	2.46 (62.48)	1	2.0 (0.9)
	KE01500256	2.56 (65.02)	1	2.0 (0.9)
NW50	KE02000276	2.76 (70.10)	2	2.0 (0.9)
	KE02000321	3.21 (81.53)	2	2.0 (0.9)

VACUUM COMPONENTS

► Tees NW16 – NW50 (ISO)

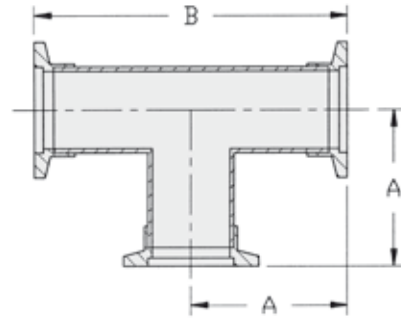

Specifications

- 304 stainless steel
- ISO-KF flanges
- Same flanges on all ports
- Full penetration vacuum welds

Ordering Information

Description	Part Number	A in. (mm)	B in. (mm)	Shipping Weight lbs (kg)
NW16	KT00750150	1.50 (38.10)	3.00 (76.20)	1.5 (0.7)
	KT00750157	1.57 (39.88)	3.15 (80.01)	1.5 (0.7)
NW25	KT01000197	1.97 (50.04)	3.94 (100.08)	2.0 (0.9)
	KT01000204	2.04 (51.82)	4.08 (103.63)	2.0 (0.9)
NW40	KT01500246	2.46 (62.48)	4.92 (124.97)	2.0 (0.9)
	KT01500256	2.56 (65.02)	5.12 (130.05)	2.0 (0.9)
NW50	KT02000276	2.76 (70.10)	5.52 (140.21)	3.0 (1.4)
	KT02000321	3.21 (81.53)	6.42 (163.07)	3.0 (1.4)

KLAMPS FLANGES & FITTINGS

► 4-Way Crosses NW16 – NW50 (ISO)

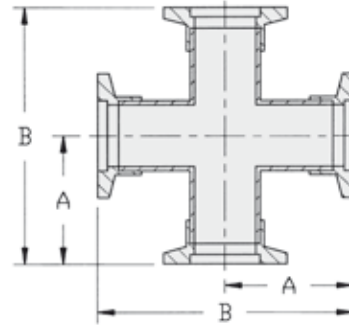
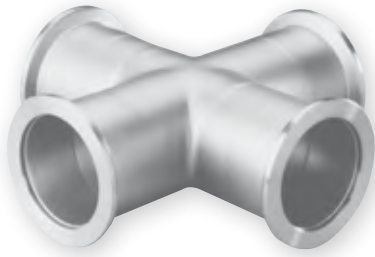

Specifications

- 304 stainless steel
- ISO-KF flanges
- Same flanges on all ports
- Full penetration vacuum welds

Ordering Information

Description	Part Number	A in. (mm)	B in. (mm)	Shipping Weight lbs (kg)
NW16	KC00750150	1.50 (38.10)	3.00 (76.20)	1.5 (0.7)
	KC00750157	1.57 (39.88)	3.14 (80.01)	1.5 (0.7)
NW25	KC01000197	1.97 (50.04)	3.94 (100.08)	2.0 (0.9)
	KC01000204	2.04 (51.82)	4.08 (103.63)	2.0 (0.9)
NW40	KC01500246	2.46 (62.48)	4.92 (124.97)	3.0 (1.4)
	KC01500256	2.56 (65.02)	5.12 (130.05)	3.0 (1.4)
NW50	KC02000276	2.76 (70.10)	5.52 (140.21)	3.0 (1.4)
	KC02000321	3.21 (81.53)	6.44 (163.60)	3.0 (1.4)

► Straight Reducers NW16 – NW50 (ISO)

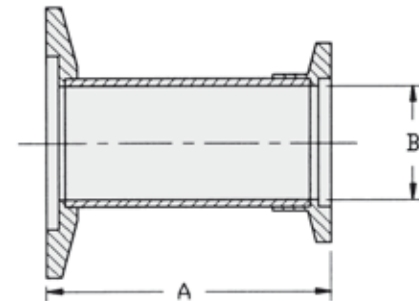

Specifications

- 304 stainless steel
- Straight through

Ordering Information

Description	Part Number	A in. (mm)	B in. (mm)	Shipping Weight lbs (kg)
NW16 to NW25	KRS1625	1.57 (39.88)	0.69 (17.53)	1.0 (0.5)
NW16 to NW40	KRS1640	1.57 (39.88)	0.69 (17.53)	1.0 (0.5)
NW16 to NW50	KRS1650	1.57 (39.88)	0.69 (17.53)	1.0 (0.5)
NW25 to NW40	KRS2540	1.57 (39.88)	0.90 (22.86)	1.0 (0.5)
NW25 to NW50	KRS2550	1.57 (39.88)	0.90 (22.86)	1.0 (0.5)
NW40 to NW50	KRS4050	1.57 (39.88)	1.37 (34.80)	1.0 (0.5)

VACUUM COMPONENTS

► Conical Reducers NW16 – NW50 (ISO)

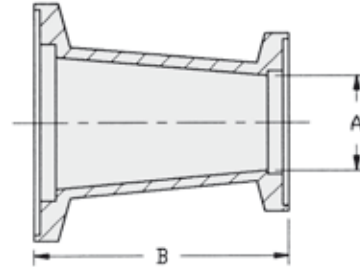

Specifications

- 304 stainless steel
- 6061 T6 aluminum

Ordering Information – Conical Reducers (304 Stainless Steel)

Description	Part Number	A in. (mm)	B in. (mm)	Shipping Weight lbs (kg)
NW16 to NW25	KRC1625S	0.62 (15.75)	1.65 (41.91)	1.0 (0.5)
NW16 to NW40	KRC1640S	0.62 (15.75)	1.65 (41.91)	1.0 (0.5)
NW16 to NW50	KRC1650S	0.62 (15.75)	1.65 (41.91)	1.0 (0.5)
NW25 to NW40	KRC2540S	0.87 (22.10)	1.65 (41.91)	1.0 (0.5)
NW25 to NW50	KRC2550S	0.87 (22.10)	1.65 (41.91)	1.0 (0.5)
NW40 to NW50	KRC4050S	1.37 (34.80)	1.65 (41.91)	1.0 (0.5)

Ordering Information – Conical Reducers (6061 T6 Aluminum)

Description	Part Number	A in. (mm)	B in. (mm)	Shipping Weight lbs (kg)
NW16 to NW25	KRC1625A	0.62 (15.75)	1.65 (41.91)	1.0 (0.5)
NW16 to NW40	KRC1640A	0.62 (15.75)	1.65 (41.91)	1.0 (0.5)
NW16 to NW50	KRC1650A	0.62 (15.75)	1.65 (41.91)	1.0 (0.5)
NW25 to NW40	KRC2540A	0.87 (22.10)	1.65 (41.91)	1.0 (0.5)
NW25 to NW50	KRC2550A	0.87 (22.10)	1.65 (41.91)	1.0 (0.5)
NW40 to NW50	KRC4050A	1.37 (34.80)	1.65 (41.91)	1.0 (0.5)

KLAMPS FLANGES & FITTINGS

► KF to CFF Adapters

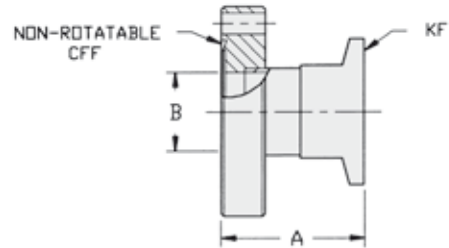
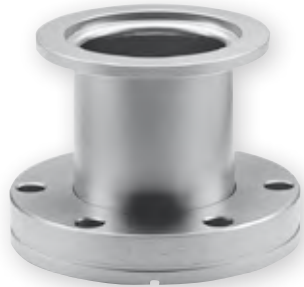

Ordering Information

CFF Size	Part Number	CFF OD	KF Flange		Overall Length A in. (mm)	Tube ID B in. (mm)	Shipping Weight lbs (kg)
			NW	Size OD			
1 1/2 in.	FA0133NW16S	1.33	NW16	1.18	1.57 (39.88)	0.68 (17.27)	1.0 (0.5)
	FA0133NW16	1.33	NW16	1.18	2.00 (50.80)	0.68 (17.27)	1.0 (0.5)
	FA0133NW16L	1.33	NW16	1.18	2.07 (52.70)	0.68 (17.27)	1.0 (0.5)
	FA0133NW25	1.33	NW25	1.57	2.00 (50.80)	0.68 (17.27)	1.5 (0.7)
2 3/4 in.	FA0275NW16S	2.73	NW16	1.18	1.78 (45.21)	0.68 (17.27)	1.5 (0.7)
	FA0275NW16	2.73	NW16	1.18	2.00 (50.80)	0.68 (17.27)	1.5 (0.7)
	FA0275NW16L	2.73	NW16	1.18	2.36 (59.94)	0.68 (17.27)	1.5 (0.7)
	FA0275NW25S	2.73	NW25	1.57	1.78 (45.21)	0.87 (22.10)	1.5 (0.7)
	FA0275NW25	2.73	NW25	1.57	2.00 (50.80)	0.87 (22.10)	1.5 (0.7)
	FA0275NW25L	2.73	NW25	1.57	2.36 (59.94)	0.87 (22.10)	1.5 (0.7)
	FA0275NW40S	2.73	NW40	2.16	1.78 (45.21)	1.37 (34.80)	2.0 (0.9)
	FA0275NW40	2.73	NW40	2.16	2.00 (50.80)	1.37 (34.80)	2.0 (0.9)
	FA0275NW40L	2.73	NW40	2.16	2.55 (64.77)	1.37 (34.80)	2.0 (0.9)
4 1/2 in.	FA0450NW40	4.47	NW40	2.16	2.00 (50.80)	1.37 (34.80)	3.0 (1.4)
	FA0450NW50L	4.47	NW50	2.95	2.00 (50.80)	1.87 (47.50)	3.0 (1.4)
	FA0450NW50	4.47	NW50	2.95	1.95 (49.53)	1.87 (34.80)	3.0 (1.4)

VACUUM COMPONENTS

Accessories

Size	Gasket	Description	Part Number	Qty/Pkg	Shipping Weight lbs (kg)
1 1/8 in.	Copper	10-pack, individually sealed	FG0133CI	10	1.0 (0.5)
	Viton	5-pack	FG0133VU	5	0.5 (0.2)
2 1/8 in.	Copper	10-pack, individually sealed	FG0212CI	10	1.0 (0.5)
	Viton	5-pack	FG0212VU	5	0.5 (0.2)
2 3/8 in.	Copper	10-pack, individually sealed	FG0275CI	10	1.0 (0.5)
	Viton	5-pack	FG0275VU	5	0.5 (0.2)
3 3/8 in.	Copper	10-pack, individually sealed	FG0338CI	10	1.0 (0.5)
	Viton	1-pack	FG0338VU	1	0.5 (0.2)
4 1/2 in.	Copper	10-pack, individually sealed	FG0450CI	10	2.0 (0.9)
	Viton	1-pack	FG0450VU	1	0.5 (0.2)

Accessories

Size	Nut and Bolt Sets	Hex Head Part Number	12-Point Bolt Part Number	Qty/Pkg	Shipping Weight lbs (kg)
1 1/8 in.	Clear hole flanges	N/A	FB0133C**	25	0.5 (0.2)
	Tapped hole flanges	N/A	FB0133T**	25	0.5 (0.2)
2 1/8 in.	Clear hole flanges	FB0275C06	FB0275C12	25	1.0 (0.5)
	Tapped hole flanges	FB0275T06	FB0275T12	25	1.0 (0.5)
2 3/8 in.	Clear hole flanges	FB0275C06	FB0275C12	25	1.0 (0.5)
	Tapped hole flanges	FB0275T06	FB0275T12	25	1.0 (0.5)
3 3/8 in.	Clear hole flanges	FB0338C06	FB0338C12	25	2.0 (0.9)
	Tapped hole flanges	FB0450T06	FB0450T12	25	2.0 (0.9)
4 1/2 in.	Clear hole flanges	FB0450C06	FB0450C12	25	2.0 (0.9)
	Tapped hole flanges	FB0450T06	FB0450T12	25	2.0 (0.9)

* Includes nuts, washers, and bolts

** Only available in Socket Head

Accessories

Size	Description	Part Number	Qty/Pkg	Shipping Weight lbs (kg)
NW16	Viton Centering Ring	KC16SV	1	0.5 (0.2)
NW25	Viton Centering Ring	KC25SV	1	0.5 (0.2)
NW40	Viton Centering Ring	KC40SV	1	0.5 (0.2)
NW50	Viton Centering Ring	KC50SV	1	0.5 (0.2)
NW16	KF Clamp	KQ16AR	1	0.5 (0.2)
NW25	KF Clamp	KQ25AR	1	0.5 (0.2)
NW40	KF Clamp	KQ40AR	1	1.0 (0.5)
NW50	KF Clamp	KQ50AR	1	1.0 (0.5)

KLAMPS FLANGES & FITTINGS

▶ Stainless Steel Male Pipe Adapters NW16 – NW40 (ISO)

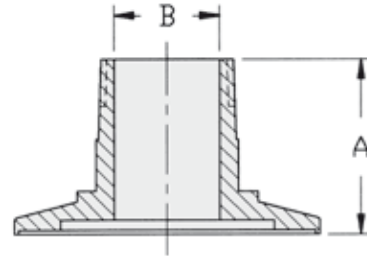

Specifications

- 304 stainless steel
- Male pipe threads
- Wrench flats on shank

Ordering Information

Description	Part Number	A in. (mm)	B in. (mm)	Shipping Weight lbs (kg)	
NW16	1/8 NPT	KAMP160125S	1.47 (37.34)	0.19 (4.83)	1.0 (0.5)
	1/4 NPT	KAMP160250S	1.47 (37.34)	0.28 (7.11)	1.0 (0.5)
	3/8 NPT	KAMP160375S	1.47 (37.34)	0.42 (10.70)	1.0 (0.5)
	1/2 NPT	KAMP160500S	1.69 (42.93)	0.58 (14.73)	1.0 (0.5)
NW25	1/8 NPT	KAMP250125S	1.47 (37.34)	0.19 (4.83)	1.0 (0.5)
	1/4 NPT	KAMP250250S	1.47 (37.34)	0.28 (7.11)	1.0 (0.5)
	3/8 NPT	KAMP250375S	1.47 (37.34)	0.42 (10.70)	1.0 (0.5)
	1/2 NPT	KAMP250500S	1.69 (42.93)	0.58 (14.73)	1.0 (0.5)
	3/4 NPT	KAMP250750S	1.69 (42.93)	0.78 (19.81)	1.0 (0.5)
NW40	1/4 NPT	KAMP400250S	1.47 (37.34)	0.28 (7.11)	1.0 (0.5)
	3/8 NPT	KAMP400375S	1.47 (37.34)	0.42 (10.70)	1.0 (0.5)
	1/2 NPT	KAMP400500S	1.69 (42.93)	0.58 (14.73)	1.0 (0.5)
	3/4 NPT	KAMP400750S	1.69 (42.93)	0.78 (19.81)	1.0 (0.5)
	1NPT	KAMP401000S	1.69 (42.93)	1.02 (25.91)	1.0 (0.5)

VACUUM COMPONENTS

▶ Aluminum Male Pipe Adapters NW16 – NW40 (ISO)

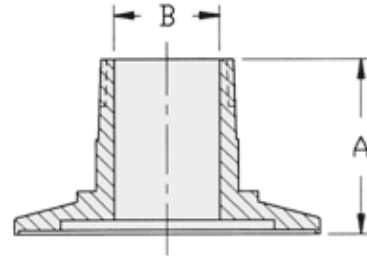

Specifications

- 6061 T6 aluminum
- Male pipe threads
- Wrench flats on shank

Ordering Information

Description	Part Number	A in. (mm)	B in. (mm)	Shipping Weight lbs (kg)	
NW16	1/8 NPT	KAMP160125A	1.47 (37.34)	0.19 (4.83)	1.0 (0.5)
	1/4 NPT	KAMP160250A	1.47 (37.34)	0.28 (7.11)	1.0 (0.5)
	3/8 NPT	KAMP160375A	1.47 (37.34)	0.42 (10.70)	1.0 (0.5)
	1/2 NPT	KAMP160500A	1.69 (42.93)	0.58 (14.73)	1.0 (0.5)
NW25	1/8 NPT	KAMP250125A	1.47 (37.34)	0.19 (4.83)	1.0 (0.5)
	1/4 NPT	KAMP250250A	1.47 (37.34)	0.28 (7.11)	1.0 (0.5)
	3/8 NPT	KAMP250375A	1.47 (37.34)	0.42 (10.70)	1.0 (0.5)
	1/2 NPT	KAMP250500A	1.69 (42.93)	0.58 (14.73)	1.0 (0.5)
	3/4 NPT	KAMP250750A	1.69 (42.93)	0.78 (19.81)	1.0 (0.5)
NW40	1/4 NPT	KAMP400250A	1.47 (37.34)	0.28 (7.11)	1.0 (0.5)
	3/8 NPT	KAMP400375A	1.47 (37.34)	0.42 (10.70)	1.0 (0.5)
	1/2 NPT	KAMP400500A	1.69 (42.93)	0.58 (14.73)	1.0 (0.5)
	3/4 NPT	KAMP400750A	1.69 (42.93)	0.78 (19.81)	1.0 (0.5)
	1NPT	KAMP401000A	1.69 (42.93)	1.02 (25.91)	1.0 (0.5)

KLAMPS FLANGES & FITTINGS

► Stainless Steel Female Pipe Adapters NW16 – NW40 (ISO)

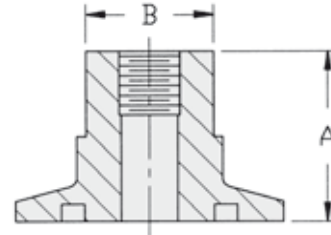

Specifications

- 304 stainless steel
- Female pipe threads
- Wrench flats on shank

Ordering Information

Description	Part Number	A in. (mm)	B in. (mm)	Shipping Weight lbs (kg)	
NW16	1/8 NPT	KAFP160125S	1.04 (26.42)	0.75 (19.05)	1.0 (0.5)
	1/4 NPT	KAFP160250S	1.04 (26.42)	0.75 (19.05)	1.0 (0.5)
	3/8 NPT	KAFP160375S	1.04 (26.42)	0.88 (22.23)	1.0 (0.5)
NW25	1/8 NPT	KAFP250125S	1.04 (26.42)	0.75 (19.05)	1.0 (0.5)
	1/4 NPT	KAFP250250S	1.04 (26.42)	0.75 (19.05)	1.0 (0.5)
	3/8 NPT	KAFP250375S	1.04 (26.42)	0.88 (22.23)	1.0 (0.5)
	1/2 NPT	KAFP250500S	1.04 (26.42)	1.13 (28.58)	1.0 (0.5)
NW40	1/8 NPT	KAFP400125S	1.04 (26.42)	0.75 (19.05)	1.0 (0.5)
	1/4 NPT	KAFP400250S	1.04 (26.42)	0.75 (19.05)	1.0 (0.5)
	3/8 NPT	KAFP400375S	1.04 (26.42)	0.88 (22.23)	1.0 (0.5)
	1/2 NPT	KAFP400500S	1.65 (41.91)	1.13 (28.58)	1.0 (0.5)
	3/4 NPT	KAFP400750S	1.65 (41.91)	1.25 (31.75)	1.0 (0.5)
	1NPT	KAFP401000S	1.65 (41.91)	1.56 (39.67)	1.0 (0.5)

VACUUM COMPONENTS

▶ Aluminum Female Pipe Adapters NW16 – NW40 (ISO)

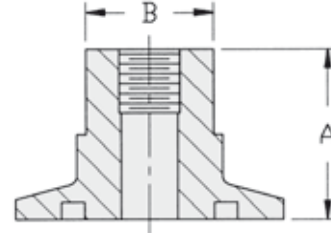

Specifications

- 6061 T6 aluminum
- Female pipe threads
- Wrench flats on shank

Ordering Information

Description	Part Number	A in. (mm)	B in. (mm)	Shipping Weight lbs (kg)	
NW16	1/8 NPT	KAFP160125A	1.04 (26.42)	0.75 (19.05)	1.0 (0.5)
	1/4 NPT	KAFP160250A	1.04 (26.42)	0.75 (19.05)	1.0 (0.5)
	3/8 NPT	KAFP160375A	1.04 (26.42)	0.88 (22.23)	1.0 (0.5)
NW25	1/8 NPT	KAFP250125A	1.04 (26.42)	0.75 (19.05)	1.0 (0.5)
	1/4 NPT	KAFP250250A	1.04 (26.42)	0.75 (19.05)	1.0 (0.5)
	3/8 NPT	KAFP250375A	1.04 (26.42)	0.88 (22.23)	1.0 (0.5)
	1/2 NPT	KAFP250500A	1.04 (26.42)	1.13 (28.58)	1.0 (0.5)
NW40	1/8 NPT	KAFP400125A	1.04 (26.42)	0.75 (19.05)	1.0 (0.5)
	1/4 NPT	KAFP400250A	1.04 (26.42)	0.75 (19.05)	1.0 (0.5)
	3/8 NPT	KAFP400375A	1.04 (26.42)	0.88 (22.23)	1.0 (0.5)
	1/2 NPT	KAFP400500A	1.65 (41.91)	1.13 (28.58)	1.0 (0.5)
	3/4 NPT	KAFP400750A	1.65 (41.91)	1.25 (31.75)	1.0 (0.5)
	1NPT	KAFP401000A	1.65 (41.91)	1.56 (39.67)	1.0 (0.5)

KLAMPS FLANGES & FITTINGS

► Flexible Couplings (Non-Braided)

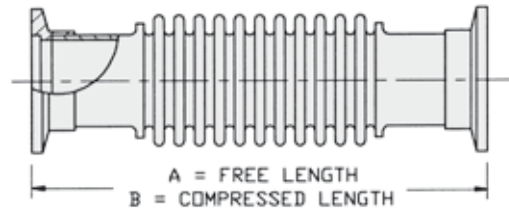
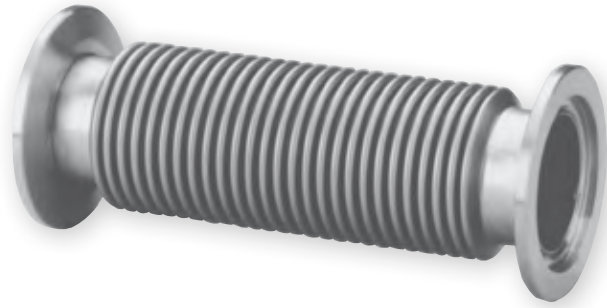

Specifications

- Stainless steel
- Full penetration vacuum weld

Ordering Information

Flange Size	Part Number	Length		Static Bend Radius in. (mm)	Bellows Wall Thickness in.	Nominal ID in. (mm)	Shipping Weight lbs (kg)
		A in. (mm)	B in. (mm)				
NW16	KL00750315	3.2 (81)	2.9 (75)	3.0 (76)	0.006	0.75 (19.1)	1.0 (0.5)
	KL00750394	3.9 (100)	3.7 (93)	3.0 (76)	0.006	0.75 (19.1)	1.0 (0.5)
	KL00750984	9.8 (250)	9.0 (228)	3.0 (76)	0.006	0.75 (19.1)	1.5 (0.7)
	KL00751969	19.7 (500)	17.8 (453)	1.3 (33)	0.008	0.75 (19.1)	3.0 (1.4)
	KL00753940	39.4 (1000)	35.6 (903)	1.3 (33)	0.008	0.75 (19.1)	4.0 (1.8)
	KL00754800	48.0 (1219)	43.3 (1100)	1.3 (33)	0.008	0.75 (19.1)	5.0 (2.3)
NW25	KL01000394	3.9 (100)	3.6 (92)	4.0 (102)	0.006	1.00 (25.4)	1.0 (0.5)
	KL01000984	9.8 (250)	8.9 (227)	4.0 (102)	0.006	1.00 (25.4)	1.0 (0.5)
	KL01001969	19.7 (500)	17.8 (452)	1.5 (38)	0.008	1.00 (25.4)	3.0 (1.4)
	KL01002400	24.0 (609)	21.7 (551)	1.5 (38)	0.008	1.00 (25.4)	3.0 (1.4)
	KL01003940	39.4 (1000)	35.5 (903)	1.5 (38)	0.008	1.00 (25.4)	4.0 (1.8)
	KL01004800	48.0 (1219)	43.3 (1100)	1.5 (38)	0.008	1.00 (25.4)	5.0 (2.3)
NW40	KL01500394	3.9 (100)	3.6 (92)	6.0 (152)	0.006	1.38 (35.1)	1.0 (0.5)
	KL01500512	5.1 (130)	4.7 (119)	6.0 (152)	0.006	1.50 (38.1)	1.5 (0.7)
	KL01500984	9.8 (250)	8.9 (227)	6.0 (152)	0.006	1.50 (38.1)	2.0 (0.9)
	KL01501200	12.0 (305)	10.9 (276)	6.0 (152)	0.006	1.50 (38.1)	2.5 (1.1)
	KL01501969	19.7 (500)	17.8 (452)	2.2 (56)	0.010	1.50 (38.1)	3.0 (1.4)
	KL01502400	24.0 (609)	21.7 (551)	2.2 (56)	0.010	1.50 (38.1)	3.5 (1.6)
	KL01503940	39.4 (1000)	35.5 (903)	2.2 (56)	0.010	1.50 (38.1)	4.0 (1.8)
	KL01504800	48.0 (1219)	43.3 (1100)	2.2 (56)	0.010	1.50 (38.1)	5.0 (2.3)
NW50	KL02000394	3.9 (100)	3.7 (93)	6.0 (152)	0.006	1.88 (47.8)	1.0 (0.5)
	KL02000551	5.5 (140)	5.1 (129)	7.5 (191)	0.006	2.00 (50.8)	1.5 (0.7)
	KL02000984	9.8 (250)	9.0 (228)	7.5 (191)	0.006	2.00 (50.8)	2.0 (0.9)
	KL02001969	19.7 (500)	17.8 (453)	2.6 (66)	0.012	2.00 (50.8)	3.0 (1.4)
	KL02003940	39.4 (1000)	35.6 (903)	2.6 (66)	0.012	2.00 (50.8)	4.0 (1.8)
	KL02004800	48.0 (1219)	43.3 (1100)	2.6 (66)	0.012	2.00 (50.8)	5.0 (2.3)

VACUUM COMPONENTS

► Flexible Couplings (Braided)

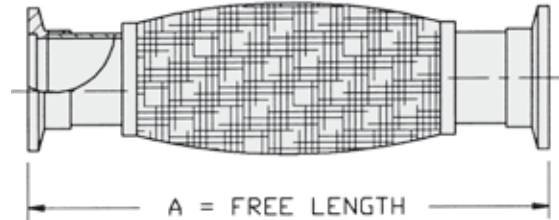
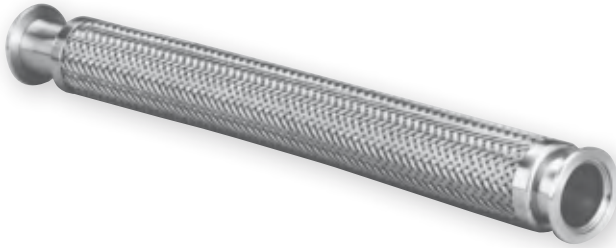

Specifications

- Stainless steel
- Braided sheathing
- Full penetration vacuum weld

Ordering Information

Flange Size	Part Number	Length Free A in. (mm)	Static Bend Radius in. (mm)	Bellows Wall Thickness in.	Nominal ID in. (mm)	Shipping Weight lbs (kg)
NW16	KLB00751200	12.0 (305)	2.1 (53)	0.008	0.75 (19.1)	2.0 (0.9)
	KLB00751850	18.5 (470)	2.1 (53)	0.008	0.75 (19.1)	2.0 (0.9)
	KLB00752400	24.0 (610)	2.1 (53)	0.008	0.75 (19.1)	3.0 (1.4)
	KLB00753600	36.0 (914)	2.1 (53)	0.008	0.75 (19.1)	4.0 (1.8)
	KLB00754000	40.0 (1016)	2.1 (53)	0.008	0.75 (19.1)	5.0 (2.3)
	KLB00754800	48.0 (1219)	2.1 (53)	0.008	0.75 (19.1)	5.0 (2.3)
NW25	KLB01001000	10.0 (254)	2.5 (64)	0.008	1.00 (25.4)	3.0 (1.4)
	KLB01001200	12.0 (305)	2.5 (64)	0.008	1.00 (25.4)	3.0 (1.4)
	KLB01001850	18.5 (470)	2.5 (64)	0.008	1.00 (25.4)	3.0 (1.4)
	KLB01002000	20.0 (508)	2.5 (64)	0.008	1.00 (25.4)	3.0 (1.4)
	KLB01002400	24.0 (610)	2.5 (64)	0.008	1.00 (25.4)	3.0 (1.4)
	KLB01003600	36.0 (914)	2.5 (64)	0.008	1.00 (25.4)	4.0 (1.8)
	KLB01004000	40.0 (1016)	2.5 (64)	0.008	1.00 (25.4)	5.0 (2.3)
	KLB01004800	48.0 (1219)	2.5 (64)	0.008	1.00 (25.4)	5.0 (2.3)
NW40	KLB01501000	10.0 (254)	3.9 (99)	0.010	1.50 (38.1)	4.0 (1.8)
	KLB01501200	12.0 (305)	3.9 (99)	0.010	1.50 (38.1)	4.0 (1.8)
	KLB01501850	18.5 (470)	3.9 (99)	0.010	1.50 (38.1)	4.0 (1.8)
	KLB01502000	20.0 (508)	3.9 (99)	0.010	1.50 (38.1)	4.0 (1.8)
	KLB01502400	24.0 (610)	3.9 (99)	0.010	1.50 (38.1)	4.5 (2.1)
	KLB01503600	36.0 (914)	3.9 (99)	0.010	1.50 (38.1)	4.5 (2.1)
	KLB01504000	40.0 (1016)	3.9 (99)	0.010	1.50 (38.1)	5.0 (2.3)
	KLB01504800	48.0 (1219)	3.9 (99)	0.010	1.50 (38.1)	5.0 (2.3)
NW50	KLB02002400	24.0 (610)	4.7 (120)	0.012	2.00 (50.8)	6.0 (2.7)
	KLB02003600	36.0 (914)	4.7 (120)	0.012	2.00 (50.8)	7.0 (3.2)
	KLB02004000	40.0 (1016)	4.7 (120)	0.012	2.00 (50.8)	7.0 (3.2)
	KLB02004800	48.0 (1219)	4.7 (120)	0.012	2.00 (50.8)	8.0 (3.6)

KLAMPS FLANGES & FITTINGS

► KF to Compression Port Adapters

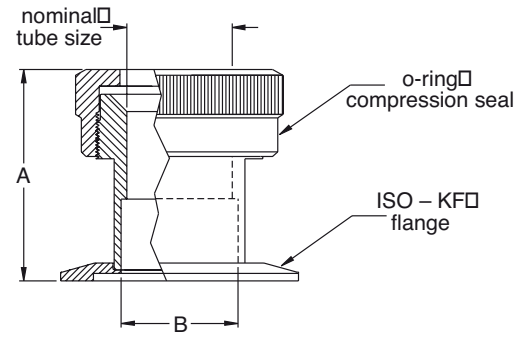

Figure 1

Specifications

- 304 stainless steel
- Knurled nut for hand-tightening
- ISO-KF Flanges
- Use for standard inch size tubulation

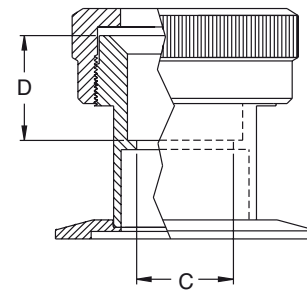

Figure 2

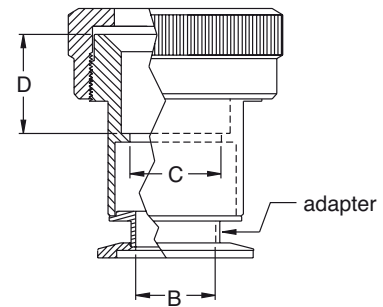

Figure 3

VACUUM COMPONENTS

Ordering Information

Flange Size	Part Number	Nominal Tube Size	Length		Bore		ID C in. (mm)	Tube Stop D in. (mm)	Fig.	Weight lbs (kg)
			A in. (mm)	B in. (mm)	B in. (mm)	B in. (mm)				
NW16	KCP160125	1/8 in.	1.65 (41.91)	0.63 (16.00)	0.63 (16.00)	0.63 (16.00)	—	—	1	1.0 (0.5)
	KCP160190	3/16 in.	1.65 (41.91)	0.63 (16.00)	0.63 (16.00)	0.63 (16.00)	—	—	1	1.0 (0.5)
	KCP160250	1/4 in.	1.65 (41.91)	0.63 (16.00)	0.63 (16.00)	0.63 (16.00)	—	—	1	1.0 (0.5)
	KCP160375	3/8 in.	1.65 (41.91)	0.63 (16.00)	0.63 (16.00)	0.63 (16.00)	—	—	1	1.0 (0.5)
	KCP160500	1/2 in.	1.65 (41.91)	0.63 (16.00)	0.63 (16.00)	0.63 (16.00)	—	—	1	1.0 (0.5)
	KCP160625	5/8 in.	1.65 (41.91)	0.63 (16.00)	0.63 (16.00)	0.63 (16.00)	—	—	1	1.0 (0.5)
NW25	KCP250062	1/16 in.	1.65 (41.91)	0.63 (16.00)	0.63 (16.00)	0.63 (16.00)	—	—	1	1.0 (0.5)
	KCP250125	1/8 in.	1.65 (41.91)	0.63 (16.00)	0.63 (16.00)	0.63 (16.00)	—	—	1	1.0 (0.5)
	KCP250190	3/16 in.	1.65 (41.91)	0.63 (16.00)	0.63 (16.00)	0.63 (16.00)	—	—	1	1.0 (0.5)
	KCP250250	1/4 in.	1.65 (41.91)	0.63 (16.00)	0.63 (16.00)	0.63 (16.00)	—	—	1	1.0 (0.5)
	KCP250312	5/16 in.	1.65 (41.91)	0.63 (16.00)	0.63 (16.00)	0.63 (16.00)	—	—	1	1.0 (0.5)
	KCP250375	3/8 in.	1.65 (41.91)	0.63 (16.00)	0.63 (16.00)	0.63 (16.00)	—	—	1	1.0 (0.5)
	KCP250500	1/2 in.	1.65 (41.91)	0.63 (16.00)	0.63 (16.00)	0.63 (16.00)	—	—	1	1.0 (0.5)
	KCP250625	5/8 in.	1.65 (41.91)	0.63 (16.00)	0.63 (16.00)	0.63 (16.00)	—	—	1	1.0 (0.5)
	KCP250750	3/4 in.	2.37 (60.20)	0.90 (22.86)	0.90 (22.86)	0.63 (16.0)	1.13 (28.7)	3	1.0 (0.5)	
NW40	KCP400125	1/8 in.	1.65 (41.91)	0.63 (16.00)	0.63 (16.00)	0.63 (16.00)	—	—	1	2.0 (0.9)
	KCP400250	1/4 in.	1.65 (41.91)	0.63 (16.00)	0.63 (16.00)	0.63 (16.00)	—	—	1	2.0 (0.9)
	KCP400375	3/8 in.	1.65 (41.91)	0.63 (16.00)	0.63 (16.00)	0.63 (16.00)	—	—	1	2.0 (0.9)
	KCP400500	1/2 in.	1.65 (41.91)	0.63 (16.00)	0.63 (16.00)	0.63 (16.00)	—	—	1	2.0 (0.9)
	KCP400625	5/8 in.	1.65 (41.91)	0.63 (16.00)	0.63 (16.00)	0.63 (16.00)	—	—	1	2.0 (0.9)
	KCP400750	3/4 in.	2.02 (51.31)	1.38 (35.05)	1.38 (35.05)	0.63 (16.00)	—	—	1	2.0 (0.9)
	KCP400880	7/8 in.	2.02 (51.31)	1.38 (35.05)	1.38 (35.05)	0.63 (16.00)	—	—	1	2.0 (0.9)
	KCP401000	1 in.	2.02 (51.31)	1.38 (35.05)	1.38 (35.05)	0.88 (22.4)	1.13 (28.7)	2	2.0 (0.9)	
	KCP401125	1 1/8 in.	2.02 (51.31)	1.38 (35.05)	1.38 (35.05)	0.63 (16.00)	—	—	1	2.0 (0.9)
	KCP401250	1 1/4 in.	2.02 (51.31)	1.38 (35.05)	1.38 (35.05)	0.63 (16.00)	—	—	1	2.0 (0.9)

KLAMPS FLANGES & FITTINGS

► Adapters: KF to Swagelok

NOTE • KF flanges are 304L stainless steel



Ordering Information

Flange Size	Tube Size	Part Number	Length in. (mm)	Shipping Weight lbs (kg)
NW16	¼ in.	KASW025016	1.47 (37.3)	0.2 (0.11)
NW25	¼ in.	KASW025025	1.47 (37.3)	0.2 (0.11)
NW40	¼ in.	KASW025040	1.47 (37.3)	0.2 (0.11)
NW50	¼ in.	KASW025050	1.47 (37.3)	0.2 (0.11)
NW16	⅜ in.	KASW037516	1.63 (41.4)	0.2 (0.11)
NW25	⅜ in.	KASW037525	1.63 (41.4)	0.2 (0.11)
NW40	⅜ in.	KASW037540	1.63 (41.4)	0.2 (0.11)
NW50	⅜ in.	KASW037550	1.63 (41.4)	0.2 (0.11)
NW16	½ in.	KASW050016	1.77 (45.0)	0.2 (0.11)
NW25	½ in.	KASW050025	1.77 (45.0)	0.2 (0.11)
NW40	½ in.	KASW050040	1.77 (45.0)	0.5 (0.22)
NW50	½ in.	KASW050050	1.77 (45.0)	0.5 (0.22)
NW40	½ in.	KASW075040	2.14 (54.4)	0.5 (0.22)
NW50	½ in.	KASW075050	2.14 (54.4)	0.5 (0.22)
NW40	1 in.	KASW100040	2.60 (66.0)	0.5 (0.22)

VACUUM COMPONENTS

▶ Adapters: KF to VCR – Male & Female

NOTE • KF flanges are 304L stainless steel



Ordering Information

Flange Size	Tube Size	Part Number	Length in. (mm)	Shipping Weight lbs (kg)
Male				
NW16	¼ in.	KAVM025016	1.46 (37.1)	0.2 (0.11)
NW25	¼ in.	KAVM025025	1.46 (37.1)	0.2 (0.11)
NW40	¼ in.	KAVM025040	1.46 (37.1)	0.2 (0.11)
NW16	½ in.	KAVM050016	1.65 (41.9)	0.2 (0.11)
NW25	½ in.	KAVM050025	1.65 (41.9)	0.2 (0.11)
NW40	½ in.	KAVM050040	1.65 (41.9)	0.5 (0.22)
NW25	¾ in.	KAVM075025	2.15 (54.6)	0.2 (0.11)
Female				
NW16	¼ in.	KAVF025016	1.46 (37.1)	0.2 (0.11)
NW25	¼ in.	KAVF025025	1.46 (37.1)	0.2 (0.11)
NW40	¼ in.	KAVF025040	1.46 (37.1)	0.2 (0.11)
NW16	½ in.	KAVF050016	1.65 (41.9)	0.2 (0.11)
NW25	½ in.	KAVF050025	1.65 (41.9)	0.2 (0.11)
NW40	½ in.	KAVF050040	1.65 (41.9)	0.5 (0.22)
NW16	¾ in.	KAVF075016	2.15 (54.6)	0.2 (0.11)
NW25	¾ in.	KAVF075025	2.15 (54.6)	0.2 (0.11)

KLAMPS FLANGES & FITTINGS

▶ PVC Cord-Reinforced Flexible Vacuum Hose



Features

- Lightweight
- Transparent
- Smooth surface inside and out

Technical Specifications

Vacuum Range

To 1×10^7

Temperature Range

-25 °C to 45 °C

Ordering Information

Part Number	I.D. in.	O.D. in.	Weight lbs (kg)
Flexible Vacuum Hose			
HFP075	0.75	1.00	0.2 (0.11)
HFP100	1.00	1.25	0.2 (0.11)
HFP125	1.25	1.62	0.2 (0.11)
HFP150	1.50	1.87	0.2 (0.11)
HFP200	2.00	2.50	0.2 (0.11)

Part Number	Size Range	Weight lbs (kg)
Steel Worm Gear Hose Clamps		
HFPC056	$\frac{9}{16}$ in. to $1\frac{1}{4}$ in.	0.5 (0.22)
HFPC075	$\frac{3}{4}$ in. to $1\frac{3}{4}$ in.	0.5 (0.22)
HFPC131	$1\frac{5}{16}$ in. to $2\frac{1}{4}$ in.	0.5 (0.22)
HFPC156	$1\frac{9}{16}$ in. to $2\frac{1}{2}$ in.	0.5 (0.22)

- NOTE**
- 10 per package
 - Use *Weld Stubs* (page 52) with this hose for correct fit

▶ Aluminum Male Rubber Hose Adapter

- NOTE**
- not intended for use with the PVC Cord-Reinforced Flexible Vacuum Hose; suitable for use with rubber hose.

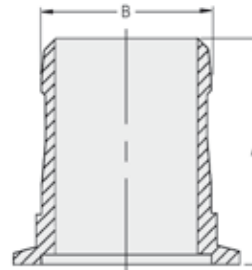

Ordering Information

Flange Size	Hose Size in.	Part Number	A in.	B in.	Weight lbs (kg)
NW16	0.50 – 0.62	KAH16050A	1.65	0.625	0.5 (0.11)
NW16	0.62 – 0.75	KAH16075A	1.65	0.750	0.5 (0.11)
NW25	0.75 – 0.87	KAH25075A	1.73	0.875	0.5 (0.11)
NW40	1.50 – 1.62	KAH40150A	2.17	1.630	0.5 (0.11)
NW50	1.50 – 1.62	KAH50150A	2.17	1.630	0.5 (0.11)

ISO FLANGES & FITTINGS

Agilent's introduction of its extensive offering in vacuum flanges and fittings features an intuitive part numbering format. This part numbering format allows the customer to identify the product by the characters contained within the part number.

Depending on the product, the number and format of the characters in the part number will vary.

Please see examples below:

ISO Flange Example

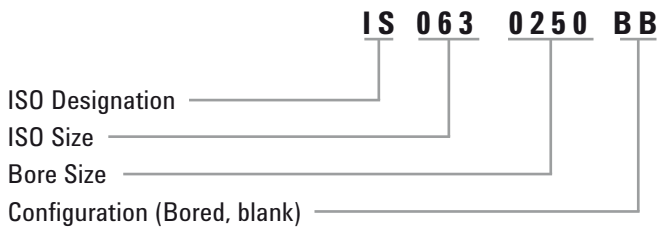

ISO 80 to 63

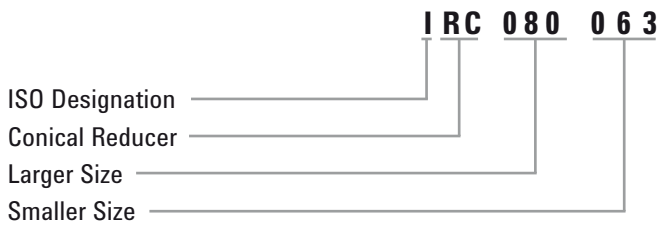

VACUUM COMPONENTS

ISO flanges and fittings are designed for applications requiring frequent disassembly and where tubing requirements generally exceed 2 in. OD. All ISO flanges and fittings listed are made of 304L stainless steel. These flanges can be used in a variety of applications from atmospheric to E⁻⁸ Torr. They can sustain a bakeout temperature of 150 °C when using Viton o-rings.

ISO-Flanges & Fittings

Page

Flange Fastening Options	72
MF Flanges.....	73
Bolted Flanges.....	74
Bolt Sets.....	74
Bolted Tapped Flanges	75
Bolt Sets for Tapped Flanges.....	75
Centering Rings.....	76
Clamps	77
O-Rings	79
Weld Stubs.....	80
Half Nipples	81
Nipples.....	81
Elbows.....	82
Tees.....	82
4-Way Cross.....	83
Reducing Nipple	83
Flexible Couplings.....	84
Conical Reducers	85
Adapters, ISO to ConFlat.....	86
Adapters, ISO to KF	87

ISO FLANGES & FITTINGS

► Flange Fastening Options

Flanges are available in these bolting/clamping options:
Clamped Flanges (also called MF Flanges or Multi-Fastener) are fastened to each other with Double-Claw Clamps (Fig. 1), or to bolted tapped flanges with Single-Claw Clamps (Fig. 2). Bolted Flanges may be fastened to each other with Nut/Bolt Sets (Fig. 3), or bolted to ISO Bolted Tapped Flanges (Fig. 4).

NOTE • At 10" (NW250) and above, some manufacturers standards vary. Please check dimensions carefully.

Flange Fastening Options

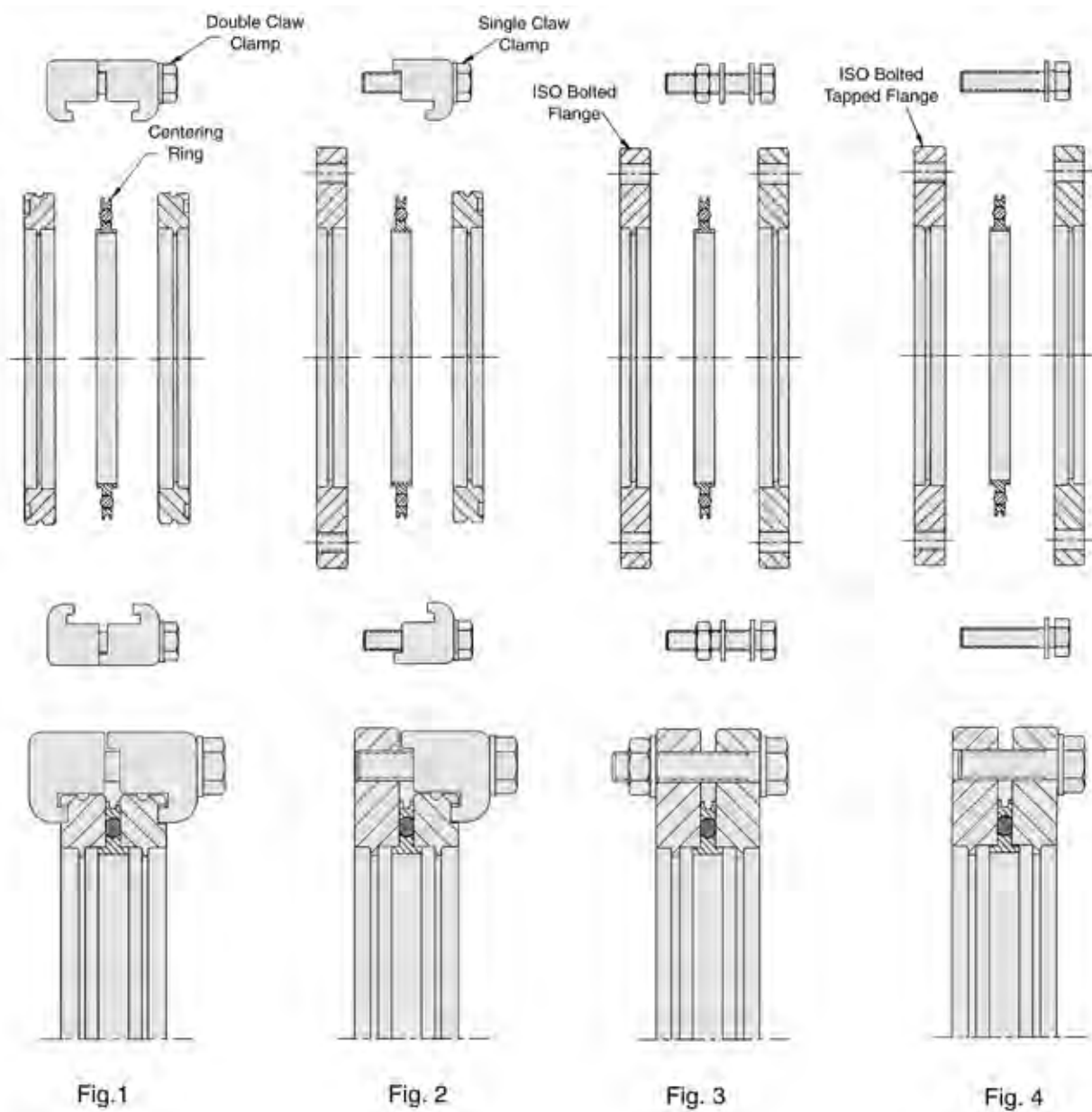

VACUUM COMPONENTS

▶ MF Flanges-Bored

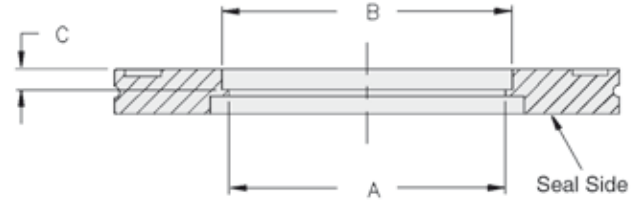

Ordering Information

Size	Part Number	Nominal Bore	A in. (mm)	B in. (mm)	C in. (mm)	Shipping Weight lbs (kg)
NW63	IS0630250BB	2.5 in.	2.37 (60.2)	2.53 (63.8)	0.22 (5.6)	1.0 (0.5)
NW100	IS1000400BB	4.0 in.	3.84 (97.5)	4.03 (101.9)	0.22 (5.6)	1.0 (0.5)
NW160	IS1600600BB	6.0 in.	5.85 (148.6)	6.03 (152.7)	0.22 (5.6)	2.0 (0.9)
NW200	IS2000800BB	8.0 in.	7.85 (199.4)	8.03 (203.5)	0.22 (5.6)	3.0 (1.4)
NW250	IS2501000BB	10.0 in.	9.86 (250.4)	10.04 (254.3)	0.22 (5.6)	4.0 (1.8)

▶ MF Flanges-Blank

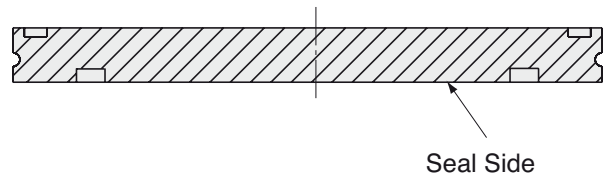

Ordering Information

Size	Part Number	Outer Diameter	Thickness	Shipping Weight lbs (kg)
NW63	IS0630000BL	3.74 (95.0)	0.47 (12.0)	1.0 (0.5)
NW100	IS1000000BL	5.12 (130.0)	0.47 (12.0)	2.5 (1.1)
NW160	IS1600000BL	7.09 (180.0)	0.47 (12.0)	5.0 (2.3)
NW200	IS2000000BL	9.45 (240.0)	0.47 (12.0)	8.0 (3.6)
NW250	IS2500000BL	11.42 (290.0)	0.47 (12.0)	13.0 (5.9)

ISO FLANGES & FITTINGS

▶ Bolted Clear Hole Flanges

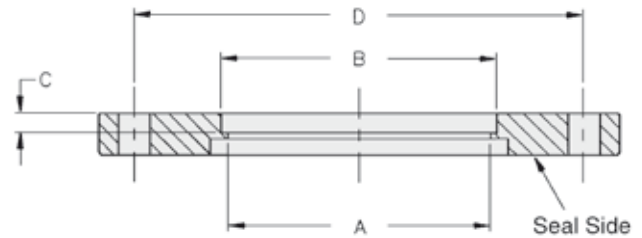

Ordering Information – Bolted Flanges-Bored

Size	Part Number	Nominal Bore	A in. (mm)	B in. (mm)	C in. (mm)	D in. (mm)	Bolt Holes	Weight lbs (kg)
NW63	IS0630250BBB	2.5 in.	2.37 (60.2)	2.53 (63.8)	0.22 (5.6)	4.33 (110.0)	4 x M9	0.50 (0.2)
NW100	IS1000400BBB	4.0 in.	3.83 (97.5)	4.03 (101.9)	0.22 (5.6)	5.71 (145.0)	8 x M9	1.00 (0.5)
NW160	IS1600600BBB	6.0 in.	5.83 (148.6)	6.03 (152.7)	0.22 (5.6)	7.87 (200.0)	8 x M11	1.50 (0.7)
NW250	IS2501000BBB	10.0 in.	9.76 (250.4)	10.04 (254.3)	0.22 (5.6)	12.20 (310.0)	12 x M11	3.00 (1.4)

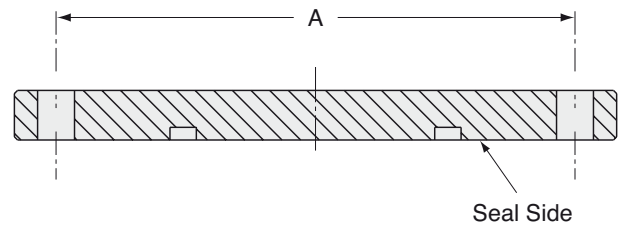

Ordering Information – Bolted Flanges-Blank

Size	Part Number	A in. (mm)	Bolt Holes	Shipping Weight lbs (kg)
NW100	IS1000000BLB	5.71 (145.0)	8 x M9	2.5 (1.1)
NW160	IS1600000BLB	7.87 (199.9)	8 x M11	5.0 (2.3)
NW250	IS2500000BLB	12.20 (309.9)	12 x M11	13.0 (5.9)

▶ Bolt Sets for Clear Hole Flanges

Ordering Information

Size	Part Number	Bolt Size	Qty/Pack	Shipping Weight lbs (kg)
NW160	IB160	M10 x 50 mm	8	0.50 (0.2)
NW200, NW250	IB200250	M10 x 50 mm	12	0.75 (0.3)

VACUUM COMPONENTS

▶ Bolted Tapped Flanges

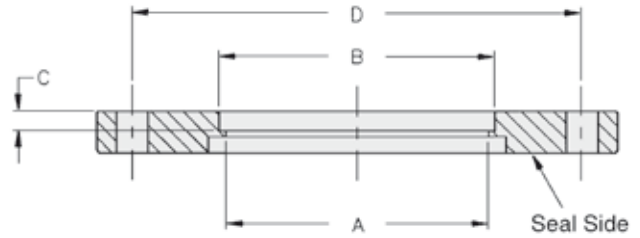

Ordering Information

Size	Part Number	Nominal Bore	A in. (mm)	B in. (mm)	C in. (mm)	D in. (mm)	Bolt Holes	Weight lbs (kg)
NW63	IS0630250BBBT	2.5 in.	2.37 (60.2)	2.53 (63.8)	0.22 (5.6)	4.33 (110.0)	4 x M8	0.50 (0.2)
NW100	IS1000400BBBT	4.0 in.	3.83 (97.5)	4.03 (101.9)	0.22 (5.6)	5.71 (145.0)	8 x M8	1.00 (0.5)
NW200	IS2000800BBBT	8.0 in.	7.83 (199.4)	8.03 (203.5)	0.22 (5.6)	10.24 (260.0)	12 x M10	2.00 (0.9)
NW250	IS2501000BBBT	10.0 in.	9.76 (250.4)	10.04 (254.3)	0.22 (5.6)	12.20 (310.0)	12 x M10	3.00 (1.4)

▶ Bolt Sets for Tapped Flanges

Ordering Information

Size	Part Number	Bolt Size	Qty/Pack	Shipping Weight lbs (kg)
NW80, NW100	IB080100T	M8 x 30 mm	8	0.50 (0.2)
NW200, NW250	IB200250T	M10 x 35 mm	12	0.75 (0.3)

ISO FLANGES & FITTINGS

► Centering Rings



Ordering Information – Aluminum Ring, Viton O-Ring

Size	Part Number	A in. (mm)	B in. (mm)	Shipping Weight lbs (kg)
NW63	IC063AV	2.62 (66.8)	0.15 (3.8)	1.0 (0.5)
NW80	IC080AV	3.13 (79.8)	0.15 (3.8)	1.0 (0.5)
NW100	IC100AV	3.88 (98.8)	0.15 (3.8)	1.0 (0.5)
NW160	IC160AV	5.87 (149.9)	0.15 (3.8)	1.0 (0.5)
NW200	IC200AV	8.24 (209.8)	0.15 (3.8)	1.0 (0.5)
NW250	IC250AV	10.13 (257.6)	0.15 (3.8)	1.0 (0.5)

Ordering Information – Aluminum Ring, Buna-N O-Ring

Size	Part Number	A in. (mm)	B in. (mm)	Shipping Weight lbs (kg)
NW63	IC063AB	2.62 (66.8)	0.15 (3.8)	1.0 (0.5)
NW100	IC100AB	3.88 (98.8)	0.15 (3.8)	1.0 (0.5)
NW160	IC160AB	5.87 (149.9)	0.15 (3.8)	1.0 (0.5)
NW200	IC200AB	8.24 (209.8)	0.15 (3.8)	1.0 (0.5)
NW250	IC250AB	10.13 (257.6)	0.15 (3.8)	1.0 (0.5)

Ordering Information – Stainless Steel Ring, Viton O-Ring

Size	Part Number	A in. (mm)	B in. (mm)	Shipping Weight lbs (kg)
NW63	IC063SV	2.62 (66.8)	0.15 (3.8)	1.0 (0.5)
NW80	IC080SV	3.13 (79.8)	0.15 (3.8)	1.0 (0.5)
NW100	IC100SV	3.88 (98.8)	0.15 (3.8)	1.0 (0.5)
NW160	IC160SV	5.87 (149.9)	0.15 (3.8)	1.0 (0.5)
NW200	IC200SV	8.24 (209.8)	0.15 (3.8)	1.0 (0.5)
NW250	IC250SV	10.13 (257.6)	0.15 (3.8)	1.0 (0.5)

VACUUM COMPONENTS

▶ Modified ISO Claw Clamps

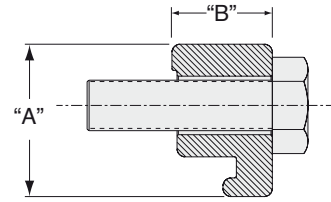
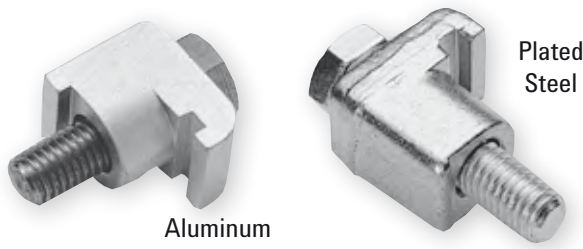

Figure 1

Features

- Heavy duty material
- Suitable for mounting equipment in any orientation and tight geometrics

Ordering Information – Single Claw Clamp – For use with a Standard ISO Flange and Centering Ring (NOT for Turbo Pumps)

Size	Figure	Part Number	Per Package	A in. (mm)	B in. (mm)	Bolt Size	Shipping Weight lbs (kg)
NW63/100	1	ICS063100CC22X5S	4	0.925 (23.5)	0.87 (22.5)	M8 x 35 mm	1.0 (0.50)
NW160/250	1	ICS160250CC23X0A*	1	1.126 (28.6)	0.91 (23.1)	M10 x 35 mm	0.5 (0.20)

* Aluminum

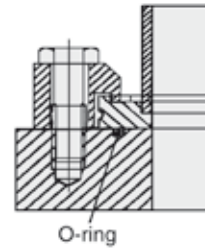
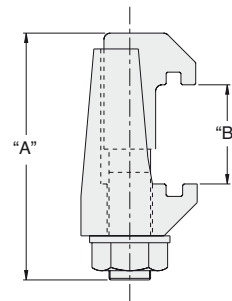
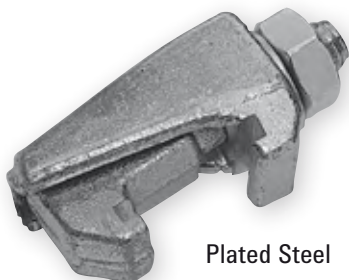

Figure 2

Ordering Information – Single Claw Clamp – For use with a Flange and Base Plate with Sealing Groove and O-ring (NOT for Turbo Pumps)

Size	Figure	Part Number	Per Package	A in. (mm)	B in. (mm)	Bolt Size	Shipping Weight lbs (kg)
NW160/250	1 & 2	ICS160250CC19X1S	1 & 2	1.14 (28.8)	.75 (19.1)	M10 x 35 mm	1.0 (0.5)



Ordering Information – Tapered Claw Clamp, ISO 63/250 (Suitable for Agilent Turbo Pumps)

Size	Part Number	A in. (mm)	B in. (mm)	Bolt Size	Shipping Weight lbs (kg)
NW63/250	IC63250DCMZ	2.34 (59.5)	0.67/1.05 (17.0/27)	M10	1.0 (0.5)

ISO FLANGES & FITTINGS

▶ Standard ISO Claw Clamps

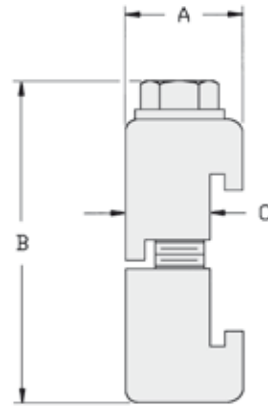

Ordering Information – Double Claw (NOT for Turbo Pumps)

Size	Part Number	A in. (mm)	B in. (mm)	C in. (mm)	Shipping Weight lbs (kg)
For flange sizes NW63, 080, 100	IC063100A	0.95 (24.1)	1.98 (50.3)	0.63 (16.0)	0.5 (0.2)
For flange sizes NW160, 200, 250	IC160250A	1.10 (27.9)	2.05 (52.1)	0.80 (20.3)	0.5 (0.2)
For flange sizes NW400, 500	IC400500A	1.34 (34.0)	2.56 (65.0)	1.04 (26.4)	0.5 (0.2)

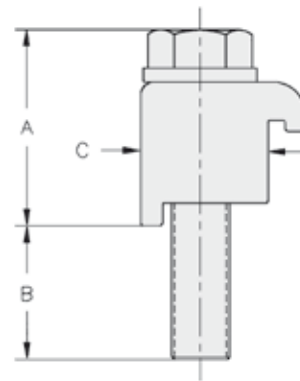
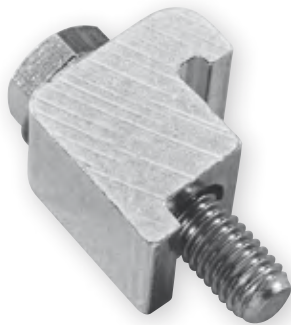

Ordering Information – Single Claw (NOT for Turbo Pumps)

Size	Part Number	A in. (mm)	B in. (mm)	C in. (mm)	Shipping Weight lbs (kg)
For flange sizes NW63, 080, 100	ICS063100A	1.20 (30.4)	0.39 (9.9)	0.63 (16.0)	0.5 (0.2)
For flange sizes NW160, 200, 250	ICS160250A	1.25 (31.7)	0.39 (9.9)	0.80 (20.3)	0.5 (0.2)

NOTE • Use the chart below to determine proper quantities for all clamps on pages 77 and 78.

Flange Size	# of Clamps
NW63	4
NW100-160	8
NW250	12

VACUUM COMPONENTS

▶ O-Rings

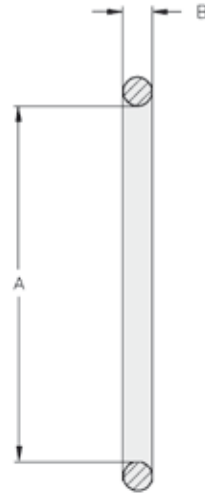

Ordering Information – Viton

Size	Part Number	A in. (mm)	B in. (mm)	Shipping Weight lbs (kg)
NW63	I0063V	2.85 (72.4)	0.21 (5.33)	0.25 (0.1)
NW80	I0080V	3.35 (85.1)	0.21 (5.33)	0.25 (0.1)
NW100	I0100V	4.10 (104.1)	0.21 (5.33)	0.25 (0.1)
NW160	I0160V	5.98 (151.9)	0.21 (5.33)	0.25 (0.1)
NW250	I0250V	10.50 (266.2)	0.21 (5.33)	0.25 (0.1)

Ordering Information – Silicone

Size	Part Number	A in. (mm)	B in. (mm)	Shipping Weight lbs (kg)
NW100	I0100S	4.10 (104.1)	0.21 (5.3)	0.25 (0.1)

ISO FLANGES & FITTINGS

► Weld Stubs

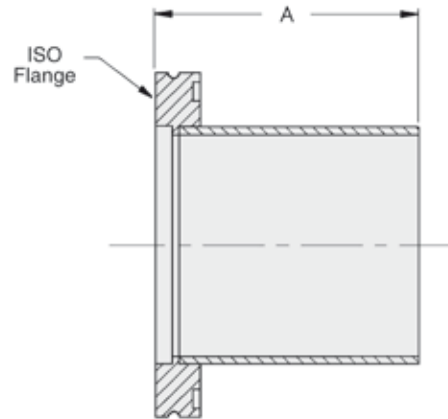

Ordering Information – Weld Stubs, MF Flanges

Size	Part Number	Tube Size	A in. (mm)	Shipping Weight lbs (kg)
NW63	IWS063	2.5 in.	3.94 (100.1)	1.0 (0.5)
NW100	IWS100	4.0 in.	3.94 (100.1)	2.0 (0.9)
NW160	IWS160	6.0 in.	3.94 (100.1)	3.0 (1.4)

Ordering Information – Weld Stubs, Bolted Flanges

Size	Part Number	Tube Size	A in. (mm)	Shipping Weight lbs (kg)
NW160	IWS160B	6.0 in.	3.94 (100.1)	3.0 (1.4)

VACUUM COMPONENTS

▶ Half Nipples

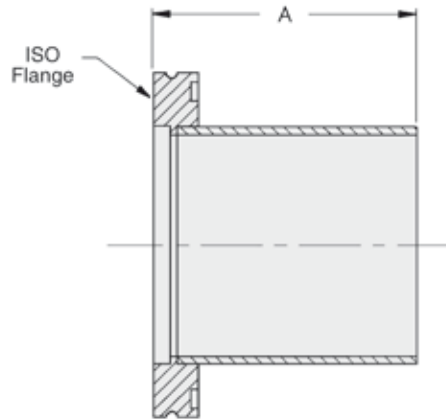

Ordering Information

Size	Part Number	Tube Size	A in. (mm)	Shipping Weight lbs (kg)
NW100	INH1000400	4.0 in.	5.12 (130.0)	2.0 (0.9)
NW160	INH1600600	6.0 in.	6.31 (160.3)	4.0 (1.8)

▶ Nipples

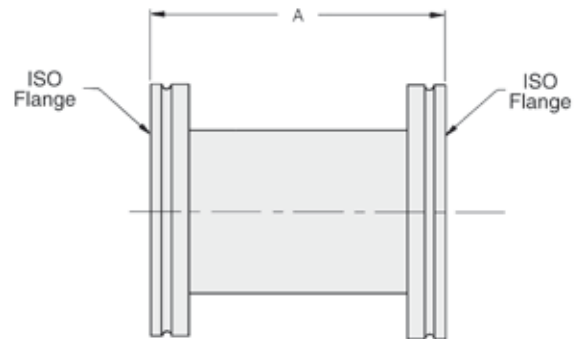

Ordering Information

Size	Part Number	Tube Size	A in. (mm)	Shipping Weight lbs (kg)
NW63	INF0630250	2.5 in.	8.00 (203.2)	2.0 (0.9)
NW100	INF1000400	4.0 in.	10.24 (260.1)	3.0 (1.4)
NW160	INF1600600	6.0 in.	12.62 (320.5)	8.0 (3.6)

ISO FLANGES & FITTINGS

► Elbows 90°

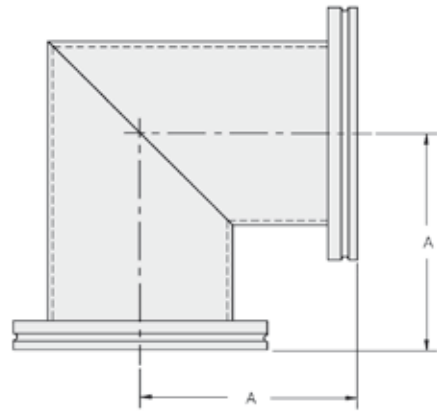

Ordering Information

Size	Part Number	Tube Size	A in. (mm)	Shipping Weight lbs (kg)
NW63	IE02500346	2.5 in.	3.46 (87.9)	2.0 (0.9)
NW100	IE04000425	4.0 in.	4.25 (108.0)	6.0 (2.7)
NW160	IE06000543	6.0 in.	5.43 (137.9)	10.0 (4.5)

► Tees

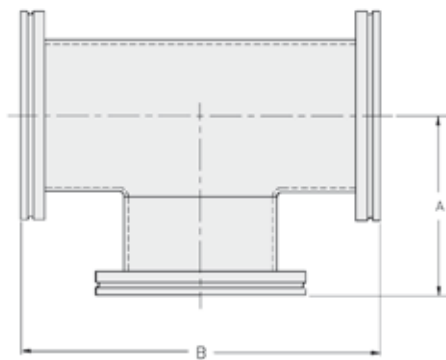

Ordering Information

Size	Part Number	Tube Size	A in. (mm)	B in. (mm)	Shipping Weight lbs (kg)
NW63	IT02500346	2.5 in.	3.46 (87.9)	6.92 (175.8)	3.0 (1.4)
NW100	IT04000425	4.0 in.	4.25 (108.0)	8.50 (215.9)	8.0 (3.6)
NW160	IT06000543	6.0 in.	5.43 (137.9)	10.86 (275.8)	13.0 (5.9)

VACUUM COMPONENTS

► 4-Way Cross

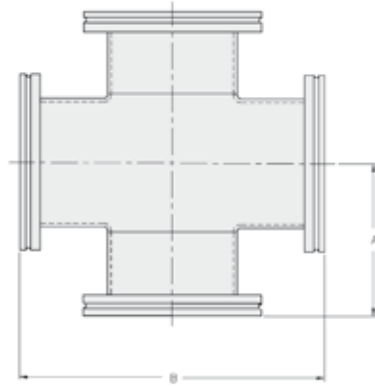

Ordering Information

Size	Part Number	Tube Size	A in. (mm)	B in. (mm)	Shipping Weight lbs (kg)
NW63	IC02500346	2.5 in.	3.46 (87.9)	6.92 (175.8)	6.0 (2.7)
NW100	IC04000425	4.0 in.	4.25 (108.0)	8.50 (215.9)	10.0 (4.5)
NW160	IC06000543	6.0 in.	5.43 (137.9)	10.86 (275.8)	15.0 (6.8)

► Reducing Nipple

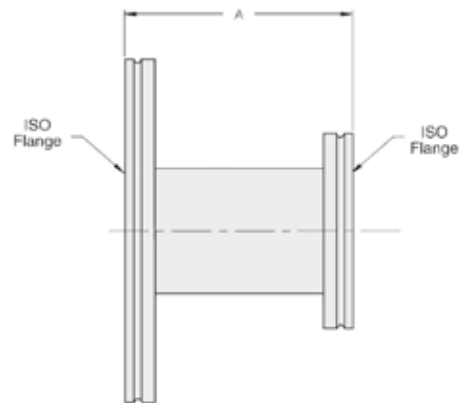

Ordering Information

Size	Part Number	Tube Size	A in. (mm)	Shipping Weight lbs (kg)
NW100-63	INR100063	2.5 in.	4.0 (101.6)	4.5 (2.0)
NW160-63	INR160063	2.5 in.	4.0 (101.6)	6.0 (2.7)
NW160-100	INR160100	4.0 in.	4.0 (101.6)	10.5 (4.8)
NW200-160	INR200160	6.0 in.	4.0 (101.6)	13.5 (6.1)
NW250-200	INR250200	8.0 in.	4.0 (101.6)	18.0 (8.2)

ISO FLANGES & FITTINGS

► Flexible Couplings

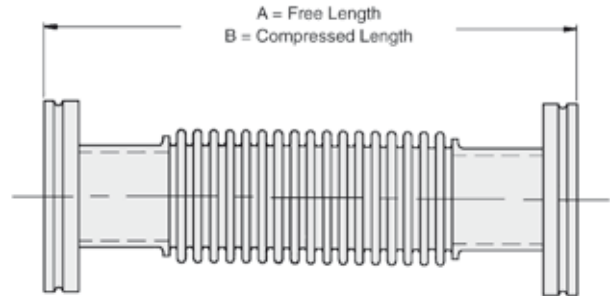

Features

- Bellows Material: Type 321 SS

Ordering Information – Flexible Couplings, Non-Braided, ISO

Flange Size	Part Number	Length		Static Bend Radius in. (mm)	Bellows Wall Thickness in.	Nominal ID in. (mm)	Shipping Weight lbs (kg)
		A in. (mm)	B in. (mm)				
ISO63	IL02000600	6.0 (152)	5.5 (140)	10.0 (254)	0.006	2.5 (64)	2.0 (0.9)
	IL02001200	12.0 (305)	10.9 (277)	10.0 (254)	0.006	2.5 (64)	2.0 (0.9)
	IL02502000	20.0 (508)	18.1 (461)	3.2 (81)	0.015	2.5 (64)	3.0 (1.4)
	IL02503000	30.0 (762)	24.0 (610)	3.2 (81)	0.015	2.5 (64)	3.0 (1.4)
	IL02504000	40.0 (1016)	36.1 (917)	3.2 (81)	0.015	2.5 (64)	4.0 (1.8)
ISO100	IL04000600	6.0 (152)	5.5 (141)	16.0 (406)	0.016	3.5 (89)	3.0 (1.4)
	IL04001200	12.0 (305)	10.9 (277)	19.0 (483)	0.010	4.0 (102)	4.0 (1.8)
	IL04002000	20.0 (508)	18.1 (460)	4.5 (114)	0.016	4.0 (102)	4.0 (1.8)
	IL04003000	30.0 (762)	27.1 (688)	4.5 (114)	0.016	4.0 (102)	5.0 (2.3)
	IL04004000	40.0 (1016)	36.1 (917)	4.5 (114)	0.016	4.0 (102)	5.0 (2.3)
ISO160	IL06000600	6.0 (152)	5.5 (140)	21.0 (533)	0.010	6.0 (152)	4.0 (1.8)
	IL06001200	12.0 (305)	10.9 (277)	21.0 (533)	0.010	6.0 (152)	5.0 (2.3)

VACUUM COMPONENTS

▶ Conical Reducers

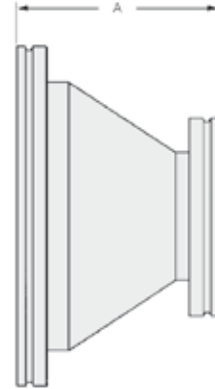

Ordering Information

Size	Part Number	A in. (mm)	Shipping Weight lbs (kg)
NW100-63	IRC100063	4.13 (104.9)	4.5 (2.0)
NW100-80	IRC100080	4.13 (104.9)	4.5 (2.0)
NW160-100	IRC160100	9.50 (241.3)	5.0 (2.3)

▶ Conical Reducers – ISO to KF

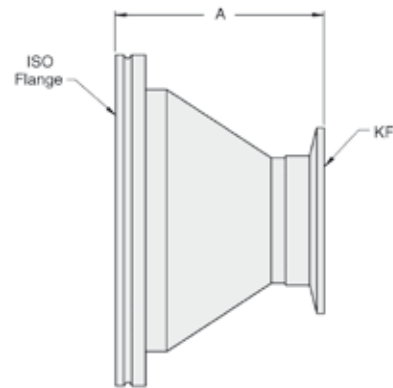

Ordering Information

Size	Part Number	A in. (mm)	Shipping Weight lbs (kg)
NW63-NW40	IKRC063040	2.84 (72.1)	1.5 (0.7)
NW63-NW50	IKRC063050	2.85 (72.4)	2.5 (1.1)
NW80-NW40	IKRC080040	4.09 (103.9)	3.0 (1.4)
NW100-NW50	IKRC100050	4.10 (104.1)	3.5 (1.6)

ISO FLANGES & FITTINGS

▶ Adapters – ISO to ConFlat

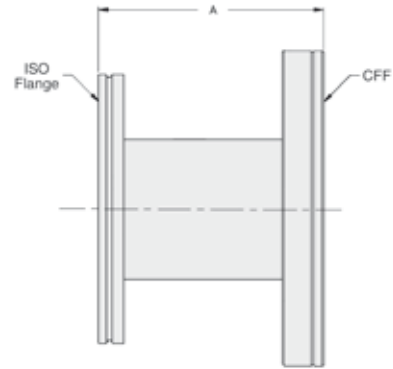
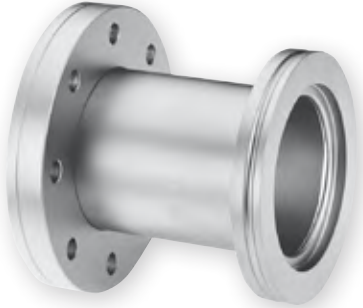

Ordering Information

Size	Part Number	Tube Size	A in. (mm)	Shipping Weight lbs (kg)
NW63-4.5 in. CFF	IFA0630450	2.5 in.	4.13 (104.9)	3.5 (1.6)
NW100-6 in. CFF	IFA1000600	4.0 in.	4.19 (106.4)	5.5 (2.5)
NW160-8 in. CFF	IFA1600800	6.0 in.	4.25 (108.0)	9.0 (4.1)
NW200-10 in. CFF	IFA2001000	8.0 in.	4.25 (108.0)	16.0 (7.2)

VACUUM COMPONENTS

▶ Adapters – ISO to KF, Short and Long

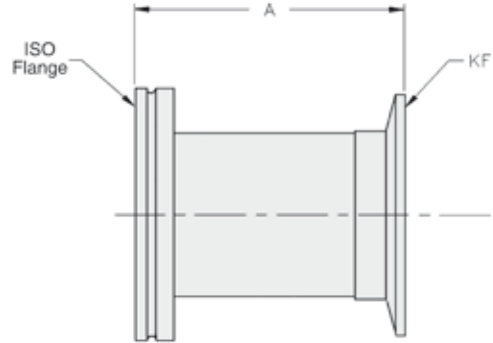

Ordering Information

Size	Part Number	Tube Size	A in. (mm)	Shipping Weight lbs (kg)
Long				
NW63-NW40	IKA063040L	1.50 in.	2.71 (68.8)	1.0 (0.5)
Short				
NW63-NW16	IKA063016S	0.75 in.	1.75 (44.5)	1.0 (0.5)
NW63-NW25	IKA063025S	1.00 in.	1.75 (44.5)	1.0 (0.5)
NW63-NW40	IKA063040S	1.50 in.	1.75 (44.5)	1.0 (0.5)
NW63-NW50	IKA063050S	2.00 in.	1.75 (44.5)	1.5 (0.7)
NW80-NW25	IKA080025S	1.00 in.	1.75 (44.5)	1.5 (0.7)
NW100-NW25	IKA100025S	1.00 in.	1.75 (44.5)	2.0 (0.9)
NW100-NW40	IKA100040S	1.50 in.	1.75 (44.5)	2.0 (0.9)
NW100-NW50	IKA100050S	2.00 in.	1.75 (44.5)	2.5 (1.1)
NW160-NW40	IKA160040S	1.50 in.	1.75 (44.5)	5.0 (2.3)
NW160-NW50	IKA160050S	2.00 in.	1.75 (44.5)	6.0 (2.7)

FEEDTHROUGHS

▶ Rotary Motion Feedthrough

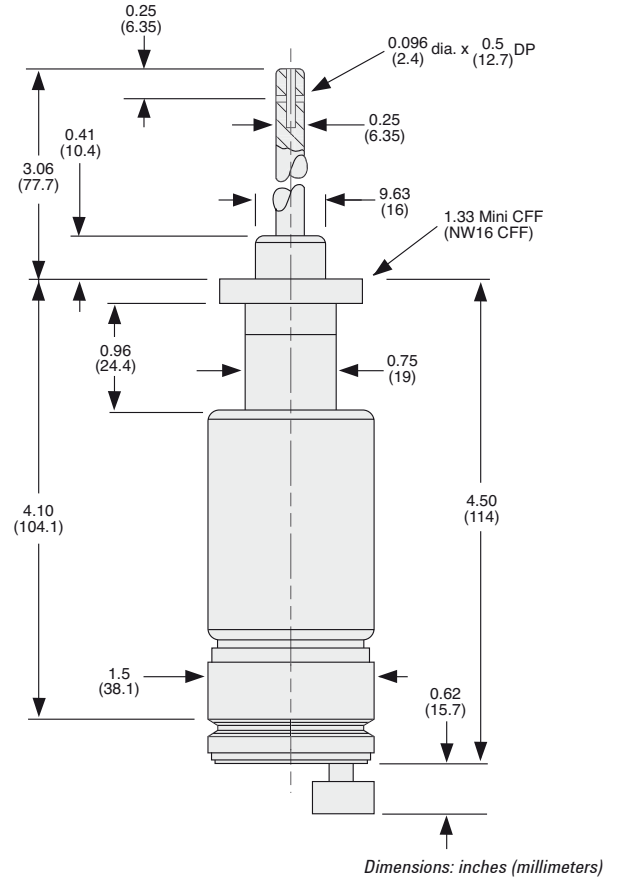

Especially well-suited for bakeable ultra-high vacuum applications, this rotary motion feedthrough is bellows-sealed and has a built-in lock. It is mounted on a 1.33 in. OD Mini-ConFlat flange (NW16 CFF).

Technical Specifications

Vacuum Range	Atmosphere to 10^{-11} Torr (mbar)
Torque Rating	150 inch-ounces
Speed	200 RPM maximum
Runout at Shaft Tip	0.006" maximum (0.15 mm)
Life	50,000 total turns nominal 300 °C maximum (bakeout)
Temperature	-196 °C to +150 °C (operating)
Rotation	Continuously rotatable in either direction

Ordering Information

Description	Part Number	Shipping Weight lbs (kg)
Rotary motion feedthrough		
On 1 1/2 in. mini ConFlat flange (NW16 CFF)	L6691301	5.0 (2.3)
Gaskets for mini ConFlat flange (NW16 CFF), 10/pkg	FG0133CI	1.0 (0.5)

VACUUM COMPONENTS

▶ 12 kV Fischer Feedthrough on Mini-ConFlat Flange

This high voltage feedthrough is rated at up to 12 kV (below 10^{-4} Torr/mbar) and is provided with a Mini (1.33 in.) ConFlat flange (NW16 CFF).

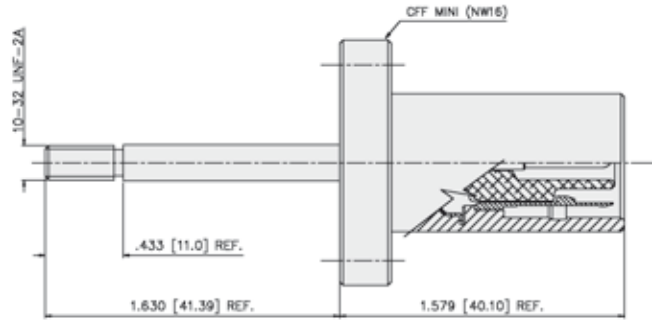

Dimensions: inches (millimeters)

Technical Specifications

Voltage Rating (below 10^{-4} Torr/mbar)	12 kV F/T Fischer
Current Rating	1A maximum
Temperature Range	-196 °C to +450 °C
Body Material	Stainless Steel
Mounting Flange	1.33 in. O.D. mini (NW 16)

Ordering Information

Description	Part Number	Shipping Weight lbs (kg)
High voltage feedthrough, vacuum side mating connector. With 1 1/2 in. Mini-ConFlat flange (NW16 CFF) (for Star-Cell Ion pumps, cables and connectors please see the Ion Pumps section) (external connector not included, please order separately)	9595125	1.0 (0.5)
Gaskets for Mini-ConFlat flange (NW16 CFF) 10/pkg	FG0133CI	1.0 (0.5)

SUPPLIES, GREASES AND LUBRICANTS

▶ Torr Seal Low Vapor Pressure Resin Sealant



Torr Seal epoxy resin quickly seals leaks on any type of vacuum system or component. Provided in convenient tubes, Torr Seal is solvent-free and can be used at pressures of 10^{-9} Torr (mbar) and below, at temperatures from -45°C to 120°C (bakeable temperature). Additionally, Torr Seal permits leak checking immediately after curing and bonds with many materials including metal, ceramic, and glass.

Ordering Information

Description	Part Number	Weight lbs (kg)
Torr Seal base resin, 82 grams, and Torr Seal hardener, 36 grams	9530001	1.0 (0.45)

▶ Torr Seal Mixing System

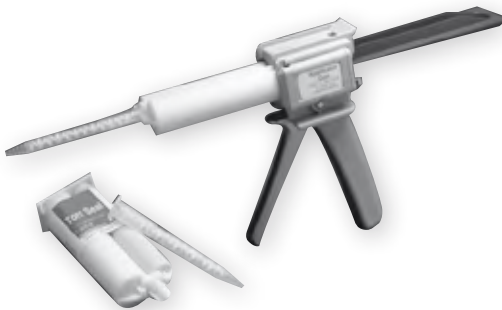

The Torr Seal Mixing System includes an applicator gun, a premeasured Torr Seal cartridge, and an epoxy/resin mixer. The system uses the same low vapor pressure resin sealant as standard Torr Seal, while providing a systematic and scientific way of mixing the Torr Seal epoxy and resin. The applicator gun dispenses premeasured epoxy and resin from the cartridge through the mixer so that a uniform Torr Seal bead can be placed on any surface. As with the standard Torr Seal tubes, the mixing system can be used at pressures of 10^{-9} Torr and below, and at temperatures from -45°C to 120°C (bakeable temperature).

Ordering Information

Description	Part Number	Weight lbs (kg)
Applicator gun with Torr Seal cartridge (2 oz.) and three mixers	9530002	2.00 (0.91)
Applicator gun only	9530003	1.50 (0.68)
Torr Seal cartridge (2 oz.) and three mixers	9530004	0.75 (0.34)
Mixers only (six to a package)	9530005	0.25 (0.11)

▶ Fel-Pro Heavy Duty Anti-Seize

Fel-Pro Heavy Duty Anti-Seize is a high-temperature, anti-galling lubricant designed for screw threads and other mated components of all types. Generally used in applications that are external to vacuum systems, Fel-Pro is useful in temperature ranges of 70°C to $+1315^{\circ}\text{C}$.

Ordering Information

Description	Part Number	Weight lbs (kg)
Fel-Pro Heavy Duty Anti-Seize Lubricant	9530031	0.3 (0.13)

▶ Apiezon Vacuum Grease, Type L

Apiezon L is a general vacuum grease that has a vapor pressure from 10^{-11} Torr (mbar) at 20°C to 10^{-3} Torr (mbar) at 300°C , and has a melting point of $< 50^{\circ}\text{C}$.

Ordering Information

Description	Part Number	Weight lbs (kg)
Apiezon L vacuum grease, 1 oz.	695400004	1.0 (0.45)

▶ Agilent Vacuum Grease

This is a general purpose grease with a vapor pressure in the 10^{-6} Torr range. It is a non-silicone grease that comes in two viscosities and two sizes.

Ordering Information

Description	Part Number	Weight lbs (kg)
Agilent Vacuum grease, Medium Weight, $\frac{1}{4}$ lb size	LGCMID025	1.0 (0.45)
Agilent Vacuum grease, Medium Weight, 1 lb size	LGCMID100	1.0 (0.45)
Agilent Vacuum grease, Heavy Weight, $\frac{1}{4}$ lb size	LGCHEV025	1.0 (0.45)
Agilent Vacuum grease, Heavy Weight, 1 lb size	LGCHEV100	1.0 (0.45)



AGILENT TRAINING

- 2-3 Features and Benefits
- 4-7 Vacuum and Leak Detection
- 8 Equipment Maintenance
- 9 Primary Pump Rebuilding
- 9 Custom On-Site Training
- 10-18 Formulas and Tables
- 19-27 Glossary



Agilent Technologies

FEATURES AND BENEFITS

Since our invention of the Vaclon ultra-high vacuum pump over 40 years ago, Varian, now Agilent, has maintained a leadership position in vacuum and leak detection technology for industrial and scientific applications. Agilent's highly-regarded training program is staffed by dedicated professional trainers with the expertise and experience to provide comprehensive and thorough instruction on a broad range of vacuum and leak detection technologies. Limited enrollment ensures attendees have ample opportunity to interact with instructors, and to participate in demonstration activities during courses utilizing Agilent's fully-equipped labs.

Courses are offered at Agilent training facilities in Santa Clara, CA and Lexington, MA (USA), at regional locations throughout North America, and at Agilent training facilities in Europe, and at customer locations world-wide.

Agilent's Training Department develops cost-effective customized vacuum and leak detection training programs tailored to meet specific training requirements for course content and duration. Agilent's professional trainers deliver custom training programs at customer locations world-wide through our Custom On-Site Training program.

Please visit our website at
www.agilent.com/chem/vacuum

Open the Training & Events tab,
Select "Training Courses"

In the Product Line box at left, select "Vacuum Technologies".

for training dates, locations, prices and registration forms, or contact Agilent toll free in the United States at 1 (800) 882 7426, or Toll Free in Europe at 00 (800) 234 234 00.



Trainer's Expertise

Agilent's dedicated training professionals bring years of experience in a wide range of vacuum and leak detection applications to the classroom.



Course Offering

Agilent offers a broad range of Vacuum, Leak Detection and Equipment Operation & Maintenance courses to suit every customer's need, with regularly scheduled courses, or through our On-Site Training programs.

TRAINING

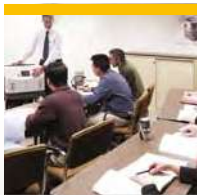

Small Class Sizes

Limited course enrollment enhances student-trainer interaction and promotes participation by students.



Vacuum Demo Labs

Fully equipped laboratory facilities provide access to a variety of vacuum pumps, gauges and components.



Methodology

A combination of theory and hands-on activities are used to facilitate and reinforce the learning process.



Local languages

Courses held in Europe are taught in English, French, German and Italian, using training materials in the native language, and taught by instructors fluent in the native language.



Locations

Regularly scheduled courses are held at Agilent locations in the US and Europe. On-Site courses are also available for customers' convenience.

AGILENT VACUUM AND LEAK DETECTION

Basic Vacuum Practice (BVP)

3 Days

Course Description

This course provides practical information on vacuum system operation, performance, and maintenance, as well as a comprehensive treatment of vacuum technology. In addition, the process of using a Helium Mass Spectrometer Leak Detector (HMSLD) to locate vacuum system leaks is thoroughly covered. Gain the practical knowledge to properly characterize, operate, and maintain your vacuum system for maximum uptime. Lab equipment, including a turbo-pumped high vacuum system and an HMSLD, is provided for instructor-led demonstrations. Participants will receive the Basic Vacuum Practice Workbook, an excellent source of practical information.

Basic Vacuum Practice is the required prerequisite for Leak Rate Test and Measurement (LRTM-BC) and Advanced Vacuum Practice (AVP).

Who Should Attend?

Technicians, engineers, and scientists who use vacuum technology in their work environment and who need to acquire a detailed understanding of the underlying principles, as well as become proficient at operating and maintaining vacuum systems.

Course Goals and Objectives

After completing this course, participants will be able to:

- Describe gas properties and laws
- Properly pump-down and cycle vacuum systems
- Identify advantages and disadvantages of available pumping methods
- Select appropriate gauging and materials at different vacuum levels
- Describe routine maintenance requirements for pumps and components
- Characterize vacuum system performance
- Describe HMSLD principles of operation
- Properly operate, tune, and calibrate a HMSLD
- Troubleshoot and locate vacuum system leaks

Course Outline

Day 1

Introduction to Vacuum Applications and Fundamentals

- Working with numbers and temperature scales
- Understanding matter, pressure, gas properties
- Vapor pressure and outgassing
- Gas flow and conductance
- Pumping speed and throughput
- Overview of vacuum pumping methods
- Rough Vacuum Systems
 - Gauges
 - Wet and dry mechanical pumps
 - Traps and filters
 - Sorption (entrapment) pump
 - Pump comparison
 - *Demo Lab:* Rough vacuum system operation

Day 2

High & Ultra High Vacuum Systems

- High Vacuum
 - Gauges
 - Turbo pumps/controllers and diffusion pumps
 - Baffles and traps
 - Cryopumps
 - Pump comparison
 - System configurations and operation
 - *Demo Lab:* High vacuum system assembly and operation
- Ultra High Vacuum
 - Outgassing issues
 - Gauges
 - Ion pumps
 - Non-evaporative getter pumps
 - Titanium sublimation pumps
 - System configurations and operation

Day 3

Vacuum Materials and Hardware

- Material selections
- Joining techniques
- Fittings, feedthroughs, and valves
- Vacuum system performance and troubleshooting
- Characterizing the system
- Problems and sources
- Methods, techniques, and tools
- Helium Leak Detector
 - Principles of operation
 - Tuning and calibration procedures
 - Vacuum system leak-checking techniques
 - *Demo Lab:* System performance troubleshooting and leak detection

Course Description

Basic Vacuum Practice is the required prerequisite and scheduled to immediately precede LRTM-BC. This course is a “companion” to the BVP course: building on the vacuum and Helium Mass Spectrometer Leak Detector (HMSLD) fundamentals learned in BVP, it provides an introduction to production testing of parts against leak-rate specifications, and measuring and locating leaks in pressurized systems/components, using an HMSLD. Leak testing methods designed to solve various problems are discussed and demonstrated.

Excellent for product/manufacturing engineers and equipment operators, this intensive program addresses the advantages and limitations of various leak-testing techniques and explores ways to get the best performance from an HMSLD. Lab equipment, including popular helium mass spectrometer leak detectors and various application test fixtures, is provided for instructor-led demonstrations.

Who Should Attend?

Engineers and operators who are responsible for quality control of production parts and assemblies. Also, technicians responsible for the maintenance of pressurized and evacuated systems such as those found in power generation facilities, process gas delivery, and refrigeration, etc.

Course Goals and Objectives

After completing this course, participants will be able to:

- Identify advantages and disadvantages of various leak testing methods
- Describe leak rate specifications and helium conversions.
- Select, setup, and perform the proper leak test technique for a given application

Course Outline

Introduction to Leak Detection

- Why leak test?
- Leak detection operations
- Understanding leak rate
- Leak detection methods

Leak Rate Specification Conversions

- Specification leak rate vs. std cc/sec
- Specification pressure vs. test pressure
- The helium leak rate

Locating Leaks

- Spray and sniffer probe techniques
- *Demo Lab*: Find leaks in evacuated and pressurized parts

Measuring Leak Rate

- Leak rate testing software overview
- Hard vacuum: Inside-out testing (pressurized part)
- Hard vacuum: Outside-in testing (evacuated part)
- Bombing
- Accumulation testing
- *Demo Lab*: Measure leak rates

Application Specific Leak Rate Testing Examples

- Hermetically sealed parts
- Pressurized parts: accumulation method (joints/welds/crimps, AC lines, brake lines, valves)
- Pre-pressurized parts in large vacuum chamber (compressor, heater core, wheel, gas tank, transmission, torque converter)
- Parts with pressure differential intolerance (gas tanks, gas caps, filler necks)
- Small part/high sensitivity
- Long narrow tubes
- Process gas components and systems



AGILENT VACUUM AND LEAK DETECTION

Leak Rate Test and Measurement: Stand-Alone (LRTM-SA)

2 Days

Course Description

This “Stand-Alone” course provides an all inclusive introduction to production testing of parts against leak rate specifications, and measuring and locating leaks in pressurized systems and components, using a Helium Mass Spectrometer Leak Detector (HMSLD). Principles of operation of the spectrometer and underlying vacuum fundamentals are presented in a classroom setting. Operation, tuning, and calibration of the leak detector are covered in practical demonstration/laboratory sessions. Leak testing methods designed to solve various problems are discussed and demonstrated.

Excellent for product/manufacturing engineers and equipment operators, this intensive program addresses the advantages and limitations of various leak-testing techniques and explores ways to get the best performance from an HMSLD. Lab equipment, including popular helium mass spectrometer leak detectors and various application test fixtures, is provided for instructor-led demonstrations.

Who Should Attend?

Engineers and operators who are responsible for quality control of production parts and assemblies. Also, technicians responsible for the maintenance of pressurized and evacuated systems such as those found in power generation facilities, process gas delivery, and refrigeration, etc.

Course Goals and Objectives

After completing this course, participants will be able to:

- Describe gas properties and laws
- Identify advantages and disadvantages of various leak testing methods
- Explain vacuum fundamentals and concepts essential to the operation of an HMSLD
- Describe principles of operation of a mass spectrometer
- Properly operate, tune, and calibrate an HMSLD
- Describe rate-leak specifications and helium conversions
- Select, setup, and perform the proper leak test technique for a given application

Course Outline

Day 1

Introduction to Leak Detection

- Why leak test?
- Leak detection operations
- Understanding leak rate
- Leak detection methods

Vacuum Fundamentals for Leak Detection:

- Working with numbers and temperature scales
- Understanding matter, pressure, gas properties
- Vapor pressure, outgassing, gas flow, conductance.
- Pumping speed and throughput

Introduction to Rough Vacuum Systems

- Operating pressure range and gauging
- Wet and dry pump operations
- System operation
- *Demo Lab:* Roughing pumpdown

Introduction to High Vacuum Systems

- Operating pressure range and gauging
- Turbo pump and system operation

Helium Leak Detector Fundamentals

- System components
- Vacuum system architecture
- Spectrometer: operation, tuning, zeroing, calibration
- *Demo Lab:* Tuning, zeroing, and calibration

Day 2

HMSLD performance considerations

- Response/appearance time
- Cleanup time (disappearance)

Leak-Rate Specification Conversions

- Specification leak rate vs. standard cc/second
- Specification pressure vs. test pressure
- The helium leak rate locating leaks
- Spray and sniffer probe techniques
- *Demo Lab:* Find leaks in evacuated and pressurized parts

Measuring Leak Rate

- Leak-rate testing software overview
- Hard vacuum: Inside-out testing (pressurized part)
- Hard vacuum: Outside-in testing (evacuated part)
- Bombing
- Accumulation testing
- *Demo Lab:* Measure leak rates

Application-Specific Leak-Rate Testing examples

- Hermetically sealed parts
- Pressurized parts: accumulation method (joints/welds/ crimps, AC lines, brake lines, valves)
- Pre-pressurized parts in large vacuum chamber (compressor, heater core, wheel, gas tank, transmission, torque converter)
- Parts with pressure-differential intolerance (gas tanks, gas caps, filler necks)
- Small part/high sensitivity
- Long narrow tubes
- Process gas components and systems

Advanced Vacuum Practice (AVP)

3 Days

Course Description

Basic Vacuum Practice is the required prerequisite. Building on Basic Vacuum Practice (BVP), this course begins with a short review of vacuum theory and moves on to calculations for building and characterizing a vacuum system designed to perform at specified pressures. Participants use lab facilities to build and test vacuum system designs. Knowledge gained from this class will be extremely valuable for vacuum applications in the semiconductor, R&D, and manufacturing sectors.

Who Should Attend?

Lab technicians, engineers, university students, professors, and research scientists who use vacuum technology in their work environment and who need to specify and configure vacuum systems that meet various application performance requirements.

Course Goals and Objectives

After completing this course, participants will be able to:

- Evaluate vacuum system performance
- Comprehensively describe effects of outgassing, permeation, and leaks
- Select proper materials to minimize gas load
- Perform calculations to estimate gas load, pumping speed, and pumpdown time
- Calculate conductance values
- Select appropriate pumps and gauging
- Design, build, and evaluate an elementary vacuum system

Course Outline

Day 1

Gas and Surface Physics

- Macroscopic properties
- Microscopic properties
- Surface effects
- Vapor Pressure review vacuum technology
- Gas flow
- Speed calculations
- Chamber pumpdown
- Working with $Q=SP$

Rough Vacuum

- Vacuum system design criteria
- Rough vacuum pump and gauge selection
 - Criteria, pumps, specifications, comparisons
 - Pumpdown calculations
 - Load lock dilution pressure
- *Hands-On Lab*: Calculate roughing system pumpdown; assemble and measure

Day 2

Conductance Calculations

- End effects
- Formulas and their usage
- Effective pumping speed
- System case study
- *Hands-On Lab*: Calculate and measure effect of conductance on pump-down gas load analysis
- Outgassing rates and calculations
- Permeation and leak effects

Materials Selection

- Characteristics
- Fabrication techniques

Day 3

High and Ultra-High vacuum

- Characteristics
- Example systems
- HV/UHV pump and gauge selection
- Criteria, pumps, specifications, comparisons
- Systems sizing calculations
- Diffusion pump, turbo, and cryopump
- Backing requirements
- *Hands-On Lab*: Calculate and measure pumping speed, throughput, and outgassing

Vacuum System Performance and Troubleshooting Theory and Application of RGA

- Principles of operation
- Fragmentation patterns
- System interconnections
- *Hands-On Lab*: Analyze existing systems

Course Description

This course provides participants with the ability to perform routine maintenance and troubleshooting procedures on supported Agilent leak detectors. Training is normally held at the customer site and covers Agilent VS, 959, 979, and other Leak Detector models.

LDM begins with an introduction to leak detection and vacuum fundamentals then covers the principles of spectrometer operation and the underlying vacuum system in a classroom setting. Leak detector operation, tuning, and calibration, as well as preventative maintenance and troubleshooting procedures, are covered in practical laboratory sessions.

Lab equipment, including Agilent leak detectors and various maintenance consumables, is provided for extensive hands-on lab activities and instructor-led demonstrations. Participants will work with the Agilent leak detector model that they use in their work environment.

Who Should Attend?

This course is for maintenance technicians and personnel responsible for maintaining Agilent leak detectors.

Course Goals and Objectives

After completing this course, participants will be able to:

- Explain vacuum fundamentals and concepts essential to the operation of a leak detector
- Describe principles of operation of a helium mass spectrometer and ContraFlow
- Identify all major leak detector components
- Properly operate, tune, and calibrate the leak detector
- Perform preventative maintenance procedures:
 - Spectrometer cleaning and seal replacement
 - Ion source replacement
 - Valve blocks and manifold cleaning
 - Mechanical and high vacuum pumps
- Troubleshoot routine problems

Course Outline

Day 1

Introduction to Leak Detection

- Why leak test?
- Leak detection basics

Overview of Vacuum for Leak Detectors

- Working with numbers
- Understanding matter, pressure, gas properties
- Vapor pressure and gas flow
- Pumping speed and throughput

Introduction to Rough Vacuum Systems

- Operating pressure range and gauging
- Wet and dry pump operations
- Maintenance issues
- System configuration and operation
- *Hands-On Lab:* Roughing pump-down

Introduction to High Vacuum Systems

- Operating pressure range and gauging
- Turbo pump and controller operation
- Diffusion pump operation
 - Baffles and traps
 - Maintenance issues
- System configuration and operation

Leak Detector Fundamentals

- System components
- Vacuum system architecture
- Contra-flow concepts
- Mass spectrometer principles of operation
- Operating sequence
- *Hands-On Lab:* ID system components

Day 2

Operation of the Leak Detector

- Front panel displays and controls
- Operator interface
- *Hands-On Lab:* Operating the leak detector
- **Spectrometer Tuning, Zeroing, and Calibration**
- Tuning leak
- Background helium signal
- Calibrated leak
- *Hands-On Lab:* Manual tuning, zeroing, and calibration

Spectrometer Maintenance Procedures

- *Hands-On Lab:* Clean spectrometer and replace Ion source

System Electronics

- Block diagram overview
- Test Points and adjustments
- *Hands-On:* ID components and verify test point data

Gauge Maintenance

- Procedures
- *Hands-On Lab:* Calibrate test port and system gauge

Day 3

Valve Block and Manifold Maintenance Procedures

- *Hands-On Lab:* Clean valve block and manifold

Mechanical Pump Maintenance Procedures

- *Hands-On Lab:* RV/TS pump maintenance

High Vacuum Pump Maintenance Procedures

- *Hands-On Lab:* DP/TP pump maintenance

System Troubleshooting

- Symptom: Cause overview
- Procedures
- *Hands-On Lab:* Troubleshoot common problems

Mechanical Pump Rebuilding

1 Day

TriScroll Dry Scroll Pump

Course Description

Agilent offers customers the opportunity to service and rebuild Agilent TriScroll dry vacuum pumps. This one-day course, available through Agilent's On-Site program, covers required minor and major service for TriScroll 300 and TriScroll 600 scroll pumps.

Class size is limited to 8 attendees



DS Series Oil-Seal Rotary Vane Pump

Course Description

Agilent offers customers the opportunity to service and rebuild Agilent DS Series oil-sealed rotary vane vacuum pumps. This one-day course, available through Agilent's On-Site program, covers a comprehensive tear down and rebuild of the pump.

Class size is limited to 8 attendees



On-Site Training Programs

Agilent's Training Department can assist customers in meeting their specific training requirements by organizing and sequencing customer-selected content topics from Agilent's standard vacuum practice curriculum. Our professional instructors will deliver this cost-effective training at your facility through our On-Site Training Program. Please contact the Training Department at 800.882.7426 (x5489) for assistance.

On-Site Training Advantages:

- Professional vacuum and leak detection training provided at your facility
- Tailored content from our Standard Courses
- Scheduled when you need the training
- Eliminates employee travel time and expenses
- Cost effective for training groups of employees

Training Registration:

An online registration form can be found on the Agilent training web site:

www.agilent.com/chem/vacuum

Open the Training & Events tab,

Select "Training Courses"

In the Product Line box at left, select "Vacuum Technologies".

APPENDIX - FORMULAS AND TABLES

Common Physics Values

Acceleration gravity	$g = 9.806 \text{ m sec}^2$ (32.174 Ft sec ²)
Atomic Mass Unit AMU	$= 1.6605 \times 10^{-24}$ grams
Angstrom unit	$\text{Å} = 10^{-10} \text{ m} = 0.1 \text{ nm}$
Avogadro's number	$n = 6,0221353 \times 10^{23} \text{ mol}^{-1}$ (number of particles per mol)
Molar volume	$= 22.41$ liters (at 1 atm and 273 °K)
Boltzmann's constant	$k = 1.38 \times 10^{-16}$ ergs deg ⁻¹ molecule ⁻¹
Plank's constant	$h = 6.6256 \times 10^{-34}$ J sec
Electron charge	$q = 1.602 \times 10^{-19}$ coulomb
Equivalent of heat	$J = 4.185 \times 10^3$ Joules K cal ⁻¹
Natural log base	$e = 2.7183$
Velocity of light	$c = 2.9979 \times 10^8$ m sec ⁻¹
Velocity of sound	$s = 330$ m sec ⁻¹
Standard pressure	$p = 101.325 \text{ Pa} = 1013 \text{ mbar}$ (at 45°north and 0 °C)
Magnetic flux density	$T = \text{Tesla. (1 gauss } G = 10^{-4} \text{ Vs m}^{-2} = 10^{-4} \text{ T)}$

Ideal Gas Equation

PV = nRT	or	PV = nkT
P = pressure in Torr		P = pressure in dynes
V = volume in liters		V = volume in cc
n = numbers of Moles		n = numbers of Moles
R0 = molar gas constant		k = Boltzmann's constant
T = degrees Kelvin		T = degrees Kelvin

p	V	T	R0
Newton /m ²	m ³	°K	8.314 Joule / °K g mole
dyne / cm ²	cm ³	°K	8.314×10^{-7} erg / °K g mole
Torr	cm ³	°K	6.236×10^4 Torr cm ³ / °K g mole
Torr	liters	°K	62.364 Torr liters / °K g mole
atm	cm ³	°K	82.057 atm cm ³ / °K g mole

Physical Properties of some Gases

Gas	Chemical formula	Molecular weight
Hydrogen	H ₂	2.016
Helium	He	4.002
Deuterium	D ₂	4.028
Methane	CH ₄	16.04
Ammonia	NH ₃	17.03
Water (vapour)	H ₂ O	18.02
Neon	Ne	20.18
Nitrogen	N ₂	28.01
Oxygen	O ₂	31.99
Argon	Ar	39.94
Carbon dioxide	CO ₂	44.01
Krypton	Kr	83.80
Xeno	Xe	131.30
Mercury	Hg	200.59

Temperature Scale

Conversion Table			
°F	°C	°K	
212	100	373	Boiling point of water
32	0	273	Freezing point of water
-321	-196	77	Boiling point of LN ₂
-459	-273	0	Absolute zero

Conversion factors:		
°C = 5/9 (F - 32)	°K = C + 273	°F = 9/5 C + 32
°C = Celsius	°K = Kelvin	°F = Fahrenheit

Some Molecular Relationships (at 273 °K)

Pressure Torr	Molecular density molec./cm ³	Molecular collision molec./cm ² x sec	Mean free path cm	Monolayer formation time (sec)
760	3.25 x 10 ¹⁹	3.78 x 10 ²³	5.1 x 10 ⁻⁶	2.2 x 10 ⁻⁹
10 ⁻³	3.25 x 10 ¹³	3.78 x 10 ¹⁷	5.1	2.2 x 10 ⁻³
10 ⁻⁶	3.25 x 10 ¹⁰	3.78 x 10 ¹⁴	5100	2.2
10 ⁻⁹	3.25 x 10 ⁷	3.78 x 10 ¹¹	5.1 x 10 ⁶	2200
10 ⁻¹²	3.25 x 10 ⁴	3.78 x 10 ⁸	5.1 x 10 ⁹	2.2 x 10 ⁶

Common Physics Values

Pressure Conversion Table

	Torr	mbar	Pa	micron	psi	atm
1 Torr	1	1.33	133	1000	1.9 x 10 ⁻²	1.32 x 10 ⁻³
1 mbar	0.751	1	100	750	1.4 x 10 ⁻²	9 x 10 ⁻⁴
1 Pa	7.51 x 10 ⁻³	1 x 10 ⁻²	1	7.5	1.4 x 10 ⁻⁴	9 x 10 ⁻⁶
1 micron (mTorr)	1 x 10 ⁻³	1.3 x 10 ⁻³	1.3 x 10 ⁻¹	1	1.9 x 10 ⁻⁵	1.3 x 10 ⁻⁶
1 psi (a)	51.72	68.96	6.89 x 10 ³	5.17 x 10 ⁴	1	7 x 10 ⁻²
1 atm	760	1013	1.01 x 10 ⁵	7.6 x 10 ⁵	14.7	1

Pressure on vacuum technology are always considered absolute pressure.

Gas Flow Characteristics

Viscous Flow Distance between molecules is small; collisions between molecules dominate; flow is through momentum transfer; generally P greater than 1 millibar.

$$\bar{p} \times D > 0.7 \text{ (mbar cm); } \lambda < D/100$$

$$\text{Pressure (millibar) x Diameter (centimeters) = } > 0.7$$

Transition Flow Region between viscous and molecular flow

$$1.3 \times 10^{-2} < \bar{p} \times D < 0.7 \text{ (mbar cm); } D/100 < \lambda < D/2$$

Molecular Flow Distance between molecules is large; collisions between molecules and wall dominate; flow is through random motion; generally P is smaller than 10⁻³ millibar. A system is in molecular flow when the mean free path is longer than the diameter of the tube or chamber.

$$\bar{p} \times D < 1.3 \times 10^{-2} \text{ (mbar cm); } \lambda < D/2$$

$$\text{Pressure (millibar) x Diameter (centimeters) = } < 0.013$$

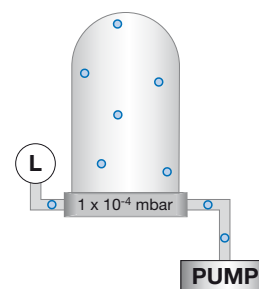
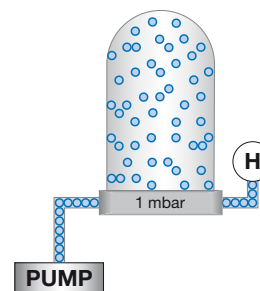

APPENDIX - FORMULAS AND TABLES

Conductance - Viscous Flow Formulas

Conductance changes according to the pressure in the pipe.
For air at 20 °C:

Aperture	$C = 20 A$	where $A = \text{Area, cm}^2$ $C = \text{l/sec}$
Pipe	$C = \frac{137 D^4}{L} \bar{p}$	$D = \text{Diameter, cm}$ $P = \text{Pressure, mbar}$ $L = \text{Length, cm}$

Conductance - Molecular Flow Formulas

The conductance is independent of the pressure.
For air at 20 °C:

Aperture	$C = 11.6 A$	where $A = \text{Area, cm}^2$ $C = \text{l/sec}$
Long pipe	$C = \frac{12.1 D^3}{L}$	$D = \text{Diameter, cm}$ $L = \text{Length, cm}$ valid when Length >> Diameter
Short pipe	$C = \frac{11.6 A}{1 + L/D}$	$D = \text{Diameter, cm}$ $L = \text{Length, cm}$ valid when Length < 0.7 times Diameter

Series Conductance and Effective Pumping Speed

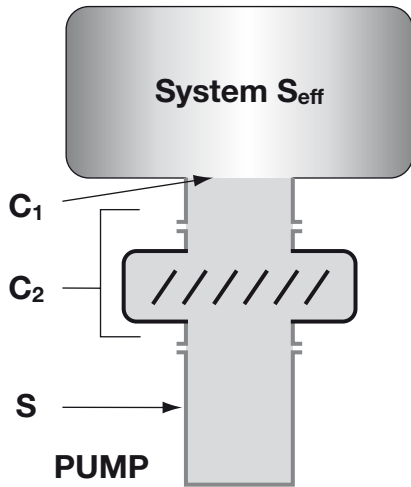

$$\frac{1}{C_T} = \frac{1}{C_1} + \frac{1}{C_2}$$

$$C_T = \frac{C_1 \times C_2}{C_1 + C_2}$$

$$\frac{1}{S_{eff}} = \frac{1}{S} + \frac{1}{C_T}$$

$$S_{eff} = \frac{S \times C_T}{S + C_T}$$

where S_{eff} = Effective pumping speed (l/s)
 S = Nominal pumping speed (l/s)
 C = Conductance (l/s)

Pumping Speed - Conversion Table

		l/s	l/min	m³/h	CFM
1 liter per second	=	1	60	3.6	2.19
1 liter per minute	=	0.01666	1	0.06	0.0353
1 cubic meter per hour	=	0.287	16.67	1	0.589
1 cubic feet per minute	=	0.472	28.32	1.70	1

Pump Down Calculation (Viscous Flow)

This equation is accurate from start to approximately 1 mbar.
At lower pressures outgassing can become significant.

$$t = \frac{V}{S} \ln \frac{P_o}{P_f}$$

t = pump down time (sec) multiply by:
 S = pumping speed (l/sec) 1.5 for pressure to 0.5 mbar
 V = Chamber Volume (l) 2 to 5×10^{-2} mbar
 P_o = beginning pressure mbar 4 to 1×10^{-3} mbar
 P_f = Final pressure ($\ln = 2.3 \log_{10}$)

Throughput

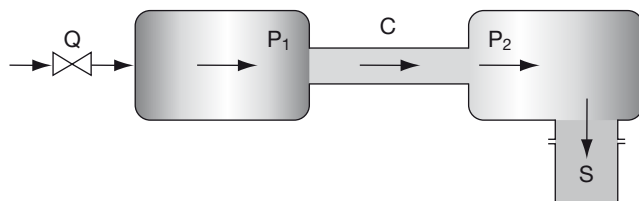

Throughput: quantity of gas per unit time,

$$Q = C \times (P_1 - P_2) = P_2 \times S \quad \text{or:} \quad Q = \frac{V}{t} P = SP$$

Throughput = Conductance x Pressure = Pressure x Pump Speed

Throughput is expressed in mbar liters/sec, Torr liters/sec, standard cc's/min.

Unit of Throughput - Flow - Leak Rate - Conversion Table

	STD cc/sec atm cc/sec mbar l/sec	molecules/s (a 0°C)	Torr l/sec	Pa m ³ /sec	sccm
1 STD cc/sec – 1 atm cc/sec – 1 mbar l/sec	1	2.687×10^{19}	0.76	0.1	60
1 molecule/s	3.72×10^{-20}	1	2.86×10^{-20}	3.72×10^{-21}	2.23×10^{-18}
1 Torr l/sec	1.3	3.493×10^{19}	1	0.13	80
1 Pa m ³ /sec	10	2.687×10^{20}	7.5	1	600
1 sccm	0.016	4.299×10^{17}	0.0125	0.016	1

Pump Down Calculation (Molecular Flow)

Where gas load is dependent upon outgassing, the final pressure depends on the property of the surface and time necessary to reach the working pressure may be calculated by the following relation:

$$t = \frac{Q_{\text{outgas}} \times A \times t_0}{S_{\text{eff}} \times P_{\text{work}}}$$

Where

- t = time (hours) necessary to reach the working pressure
- Q_{outgas} = gas load referred to time t_0 (generally 1 hour)
- A = internal area exposed to vacuum
- P_{work} = working pressure
- S_{eff} = effective pumping speed

Outgassing Rate per Unit Area

Outgas	Torr liter sec cm ²	1h	10h	100h
Viton A – Dry		2×10^{-6}	1×10^{-7}	1×10^{-9}
Aluminum – Cleaned		1×10^{-8}	1×10^{-9}	2×10^{-10}
Stainless – Degreased		2×10^{-9}	2×10^{-10}	2×10^{-11}
Stainless – Cleaned		3×10^{-9}	1.5×10^{-10}	2×10^{-11}
Stainless – 24 h baked at 150 °C		4×10^{-12}	4×10^{-12}	4×10^{-12}

Ultimate Pressure

The ultimate pressure of the vacuum system is determined by the pumping speed and the limiting compression for various gases

$$P_1 = \left(\sum \frac{Q_i}{S_i} \right)_{\text{ext}} + \left(\sum \frac{Q_i}{S_i} \right)_{\text{int}} + \sum \frac{P_{2i}}{K_i}$$

Where Q_i is the gas load from a gas type i and S_i is the pumping speed for that gas. P_{2i} is the outlet pressure for gas type i and K_i is the compression ratio of the pump for gas type i .

APPENDIX - FORMULAS AND TABLES

Vacuum Technology Standards

Number	Title
DIN 28400	Vacuum technology; designations and definitions
DIN 28401	Graphic Symbols in Vacuum Technology
DIN 28402	Vacuum technology; variables, symbols, units - overview
DIN 28403 ISO 1609 PNEURO P 6606	Vacuum technology; quick connections, small flange connections
DIN 28404 ISO 1609 PNEURO P 6606	Vacuum technology; flanges, dimensions
DIN 28410	Vacuum technology; mass spectrometer partial pressure gauges, definitions
DIN 28411 ISO 3530.2	Mass Spectrometer type Leak Detector Calibration
DIN 28416	Calibration of Vacuum Gauges – General method
DIN 28417	Measurement of Throughput by volumetric method
DIN 28418 ISO/DIS 3567	Vacuum Gauges – Calibration by direct comparison
DIN 28426, part I, II ISO 1607 / 1,2 PNEURO P 6602	Positive Displacement Vacuum pumps- Measurement of performance characteristics. Measurement of ultimate pressure
DIN 28427 ISO 1608 / 1,2 PNEURO P 5607	Vapor Vacuum Pumps - Measurement of performance characteristics. Measurement of critical backing pressure
DIN 28428 PNEURO P 5608	Vacuum technology; acceptance specifications for Turbo Molecular Pumps
DIN 28429 PNEURO P 5615	Vacuum technology; acceptance specifications for Getter Pumps
DIN 28430 PNEURO P 6601	Measurement of performance of ejector vacuum pumps and ejector compressors
ISO 1314	Pressure; basic definitions, units
ISO 3529 I,II,III	Vacuum Technology Vocabulary
ISO/DIS 3556 / 1	Sputter Ion Pumps - Measurement of performance characteristics.
ISO/DIS 3568	Ionization Vacuum Gauges – Calibration by direct comparison
ISO/DIS 3570 / 1	Vacuum Gauges – Standard Methods for Calibration
ISO/DIS 3669	Bakeable Flange Dimensions
PN5ASR CC/5	Vacuum pumps, acceptance specifications refrigerator cooled cryopumps























ISO - International Standardization Organization – Switzerland

DIN - Deutsches Institut für Normung - Germany

PNEURO P – British compressed air society - England









Graphic Symbols in Vacuum Technology DIN28401

Vacuum Pumps

	Vacuum pump, general		Radial flow pump
	Positive displacement pump		Axial flow pump
	Positive displacement pump, oscillating		Gas ring vacuum pump
	Piston vacuum pump		Turbomolecular pump
	Diaphragm vacuum pump		Ejector vacuum pump
	Rotary positive displacement pump		Diffusion pump
	Rotary plunger vacuum pump		Adsorption pump
	Sliding vane rotary vacuum pump		Getter pump
	Rotary piston vacuum pump		Sublimation (evaporation) pump
	Liquid ring vacuum pump		Sputter ion pump
	Roots vacuum pump		Cryopump
	Turbine vacuum pump, general		

APPENDIX - FORMULAS AND TABLES









Vacuum Pump Accessories

	Condensate trap, general		Cooled baffle
	Condensate trap with heat exchange (e.g., cooled)		Cold trap, general
	Gas filter, general		Cold trap with coolant reservoir
	Filtering apparatus, general		Sorption trap
	Baffle, general		

Vacuum Chambers

	Vacuum chamber		Vacuum bell jar
---	----------------	---	-----------------

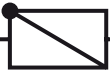
Isolation Devices

	Shut-off device, general		Right-angle stop cock
	Isolating valve		Gate valve
	Right angle valve		Butterfly valve
	Stop cock		Non-return valve
	Three-way stop cock		Safety shut-off device

Valve Mode of Operation



Manual operation



Hydraulic or pneumatic operation



Variable leak valve



Electric motor operation



Electromagnetic operation



Weight-operated

Connections and Tubes



Flange connection, general



Change in the cross section of a duct



Bolted flange connection



Intersection of two ducts with connection



Small flange connection



Crossover of two ducts without connection



Clamped flange connection



Electric current leadthrough



Threaded tube connection



Flexible connection (e.g., bellows, flexible tubing)



Ball-and-socket joint



Linear motion leadthrough, flange-mounted



Spigot-and-socket joint



Linear motion leadthrough, without flange



Connection by taper ground joint



Leadthrough for transmission of rotary and linear motion



Branch-off point



Rotary transmission leadthrough



Collection of ducts

APPENDIX - FORMULAS AND TABLES

Vacuum Gauges



General symbol for vacuum



Vacuum gauge control unit with dial indicator



Vacuum measurement, gauge head



Vacuum gauge control unit with digital indicator



Vacuum gauge, gauge control unit



Measurement of throughput



Vacuum gauge, control unit recording

<i>absolute pressure</i>	<i>See pressure, absolute.</i>
<i>absolute temperature</i>	The temperature scale that starts at “true” or absolute zero. It is often called the Kelvin scale.
<i>absorption</i>	The binding of a gas in the interior of a solid or liquid.
<i>adsorption</i>	The condensing of a gas on the surface of a solid.
<i>atmosphere, standard</i>	<i>See standard atmosphere.</i>
<i>atom</i>	The smallest identifiable part of an element. An atom has a nucleus with particles called protons and neutrons. Under normal conditions, it is surrounded by a number of electrons equal to the number of protons. Neutrons are neutral, protons are positively charged, and electrons are negatively charged.
<i>atomic mass unit</i>	A way of classifying atoms according to their weight, or mass. Atoms of the different elements have different weights, or masses.
<i>Avogadro’s Law</i>	The gas law that states that one mole of any gas has 6.023×10^{23} particles and under standard conditions occupies 22.4 liters.
<i>backing pump</i>	<i>See forepump.</i>
<i>backstreaming</i>	The small amount of pump fluid vapor that moves in the wrong direction, i.e., toward the work chamber.
<i>bakeout</i>	The degassing of a vacuum system by heating during the pumping process.
<i>bar</i>	Unit of pressure measurement. There are 1.010 bar in one standard atmosphere. One bar equals 1×10^6 dynes per square centimeter.
<i>base pressure</i>	That pressure which is typically reached with your system when it is clean, empty, and dry.
<i>bell jar</i>	A container open at the bottom and closed at the top which is used as a vacuum chamber or test vessel. Also called a work chamber.
<i>bellows-sealed valve</i>	A valve type in which the stem seal is accomplished by means of a flexible bellows, one end of which is attached to the sealing disk, the other end to either the bonnet or the body.
<i>blower pump</i>	A type of vacuum pump which functions from 10 Torr to 0.0001 Torr. Also called a booster or Roots pump.
<i>body</i>	That part of a valve which contains the external openings for entrance and exit of the controlled fluid.
<i>bomb test</i>	A form of leak test in which enclosures are immersed in a fluid. The fluid is then pressurized to drive it through possible leak passages and thus into the internal cavities. The enclosures are then placed in a leak detector to detect the escaping fluid.
<i>bonnet</i>	In general, that part of the valve through which the stem enters the valve, and which is rigidly attached to the valve body.
<i>bourdon gauge</i>	A roughing gauge that responds to the physical forces that a gas exerts on a surface.

APPENDIX - GLOSSARY

Boyle's Law	The gas law that states $P_1V_1 = P_2V_2$, or original pressure times original volume equals new pressure times new volume. This equation predicts new pressure or new volume whenever the other is changed by any amount (providing that the temperature is unchanged).
calibrated leak	An external reference standard that permits calibration of a helium leak detector.
capacitance manometer	A vacuum gauge which senses pressure by the change in capacitance between a diaphragm and an electrode.
Charles' Law	The gas law that describes what happens to the volume of gas as the temperature is changed. As a gas is cooled, its volume gets smaller. As a gas is heated, its volume increases (at constant pressure).
chemisorption	The binding of a gas on or in a solid by chemical action. (<i>See gettering.</i>)
closed-loop refrigeration system	A refrigeration system in which the coolant is recycled continuously.
cold cap	A component mounted on top of the jet assembly in a diffusion pump. This cap helps to keep pump fluid vapor out of the work chamber.
cold cathode discharge	A visible glow caused by the recombination of electrons and ions. The color is characteristic of the gas species present.
cold cathode gauge	<i>See ionization gauge.</i>
cold trap	<i>See cryotrap.</i>
condensation	The process of a gas turning back into a liquid.
conductance	A term used to indicate the speed with which atoms and molecules can flow through a particular region such as an orifice or pipe.
conductance limited	The inability to make use of the rated speed of a pump due to the use of an opening or pipe smaller than the inlet diameter of the pump.
conduction	The transfer of energy (heat, light, etc.) by direct contact. In the case of gaseous conduction, the transfer of energy by molecules directly contacting surfaces and other molecules.
convection	The transfer of heat from one place to another by the circulation of currents of heated gas or other fluid.
critical forepressure	<i>See maximum tolerable foreline pressure.</i>
crossover	The pressure at which a vacuum chamber is changed from being pumped by a roughing pump to being pumped by a high vacuum pump.
cryocondensation	The pumping of gases that are condensed at cold temperatures. For example, water vapor on a liquid nitrogen trap at -196 °C.
cryosorption	The pumping of gases that are not readily condensed (or pumped) at cold temperatures, by the process of sticking onto a cold surface.
cryotrap	A device usually placed before the inlet of a high vacuum pump to "trap" or freeze out gases such as pump oil vapor and water vapor. Cryotrap commonly use liquid nitrogen as the coolant. Also called cold trap or liquid nitrogen trap.

degassing	The removal of gas from a material, usually by application of heat under high vacuum. (<i>See bakeout.</i>)
desorption	<i>See outgassing.</i>
diffusion	(1) The flow of one substance through another by random molecular motion. (2) The process by which molecules intermingle as a result of their thermal motion.
diffusion pump	A vapor pump having boiler pressures of a few Torr and capable of pumping gas continuously at intake pressures not exceeding about 2 mTorr and discharge pressures (forepressures) not exceeding about 500 mTorr. The term diffusion should be applied only to pumps in which the pumping action of each vapor jet occurs as follows: The gas molecules diffuse through the low-density scattered vapor into the denser, forward-moving core of freely expanding vapor jet. Most of the gas molecules are then driven at an acute angle toward the wall and on into the fore vacuum.
dynamic seal	A seal that moves. (<i>See static seal.</i>)
electron	A negatively charged particle. (<i>See atom.</i>)
evaporation	The process that happens when a liquid or solid becomes a gas.
feedthrough	A device used to allow some sort of utility service to go from the outside world to the inside of a vacuum system while maintaining the integrity of the vacuum; for example, an electrical feedthrough.
foreline	The section of a pump through which the gases leave. The exhaust line of a pump.
foreline valve	A vacuum valve placed in the foreline to permit isolation of the pump from its forepump.
forepump	The pump which is used to exhaust another pump, which is incapable of discharging gases at atmospheric pressure. Also called the backing pump.
fractionation	A process that helps to purify the condensed fluid in a diffusion pump. This process removes contaminants produced by decomposition of pump fluid.
gas	A state of matter where the individual particles are free to move in any direction and tend to expand uniformly to the confines of a container.
gas ballast	A method used with any oil-sealed rotary pump which allows a quantity of air to be admitted during the compression cycle to prevent condensation of water vapor. The amount of air admitted is regulated by the gas ballast valve. The use of gas ballast raises the ultimate pressure of the pump.
gas density	The number of molecules per unit of volume.
gas load	The amount of gas being removed from a vacuum chamber by the vacuum pumps. Typically measured in Torr-liters per second, cubic feet per minute, or cubic meters per hour.
gauge pressure	<i>See pressure, gauge.</i>
Gay-Lussac's Law	The gas law that states that if the temperature of a volume of gas at 0 °C is changed by 1 °C, the volume will change (plus or minus, as appropriate) by 1/273 of its original value.

APPENDIX - GLOSSARY

general gas law	The gas law that covers pressure, volume, and temperature in one single equation, or $P_1V_1T_2 = P_2V_2T_1$.
gettering	A method of pumping gases through chemical reaction of a material with gas molecules. The material usually used is an active element such as titanium. (<i>See chemisorption.</i>)
helium mass spectrometer	
leak detector (HMSLD)	See mass spectrometer leak detector.
high vacuum	Pressure which ranges from about 10^{-4} Torr (0.0001 Torr) to approximately 10^{-8} Torr (0.00000001 Torr).
high vacuum pump	A vacuum pump which will function in the high vacuum range. Common examples are the diffusion pump and the mechanical cryopump.
high vacuum valve	A large diameter valve usually placed between the vacuum chamber and the vacuum pumps. It is used to isolate the vacuum chamber from the pumps when it is necessary to work on something in the chamber. Also called hi-vac valve, gate valve, or trap valve.
implosion	In vacuum work, the inward collapse of the walls of a vacuum system, caused by external pressure.
inside-out leak detection technique	A method of leak detection whereby the tracer gas is placed under pressure inside the container to be leak-checked. A detector probe attached to a leak detector is used to locate leaks.
ion	A charged particle consisting of an atom or molecule which has an excess of positive or negative charges. Typically produced by knocking an electron(s) out of an atom or molecule to produce a net positive charge.
ionization	The process of creating ions. (<i>See ion.</i>)
ionization gauge	<p>A vacuum gauge that has a means of ionizing the gas molecules, electrodes to enable the collection of the ions formed, and a means of indicating the amount of the collected ion current. Various types of ionization gauges are identified according to the method of producing the ionization. The common types are:</p> <ol style="list-style-type: none">1. hot cathode ionization gauge The ions are produced by collisions of gas molecules with electrons emitted from a hot filament (or cathode) and accelerated by an electric field. Also called hot-filament ionization gauge, or simply ion gauge.2. cold cathode ionization gauge The ions are produced by a cold cathode discharge, usually in the presence of a magnetic field, which lengthens the path of the electrons.
ion pump	An electrical device for pumping gas. The ion pump includes a means for ionizing the gas with a system of electrodes at suitable potentials, and also a magnetic field. The ions formed move toward a cathode or a surface on which they are reflected, buried, or cause sputtering of cathode material.
jet assembly	A nozzle assembly that directs oil vapors in a diffusion pump.

leak	Leaks may be of three different types: (1) a real leak, which is a crack or hole allowing gases to pass through; (2) a virtual leak, which is caused by outgassing of some volatile material inside a vacuum system or trapped volume; and (3) a permeation leak, which consists of atomic-scale holes throughout the material of construction: for example, O-rings are quite permeable.
leak detector	A device for detecting, locating and/or measuring leakage.
leak rate	Mass flow through an orifice per unit time. Vacuum system leakage rates are typically measured in atm-cc per second or Torr-liters per second.
liquid nitrogen trap	See <i>cryotrap</i> .
mass	A fundamental characteristic of matter which is most closely related to the unit of weight.
mass spectrometer (MS)	An instrument that is capable of separating ionized molecules of different mass/charge ratios and measuring the respective ion currents. The mass spectrometer may be used as a vacuum gauge that measures the partial pressure of a specified gas, as a leak detector sensitive to a particular tracer gas, or as an analytical instrument to determine the percentage composition of a gas mixture.
mass spectrometer leak detector	A mass spectrometer adjusted to respond only to the tracer gas. Helium is commonly used as the tracer gas, and thus the instrument is normally referred to as a helium leak detector.
maximum tolerable foreline pressure	A measure of the ability of the diffusion pump to pump gases against a certain discharge pressure. Also called critical forepressure.
mean free path	The average distance between molecular collisions. Of importance for vacuum systems where one is interested in getting some particular type of particle from a source to a surface. For example, ion implanters, coaters, or television tubes.
micron	Pressure unit equivalent to 1 mTorr.
millibar	Unit of pressure measurement, equal to 1/1000 bar.
millimeter of mercury	See <i>Torr</i> .
milliTorr	Unit of pressure measurement, equal to 1/1000 Torr.
mole	The number of particles in equal volumes of gases under the same conditions of temperature and pressure. One mole of any gas has 6.023×10^{23} particles.
molecular density	The number of molecules in a unit of volume such as a cubic centimeter. There are approximately 3×10^{19} molecules per cc at one standard atmosphere.
molecular flow	The type of flow which occurs when gas molecules are spread far apart. There are few collisions so that the molecules tend to act independently of other molecules that may be present. The molecular directions are completely random.
molecular sieve	A very porous material used to contain the pumped gases in sorption pumps. May also be used in a foreline trap to contain oil molecules.

APPENDIX - GLOSSARY

<i>molecular sieve trap</i>	A device used to collect oil vapors backstreaming from oil-sealed mechanical pumps.
<i>molecular weight</i>	A way of classifying molecules according to their weight, or mass. Molecular weight or mass is the sum of the individual atomic weights that make up the molecule.
<i>molecule</i>	One atom, or two or more atoms joined together and having definite chemical and physical characteristics.
<i>neutron</i>	A particle located in the nucleus of an atom which has no electrical charge but does have mass. (<i>See atom.</i>)
<i>nucleus</i>	The dense center portion of an atom containing protons and neutrons. (<i>See atom.</i>)
<i>open-loop refrigeration system</i>	A refrigeration system in which the coolant vents to atmosphere.
<i>outgassing</i>	The process in which a gas particle leaves a surface and moves into the volume of a vacuum chamber. This adds to the gas load and may or may not be desirable. In extreme cases, it prevents “pumping down” a vacuum system to the specified pressure. The system is then said to be “hung up,” or outgassing. Also called desorption or virtual leak.
<i>outside-in leak detection technique</i>	A leak detection technique where the leak detector senses a tracer gas that passes from the outside of the container to the inside of the container. May be used to determine the size and/or the location of a leak.
<i>partial pressure</i>	<i>See pressure, partial.</i>
<i>pascal</i>	Unit of pressure measurement. There are 101,325 pascals in one standard atmosphere. A pascal equals one newton per square meter.
<i>permeation leak</i>	Molecular-scale holes through a material of construction. (<i>See leak.</i>)
<i>Pirani gauge</i>	A vacuum gauge used to measure pressure in the rough vacuum range.
<i>powers of ten</i>	A convenient way of describing very large and very small numbers. A number is written as some value from 1 and up to 10 (but not including 10). Then, it is multiplied by either a positive or negative power of ten. Also called exponential notation or scientific notation.
<i>pressure</i>	Force per unit area. The force is created when atoms, molecules, or “particles” strike the walls of their container. Common pressure units for vacuum work are Torr, pounds per square inch relative (psig), inches of mercury, millimeters of mercury, bar, millibar, and pascal.
<i>pressure, absolute</i>	Pressure above zero pressure (corresponding to totally empty space) as distinguished from “gauge” pressure. In vacuum technology, pressure is always measured from zero pressure, not atmospheric pressure, and therefore the term absolute pressure is not required.
<i>pressure, gauge</i>	The difference between absolute pressure and atmospheric pressure. The most common unit is probably psig.
<i>pressure measurement</i>	A measurement of the pressure (the number and intensity of particle impacts) on a given unit of area. There are several different scales for pressure measurement: for example, Torr, milliTorr, bar, millibar, and pascal. These scales may be used as absolute or relative scales.
<i>pressure, partial</i>	A measurement of the pressure of one particular gas in a mixture of gases. For example, the partial pressure of oxygen in air is about 160 Torr.

<i>pressure, relative</i>	<i>See pressure, gauge.</i>
<i>pressure, total</i>	The sum of all of the partial pressures of every gaseous species. The force exerted by all the gas molecules in any mixture of gases. We commonly assume that a pressure gauge reads total pressure.
<i>pressure, vapor</i>	The pressure exerted by molecules after they have escaped from a liquid or solid and formed a vapor (gas). One tries, in general, to put substances of low vapor pressure into a vacuum system so as to decrease the gas load on the vacuum pumps.
<i>probe</i>	A tube having a fine opening at one end, used for directing or collecting a stream of tracer gas.
<i>probe test</i>	A leak test in which the tracer gas is applied by means of a probe so that the area covered by a tracer gas allows the tracer gas to enter and locate the leak.
<i>proton</i>	A positively charged particle. (<i>See atom.</i>)
<i>psia</i>	Pounds per square inch absolute, a unit of pressure measurement. There are 14.69 psia in one standard atmosphere.
<i>psig</i>	Pounds per square inch gauge, a unit of pressure measurement. Gauge pressure is the difference between absolute pressure and atmospheric pressure. One standard atmosphere equals 0 psig.
<i>pump-down curve</i>	A graphic plot of pressure versus time as a vacuum system is being pumped. Usually plotted on graph paper. Can be used to distinguish real leaks from virtual leaks.
<i>pumping speed</i>	A measure of the ability of a vacuum pump to remove gases. It is typically measured in liters per second, cubic feet per minute, or cubic meters per hour.
<i>radiation</i>	Heat transfer by energy from infrared light. Radiated heat is the only way to transfer heat inside of a vacuum system at high vacuum.
<i>rate of rise</i>	The rate of pressure increase versus time when a vacuum system is suddenly isolated from the pump by a valve. The volume and temperature of the system are held constant during the rate-of-rise measurement.
<i>rate-of-rise test</i>	A method of determining whether a leak is present in a system, or of obtaining an estimate of the magnitude of a leak, by observing the rate of rise of pressure in the evacuated system when the system is isolated from the pump. This method also can determine if leakage is real or virtual.
<i>real leak</i>	A crack or hole that allows gases to pass through in both directions. (<i>See leak.</i>)
<i>regeneration</i>	Some vacuum pumps and traps fill up from usage (containment pumps) and must be emptied periodically. The process of emptying the pump is called regeneration.
<i>residual gas analyser</i>	A gauge that measures partial pressure.
<i>Roots blower</i>	<i>See blower pump.</i>
<i>roughing</i>	The initial evacuation of a vacuum system.
<i>rough pump</i>	A vacuum pump which will function in the rough vacuum range. A roughing pump is often used to "rough" a vacuum chamber. Typical examples of rough pumps are the mechanical pump and the sorption pump.

APPENDIX - GLOSSARY

<i>rough vacuum</i>	Pressure which ranges from just below atmospheric pressure to about 10^{-3} Torr (0.001 Torr).
<i>sniffer probe</i>	<i>See probe. (More correctly called a detector probe.)</i>
<i>sputtering</i>	The release of one or more molecules from a cathode surface when that surface is struck by a high-energy ion.
<i>standard atmosphere</i>	At 45° N latitude, at sea level, and 0 °C, the average pressure exerted on the earth's surface. This average pressure is 14.69 pounds per square inch (absolute), or 14.69 psia.
<i>standard cubic centimeter</i>	The quantity of gas in a volume of 1 cc at standard temperature and pressure (0 °C, 760 Torr).
<i>static seal</i>	A seal that does not move. <i>(See dynamic seal.)</i>
<i>sublimation</i>	The process in which a substance can go directly from the solid state to the vapor state, without passing through a liquid state.
<i>sublimes</i>	Changes directly from a solid to a vapor state.
<i>TC gauge</i>	<i>See thermocouple gauge.</i>
<i>temperature</i>	A qualitative measurement of energy. The hotter something is, the more energy it contains, thus its temperature is higher.
<i>thermal expansion rate</i>	Materials change in size as their temperature changes. This size-to-temperature relationship of the material is called its thermal expansion rate.
<i>thermocouple gauge</i>	A vacuum gauge used to measure pressure in the rough vacuum range.
<i>throughput</i>	Pumping speed times the pressure. It is a term used to measure the quantity of gas per unit of time flowing through a vacuum system or through a component of that system, such as a pump. Typical units are Torr-liters per second. It is a unit of power: 5.70 Torr-liters/sec = 1 watt
<i>Torr</i>	Unit of pressure measurement, equal to the force per unit area exerted by a column of mercury one millimeter high. There are 760 Torr in one standard atmosphere.
<i>tracer gas</i>	A gas which, passing through a leak, can be detected by a specific leak detector and thus reveal the presence of a leak.
<i>transfer pressure</i>	<i>See crossover pressure.</i>
<i>transition range</i>	A range of pressure that cannot be correctly defined as either a viscous flow condition or molecular flow condition.
<i>trap</i>	A device which will hold selected molecules and not let them pass. Two common types are the molecular sieve trap and the liquid nitrogen trap.
<i>tubulation</i>	A pipe or hose used in a vacuum system.
<i>ultimate pressure</i>	The lowest pressure a vacuum pump or vacuum system can reach when clean and empty. Is dependent upon the particular gas species being pumped.
<i>ultrahigh vacuum</i>	Pressure which ranges from about 10^{-8} Torr (0.00000001 Torr) to less than 10^{-14} Torr.

<i>ultrahigh vacuum pump</i>	A vacuum pump which will function in the ultrahigh vacuum range. Typical examples are the ion pump and the TSP (titanium sublimation pump).
<i>useful operating range</i>	The pressure range of a vacuum pump between the higher pressure limit where it will begin pumping and the base (or ultimate) pressure, which is the pump's lower operating limit.
<i>vacuum</i>	Any pressure lower than atmospheric pressure.
<i>vacuum pump</i>	A type of pump which is capable of removing the gases in an enclosed volume such as a vacuum chamber. Vacuum pumps are typically divided into three broad categories: (1) roughing pumps, (2) high vacuum pumps, and (3) ultrahigh vacuum pumps.
<i>vapor</i>	The gas produced as a result of evaporation.
<i>vapor pressure</i>	<i>See pressure, vapor.</i>
<i>vent valve</i>	A valve used for letting atmospheric air or other gas into a vacuum system. Also called a BTA or back-to-air valve.
<i>virtual leak</i>	An apparent leak that is caused by release of gas from a trapped volume or outgassing of some volatile material or trapped gas inside a vacuum system. (<i>See leak.</i>)
<i>viscous flow</i>	The type of flow which occurs when gas molecules are packed closely together and collide with each other quite frequently.
<i>work chamber</i>	A contained volume from which some of the air and other gases have been removed. The work chamber separates the vacuum from the outside world. The portion of a vacuum system where the process is performed. (<i>See bell jar.</i>)